

UNBRANDED - Double

Assembly Instructions

Before you begin...

1. Please check in your desired room of use.
2. Unpack all boxes and lay out each component on the floor.
3. Check your product for any damage that may be immediately obvious. If damage is identified, please contact your retailer.
4. Please read through these instructions thoroughly to ensure you have constructed your bed correctly.

For Care and Maintenance of your bed...

- Always assemble in your desired room of use.
- Always check all screw and fixings periodically to ensure they are still secure.
- Do not push or pull this bed as it will cause damage.
- Always lift this bed with a second person to prevent damage or injury.
- Keep any sharp objects away from this bed frame.

For your Health and Safety...

- Please don't not jump on this bed.
- Do not use this bed if you find missing, damaged or worn parts. Please contact your retailer.
- Please do not use this bed until you have fully secure all fixings.
- Please keep all small components away from children.
- Please ensure this bed is on an even, level surface.

Also...

If your desired room of choice has a non-carpeted surface ensure please that you use some form of anti-slip protection and **do not** place directly on the wooden floor. This will prevent the bed from moving and therefore collapsing which will void your guarantee...

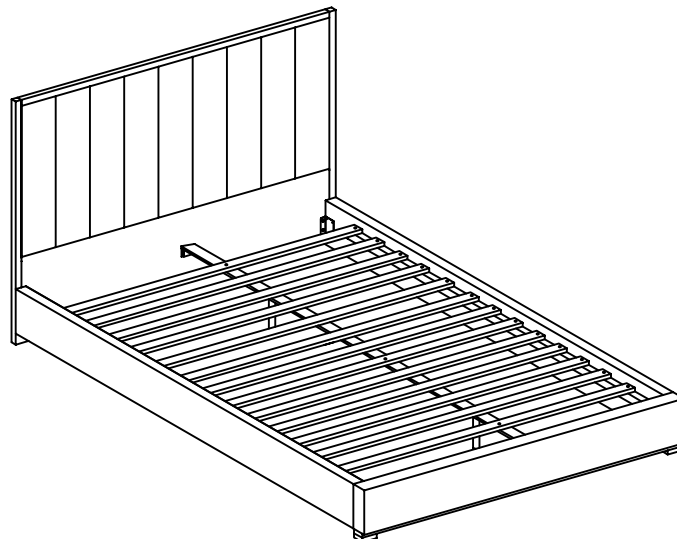



Box 1

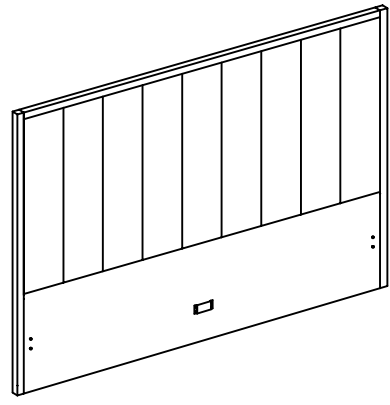

1.Headboard (x1)

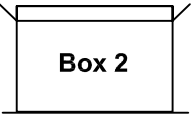

Box 2

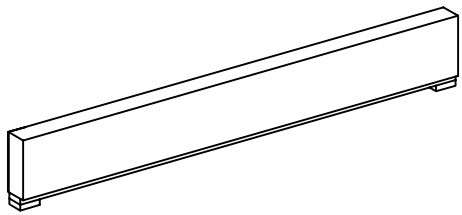

2.Footboard (x1)

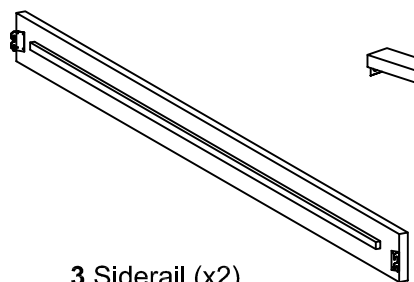

3.Siderail (x2)

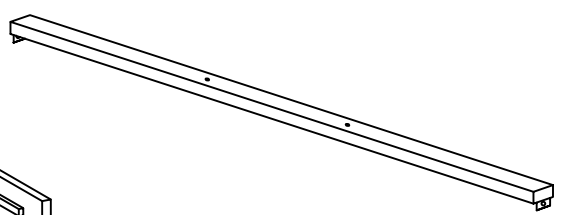

4.Centre Rail (x1)

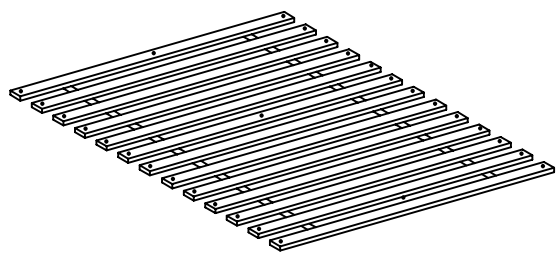

5.Slats (x1)

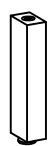

6.Support Legs (x2)

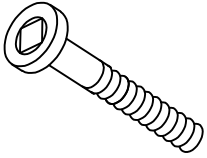

A.M6 x 40 mm JCBC (x2)

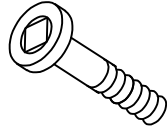

B.M6 x 30 mm JCBC (x8)



C.Allen Key M4 x 65 mm (x1)

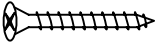

D.M4 x 25 mm CSK (x2)

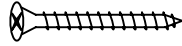

E.M4 x 32 mm CSK (x29)

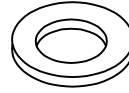

F. Flat Washer (x8)

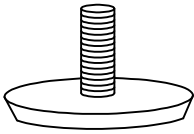

G.Adjustable Foot (x2)

***You will need a screwdriver (not provided)**

Step 1

Unpack all components from the boxes and check you are not missing anything. Please check these against the list on page 3 & 4. Should you identify any missing components, please contact the retailer you purchased the bed from.

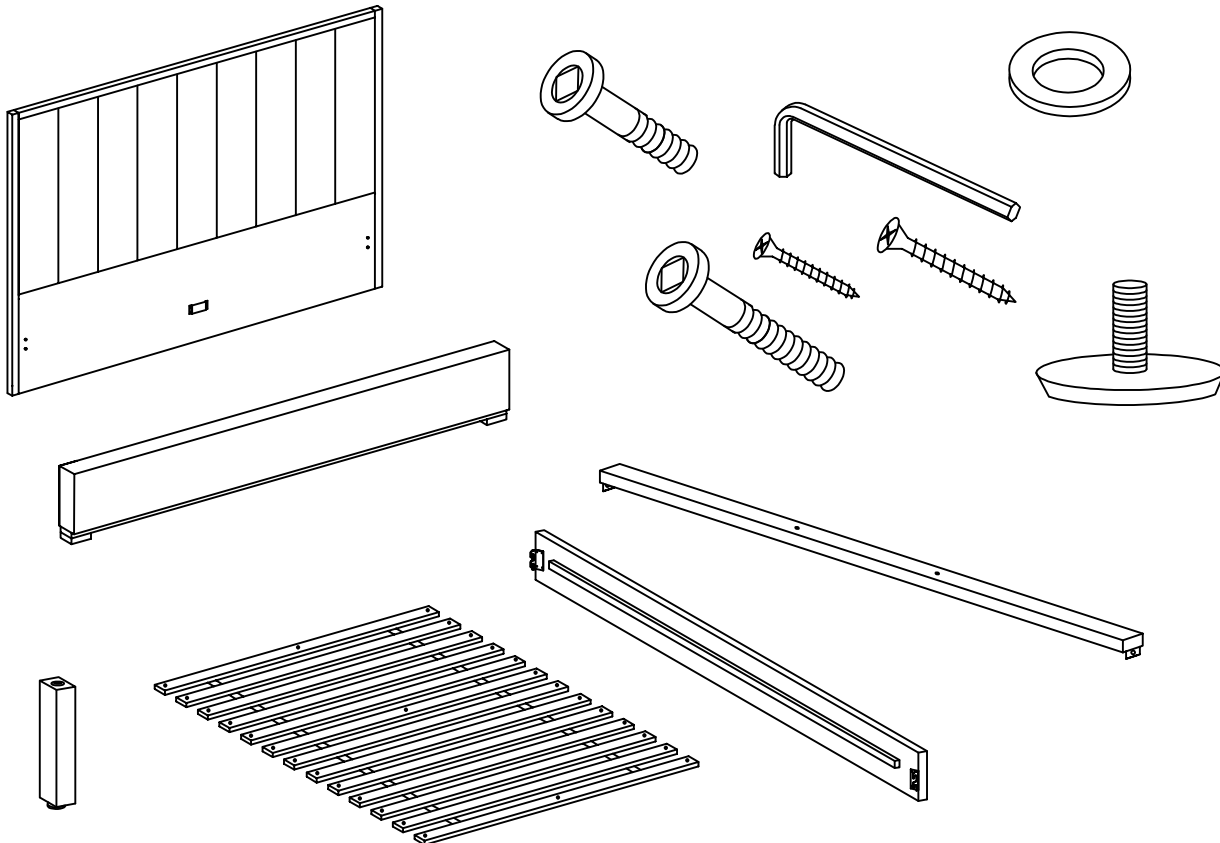

Step 2

Attach Side Rail (3) x2 to Footboard (2) and Headboard (1) using JCBC M6 x 30 (B) and Flat Washer (F).

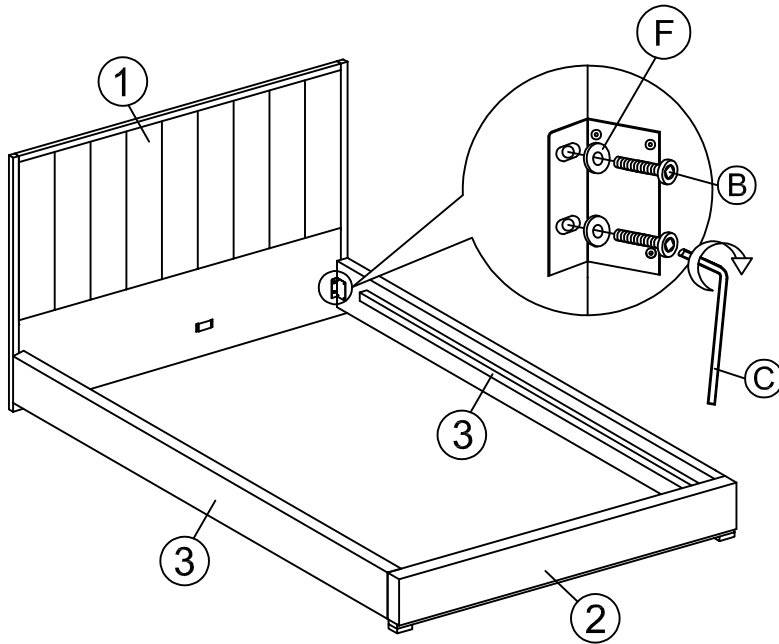

Step 3

Attach the 2x support legs (6) to 1x centre rail (4) using 2x M6x40mm JCBC (A) and 1x M4 Allen Key (C). Then screw 2x Adjustable Foot (G) to 2x support legs (6).

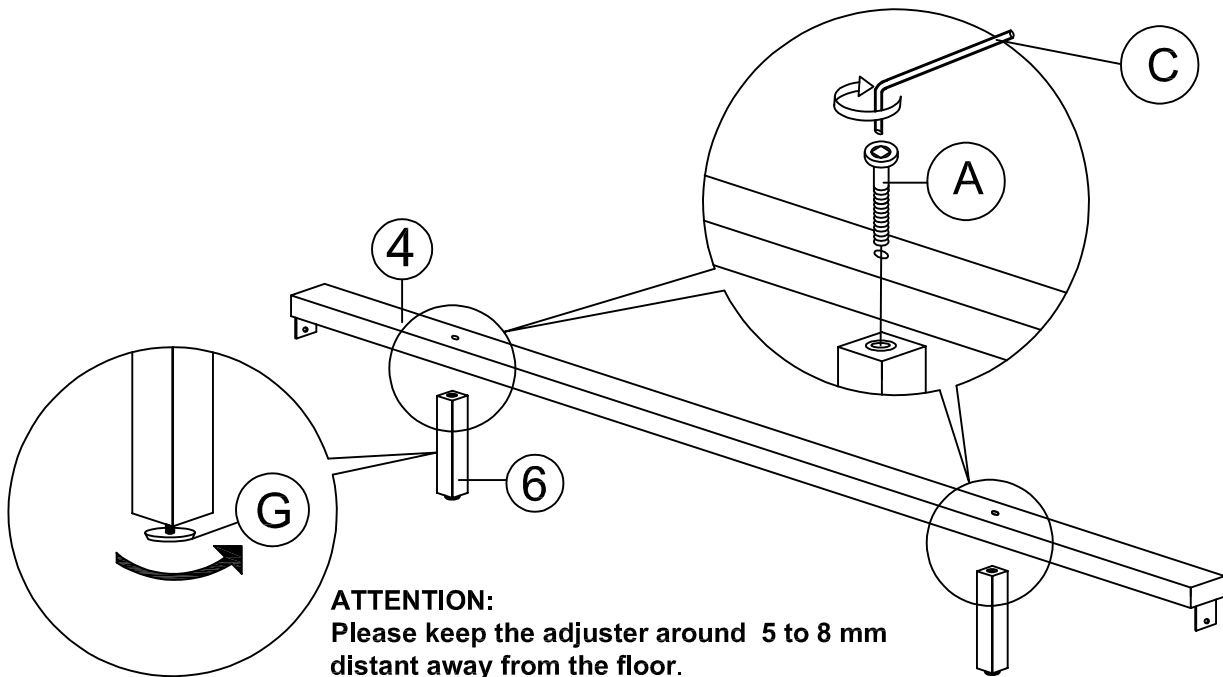

DO NOT use any power tools as this may damage the frame and will invalidate any claim.

Step 4

Firstly, slot the 1x centre rail (4) to the bracket on 1x Headboard (1) and 1x Footboard (2). Then secure using 2x M4x25mm CSK (D) and Screwdriver (Not Provided).

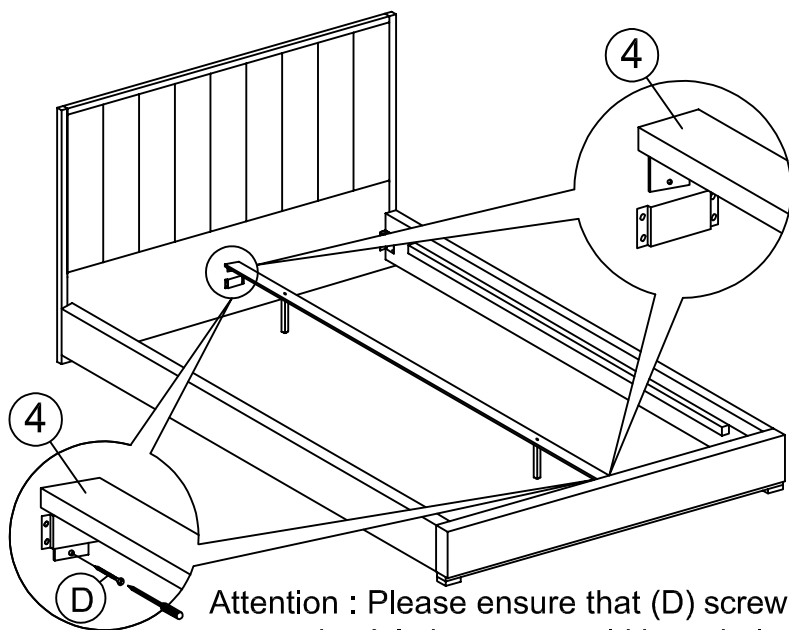

Attention : Please ensure that (D) screw is being attach as per the A.I shown to avoid base being collapse.

Step 5

Lay the slats (5) onto the support wood on 2 x side rail (3) and the 1 x center rail (4). Place slats so the ribbon is underneath. Insert CSK screw (E) into pre-drilled holes in slats and tighten with screwdriver.

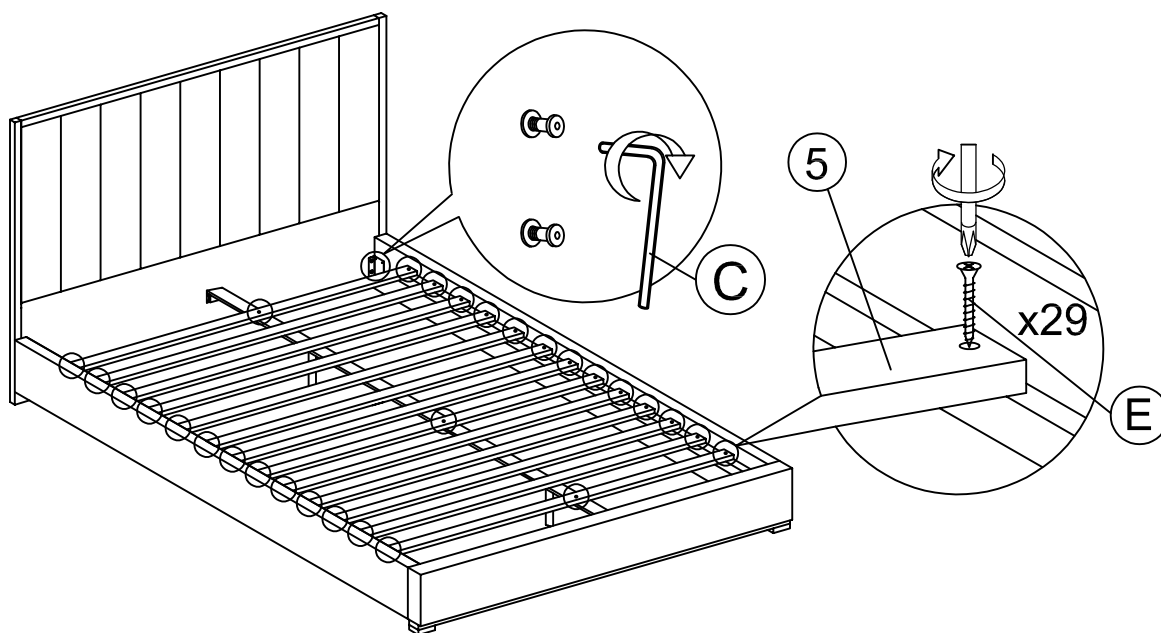

DO NOT use any power tools as this may damage the frame and will invalidate any claim.