



CARE OF YOUR KY410 BED (4' 6 ")

Do not discard any of the packaging until you have checked the product.

Outlined below are General Care Instructions that will help prolong the look and life of your bed by preventing wear and damage.

PLEASE NOTE: The Fabric on this product is Flame Retardant treated and therefore should be Specialist Upholstery cleaned only

CLEAN REGULARLY:

- ✚ Remove dust by pre-brushing with a soft brush
- ✚ Gently Vacuum all areas

SUNLIGHT AND HEAT

- ✚ Direct sunlight or heat can cause fabrics to deteriorate or fade. Protect them by situating your furniture out of the way of prolonged direct sunlight or by drawing curtains and blinds when applicable.
- ✚ Avoid placing furniture too close to fires or radiators.
- ✚ Reduce potential damage by moving items around or changing position so that the same piece or area is not always exposed.

SAFETY WARNINGS

- ✚ Never allow children to jump on the bed.
- ✚ Do not allow domestic pets to climb on the bed chew or claw it; oils and greases from animals will cause deterioration in the appearance of the fabric.
- ✚ Sharp objects such as buckles, toys and jewellery can easily snag on the fabric and produce tears and pulls the fabric.
- ✚ Hot objects such as the heat from cups and mugs can permanently disfigure upholstery.

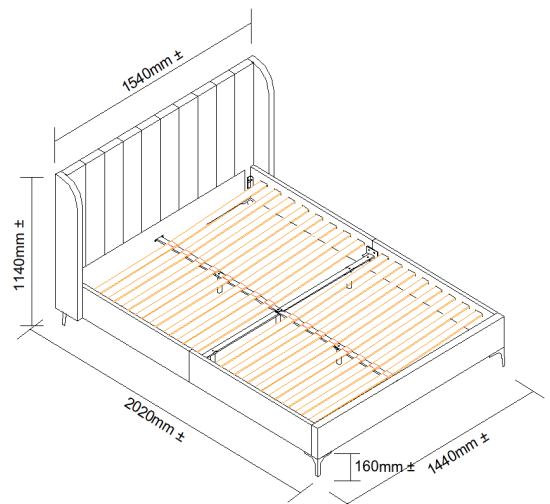

Parts List

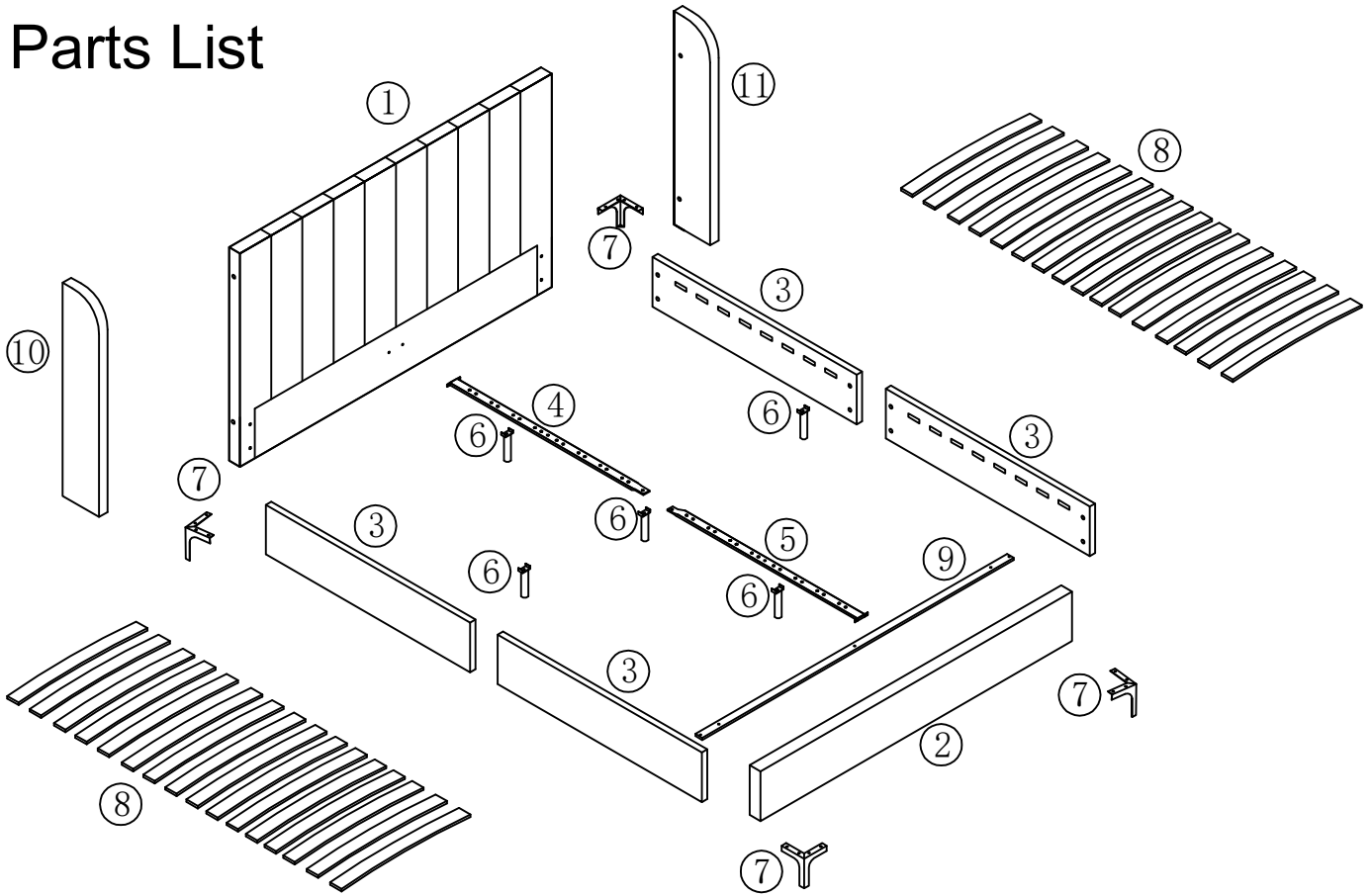

Hardware List

Label	Picture	Description	Qty	Label	Picture	Description	Qty
A		Double Plastic Cap	16	H		Bolt M6x35	1
B		L Bracket Plate	2	I		Bolt M6x25	6
C		Connection	2	J		Bolt M6x20	20
D		Bolt M8x25	8	K		Screw 4x25mm	16
E		Spring Washer	8	L		Connection Plate Left	2
F		Washer M8	16	R		Connection Plate Right	2
G		Nut M6	2	M		Bolt M8x45	4

Tool List

Label	Picture	Description	Qty
T-1		Screw driver (not provided)	1
T-2		Allen key M5	1
T-3		Allen key M4	1
T-4		Spanner	1

Step 1

M  4pcs







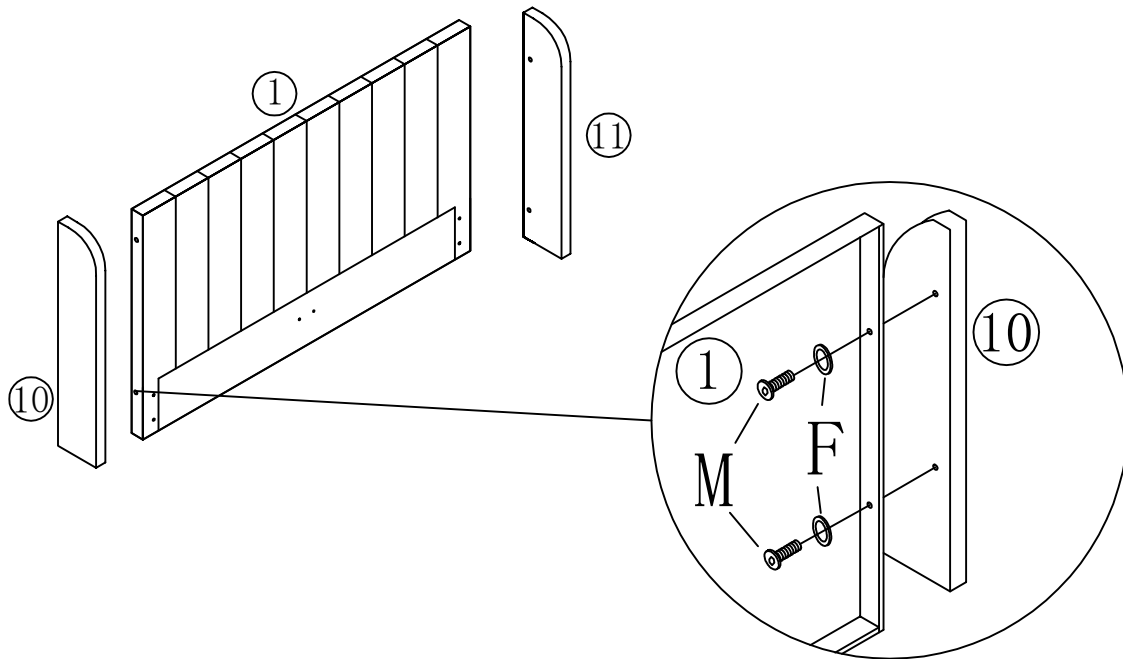

F  4pcs

Bolt M8x45mm

Washer M8



Step 2

L  2pcs	R  2pcs
Connection Plate Left	Connection Plate Right
D  8pcs	E  8pcs
Bolt M8x25	Spring Washer
F  12pcs	J  16pcs
Washer M8	Bolt M6x20
C  2pcs	B  2pcs
Connection L Bracket Plate	L Bracket Plate

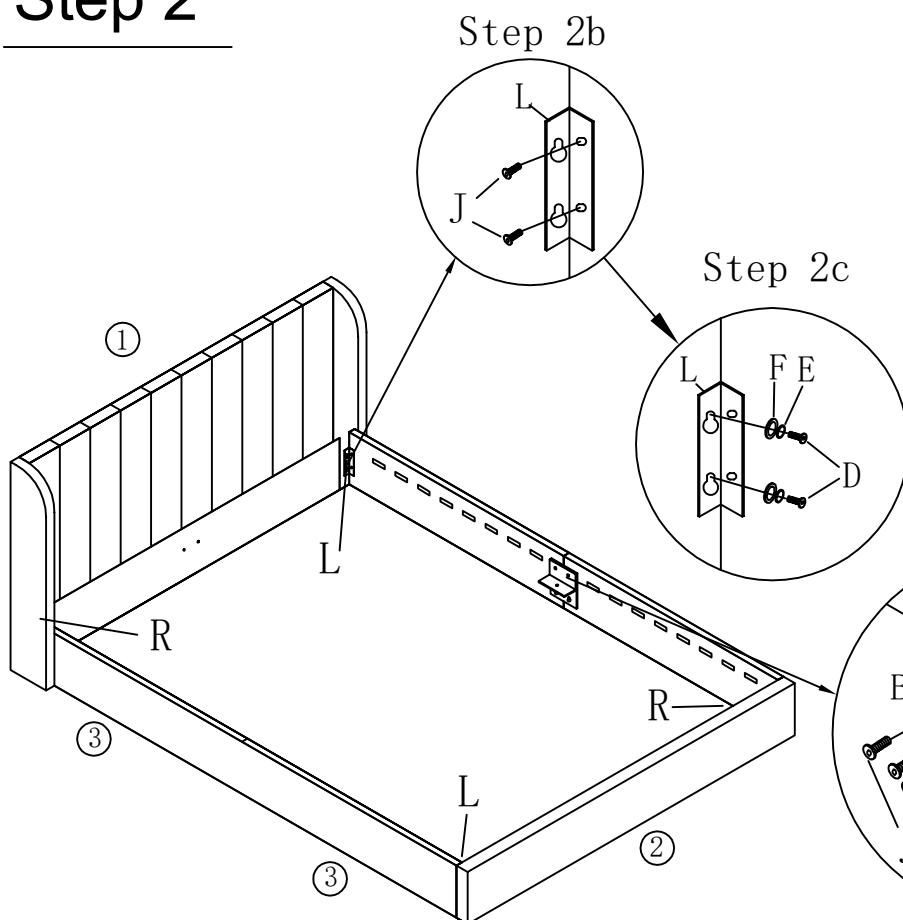



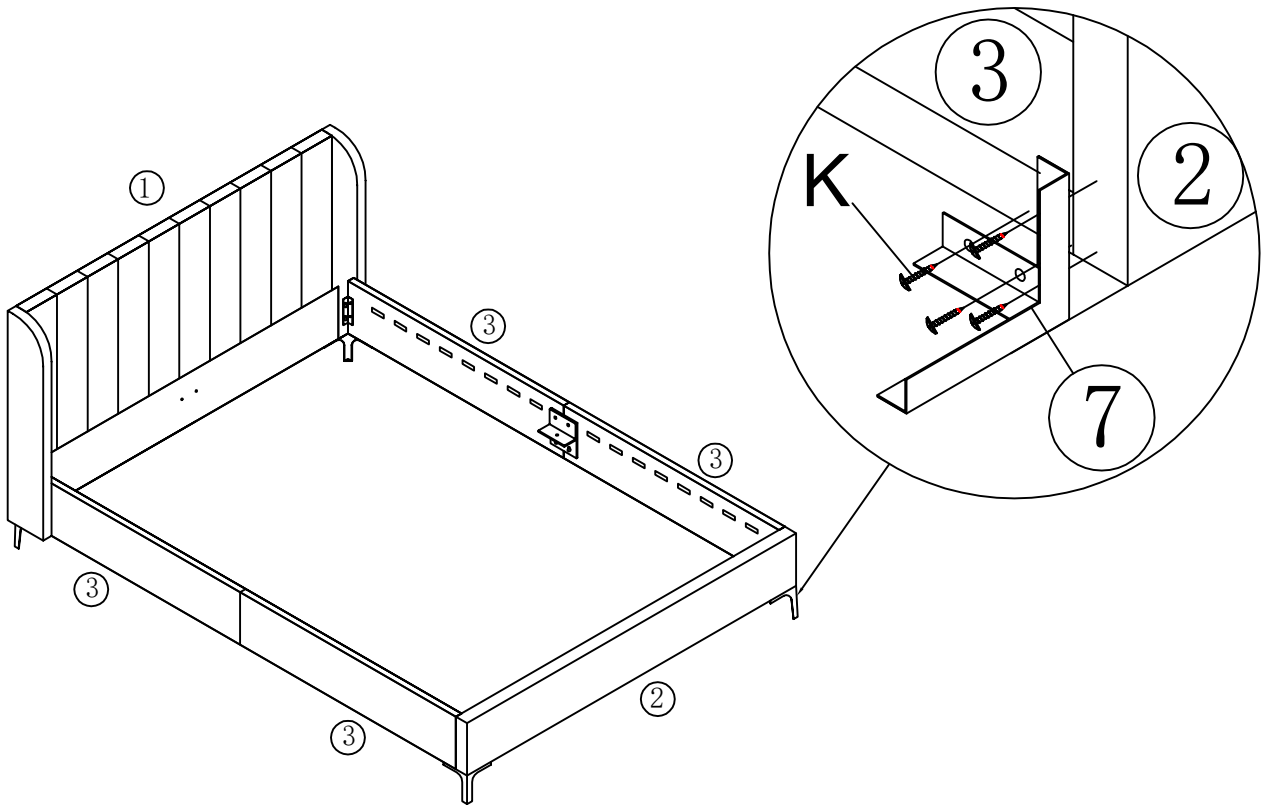

Step 2a

Step 3

K  16pcs
Screw 4x25mm



Step 4

H  1pcs Bolt M6x35	G  2pcs Nut M6	I  6pcs Bolt M6x25
J  4pcs Bolt M6x20		

Step 3c

Step 3d

Step 3a

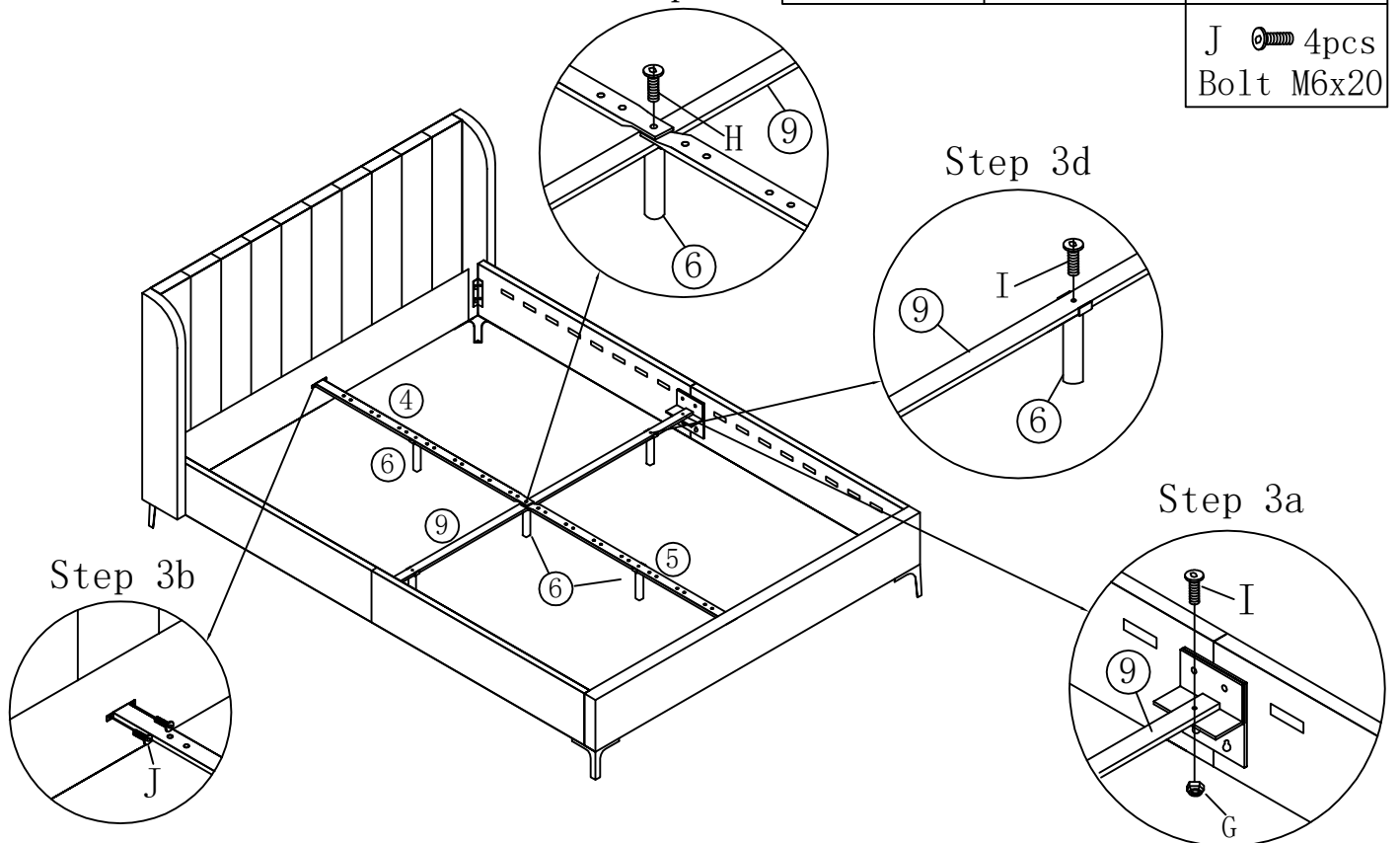

Step 5

A 16pcs
Double
Plastic Cap

