

NEVADA 4 DOOR 2 DRAWER WARDROBE ASSEMBLY INSTRUCTIONS

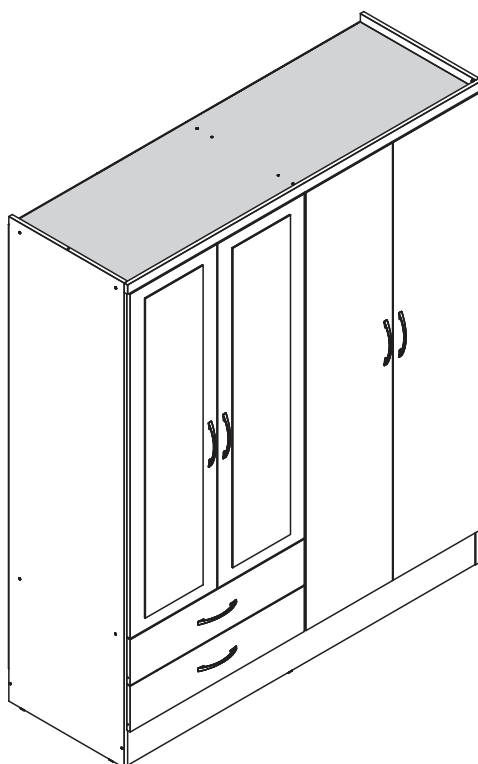

IMPORTANT FOR DOMESTIC USE ONLY

PLEASE READ BEFORE YOU CONTINUE FURTHER

CARE AND MAINTENANCE

After unpacking this product please keep the original packaging in case it needs to be returned for any reason.

- Please ensure all fittings and parts are present before commencing with assembly.
- Never drag or push products as this could cause damage to the joints making it inferior.
- We strongly recommend that you keep children away from your work area.
- We recommend that you lay a blanket or sheet on the floor to avoid damage to both your floor and the product.
- Assemble this product as close to its final position as possible.
- Do not place this product next to a radiator or in direct sunlight.
- Do not drag or push items across your high gloss furniture as this may cause the surface to scratch
- Wood is a natural product and may expand if subjected to damp and may shrink or crack if subjected to heat. Therefore it is recommended that room temperature is maintained, with no sudden temperature fluctuations.
- Make sure any spillage is wiped off immediately.
- Do not place hot or chilled items directly on to the surface, use a place mat or marking will occur.
- For general cleaning use a soft cotton or micro fibre cloth, and do not use detergents of any kind.
- From time to time it may be necessary to tighten fittings, regular inspections should be carried out.
- Do not place on a wet or damp floor as staining may occur to your floor.

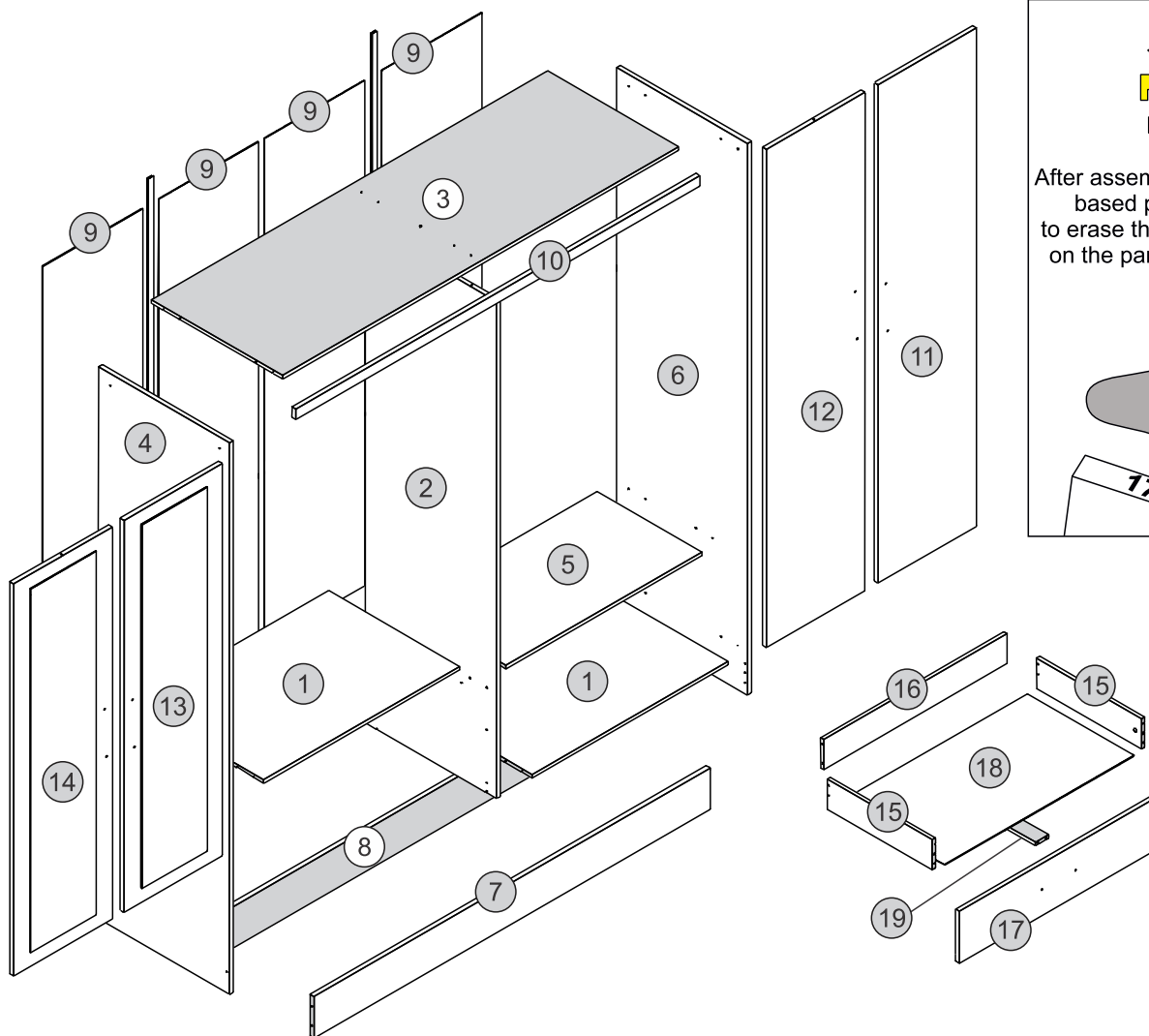

TIP

After assembly use an alcohol based product/cleaner to erase the numbers printed on the parts that are visual.

An illustration showing a hand holding a grey cloth and wiping a surface. The number 17 is visible on the surface being cleaned.









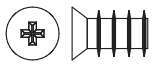
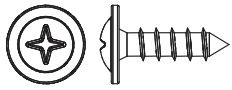
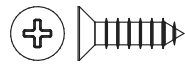
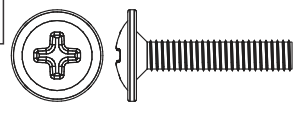
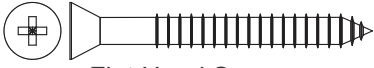
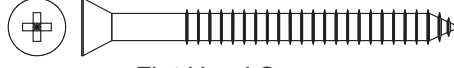
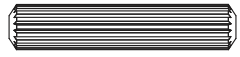

Please Note:
The below parts have all been stamped with the part number to help identify them during assembly.

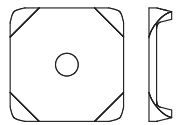
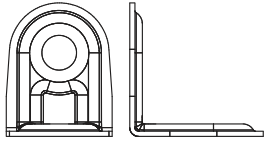
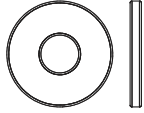
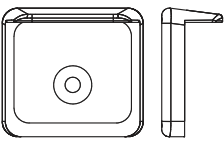
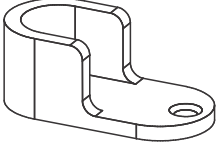
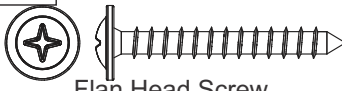
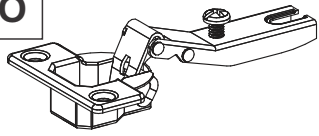
Part Number	Part Description	Quantity	Carton
01	Base Panel	2	1/3
02	Division Panel	1	2/3
03	Top Panel	1	2/3
04	Left Side Panel	1	1/3
05	Shelf	1	1/3
06	Right Side Panel	1	1/3
07	Front Baseboard	1	2/3
08	Back Baseboard	1	2/3
09	Back Panel	4	2/3
10	Frame	1	2/3
11	Right Large Door	1	3/3
12	Left Large Door	1	3/3
13	Right Small Door	1	3/3
14	Left Small Door	1	3/3
15	Drawer Side	4	1/3
16	Drawer Back Panel	2	1/3
17	Drawer Front	2	2/3
18	Drawer Bottom	2	2/3
19	Drawer Bottom Support Bar	2	2/3

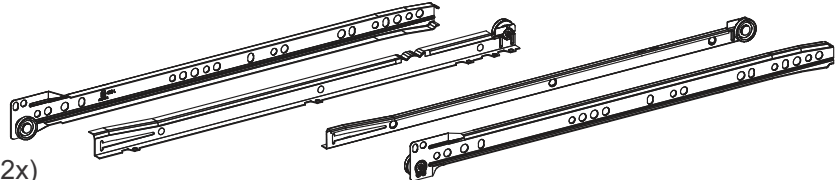
TOOLS REQUIRED

A vertical list of tools required for assembly. From top to bottom: a screwdriver with a crossed-out circle next to it, a mallet, a hammer, a tape measure, and a pencil.

FITTINGS LIST

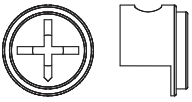
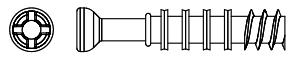
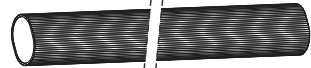
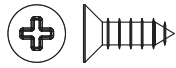
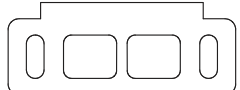
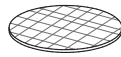
<p>A</p>  <p>Flat Head Screw Ø6,0 x 10mm (8x)</p> <p>+1</p>	<p>B</p>  <p>Flan Head Screw Ø4,0 x 14mm (12x)</p> <p>+2</p>	<p>C</p>  <p>Flat Head Screw Ø4,0 x 14mm (68x)</p> <p>+2</p>	<p>D</p>  <p>Flan Head Screw Ø4,0 x 20mm (12x)</p> <p>+2</p>
<p>E</p>  <p>Flat Head Screw Ø3,5 x 40mm (4x)</p> <p>+1</p>	<p>F</p>  <p>Flat Head Screw Ø4,0 x 50mm (26x)</p> <p>+2</p>		<p>G</p>  <p>+2 Dowel Ø6,0 x 30mm (46x)</p>
<p>H</p>  <p>+2 Nail 10 x 10 (100x)</p>	<p>I</p>  <p>+2 Back Panel Bracket (16x)</p>	<p>J</p>  <p>+2 'L' Metallic Support (10x)</p>	<p>K</p>  <p>+1 Washer (4x)</p>
<p>L</p>  <p>+1 Plastic Foot (6x)</p>	<p>M</p>  <p>Hanging Rail Support (4x)</p>	<p>N</p>  <p>+1 Flan Head Screw Ø3,5 x 30mm (2x)</p>	<p>O</p>  <p>Hinge (12x)</p>
<p>P</p>  <p>Hinge Plate (12x)</p>	<p>Q</p>  <p>Drawer Runners (2x)</p>		
<p>R</p>  <p>Back Panel Strip (2x)</p>	<p>S</p>  <p>Strap (2x)</p>	<p>T</p>  <p>Handle (6x)</p>	<p>U</p>  <p>+2 Hole Plugs (14x)</p>
<p>V</p>  <p>Glue (2x)</p>	<p>W</p>  <p>+1 Cam Nut (4x)</p>	<p>X</p>  <p>+1 Cam Bolt (4x)</p>	<p>Y</p>  <p>Hanging Rail (2x)</p>
<p>Z</p>  <p>+2 Flat Head Screw Ø4,0 x 12mm (28x)</p>	<p>A1</p>  <p>Door Support (4x)</p>	<p>B1</p>  <p>+2 Hole Plugs (6x)</p>	

TIPS FOR FITTINGS CAM-LOCKS

WHEN FITTING CAM NUT, ENSURE STARTING POSITION IS CORRECT BEFORE YOU INSERT CONNECTING CAM BOLT TURN CLOCKWISE UNTIL SECURE

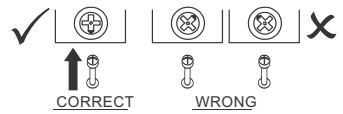

↑ CORRECT ↓ WRONG

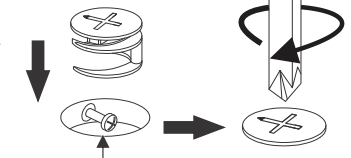

Cam bolt head needs to be in centre

CAMBOLT

Tighten until shoulder in flush with panel. Do not overtighten or undertighten (see example beside)

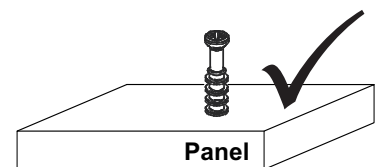
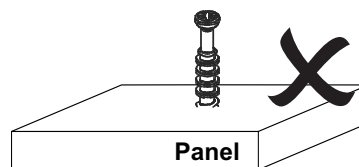

STEP 1

PARTS REQUIRED

4 -LEFT SIDE PANEL x1

HARDWARE REQUIRED

C  08
Ø4,0 x 14mm

H  02

L  02

M  01

P  03

TOOLS REQUIRED

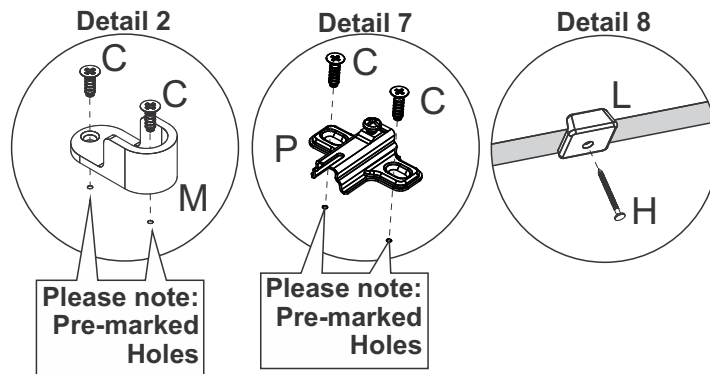
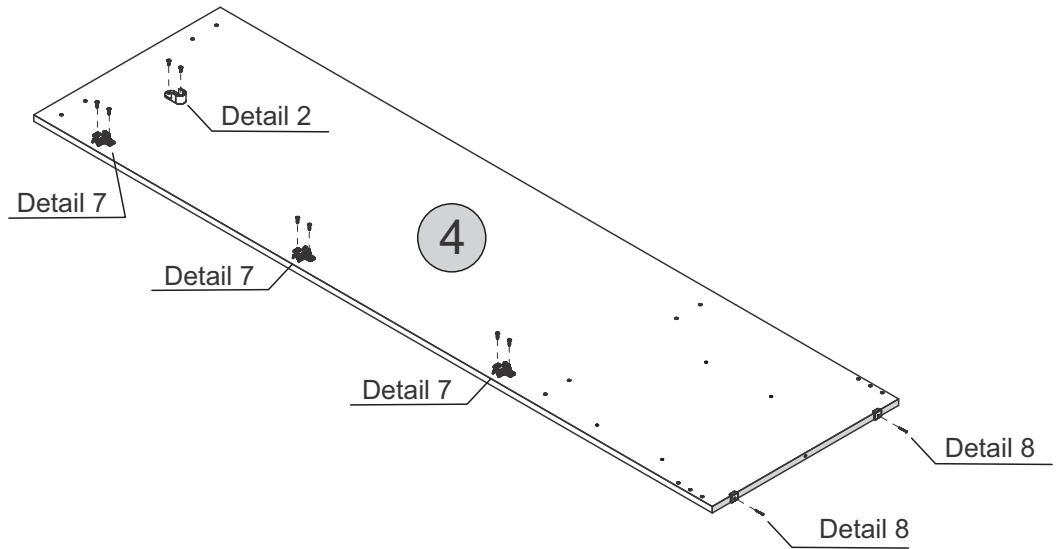
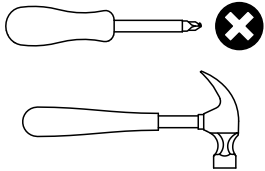

STEP 2

PARTS REQUIRED

4 - LEFT SIDE PANEL x1

HARDWARE REQUIRED

A  04
Ø6,0 x 10mm

Q  02

TOOLS REQUIRED

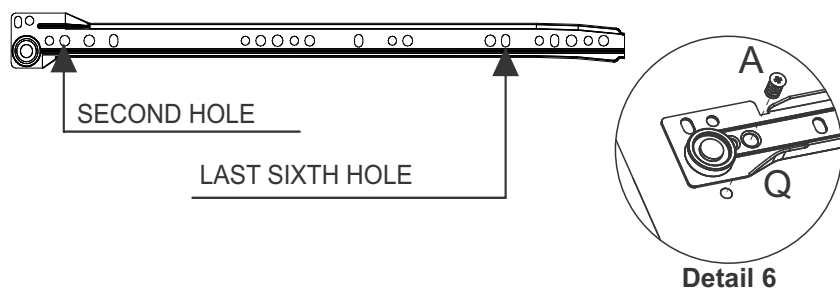
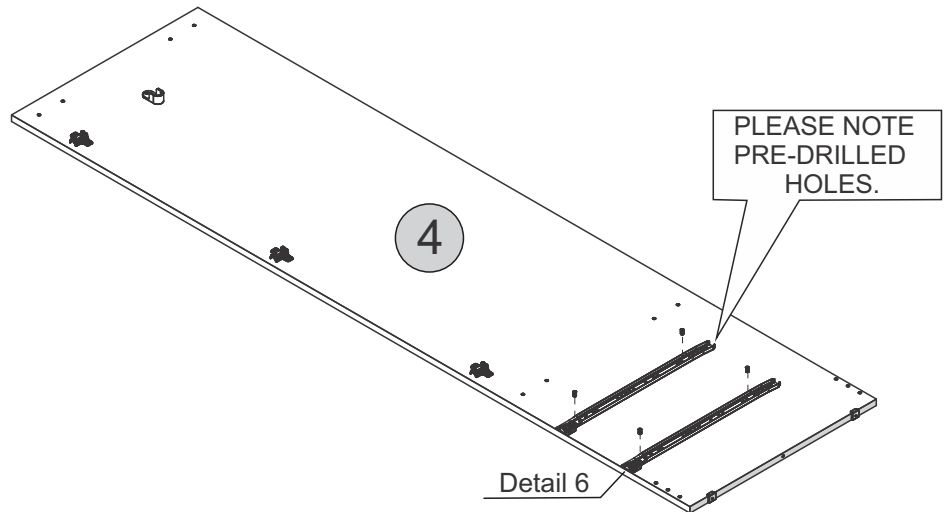
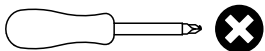



STEP 3

PARTS REQUIRED

2 -DIVISION PANEL x1

HARDWARE REQUIRED

C  08
Ø4,0 x 14mm

G  02
Ø6,0 x 30mm

M  01

P  03

V  01
Glue

TOOLS REQUIRED

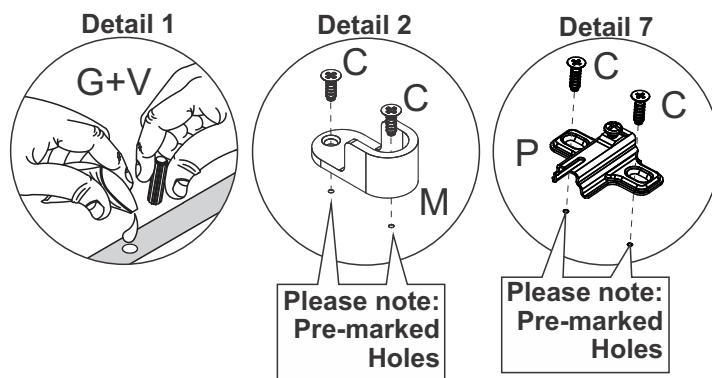
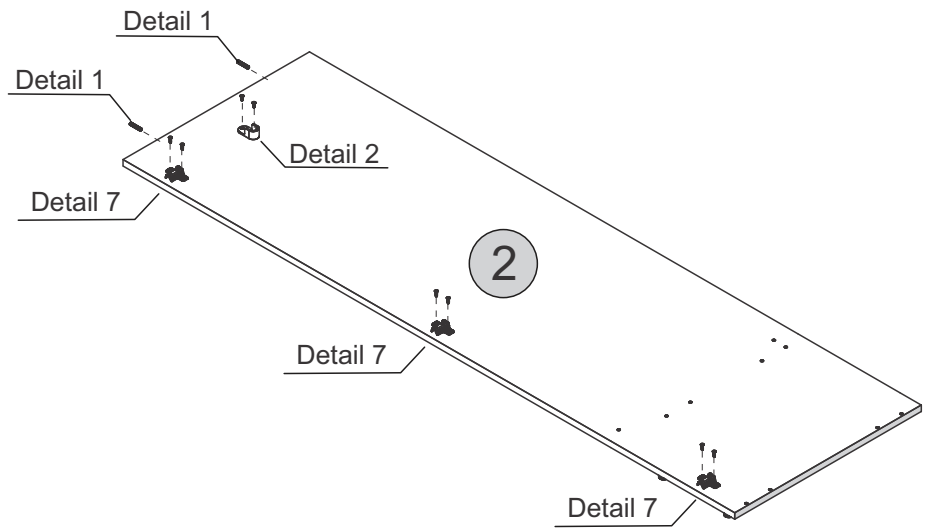
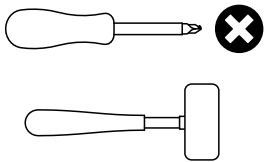

STEP 4

PARTS REQUIRED

2 - DIVISION PANEL x1

HARDWARE REQUIRED

C  08
Ø4,0 x 14mm

M  01

P  03

TOOLS REQUIRED

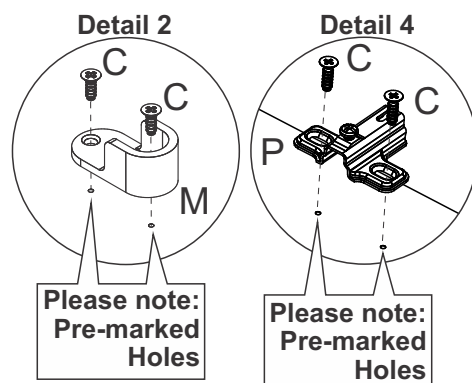
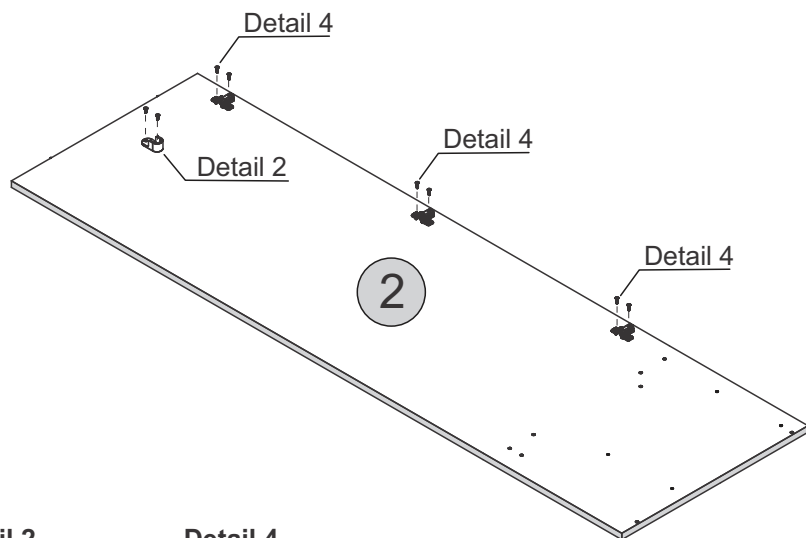
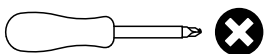

STEP 5

PARTS REQUIRED

2 -DIVISION PANEL x1

HARDWARE REQUIRED

A  04
Ø6,0 x 10mm

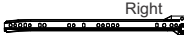
Q  02
Right

TOOLS REQUIRED

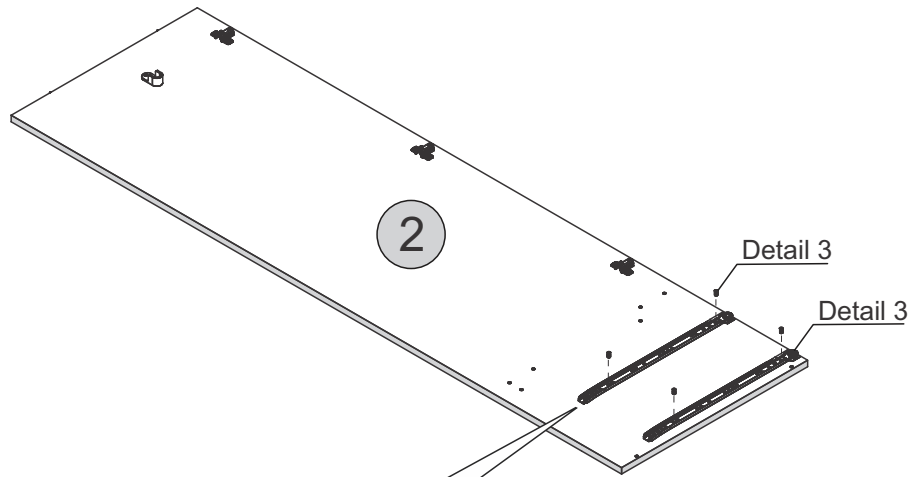
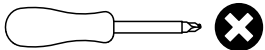

PLEASE NOTE
PRE-DRILLED
HOLES.

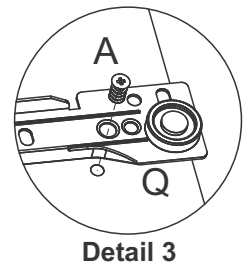
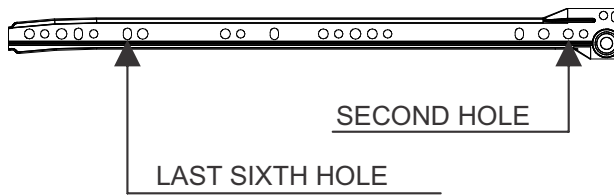

STEP 6

PARTS REQUIRED

6 - RIGHT SIDE PANEL x1

HARDWARE REQUIRED

C  08
Ø4,0 x 14mm

H  02

L  02

M  01

P  03

TOOLS REQUIRED

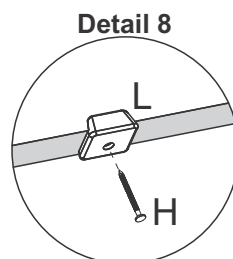
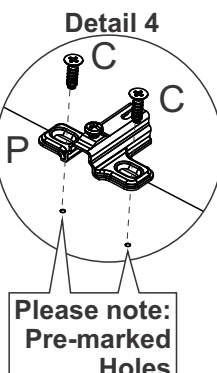
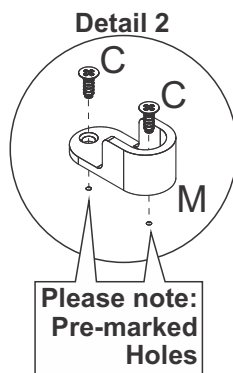
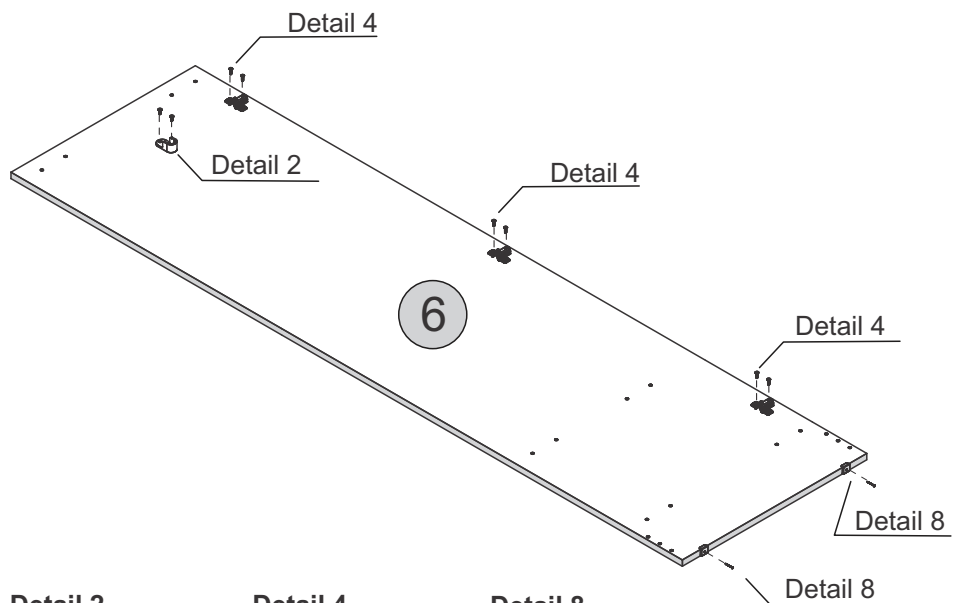
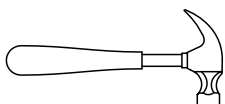
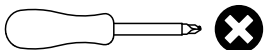

STEP 7

PARTS REQUIRED

7 -FRONT BASEBOARD x1

8 -BACK BASEBOARD x1

HARDWARE REQUIRED

H  02

L  02

G  08
Ø6,0 x 30mm

V  01

TOOLS REQUIRED

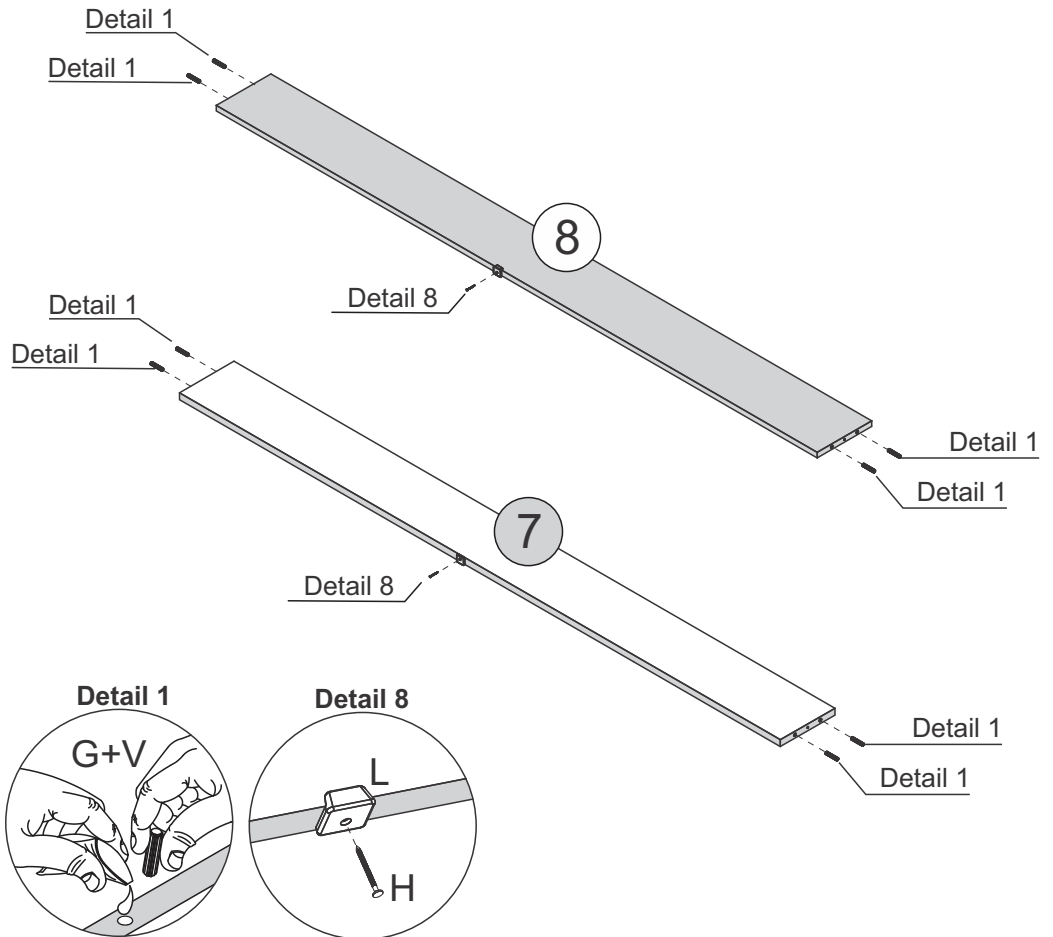
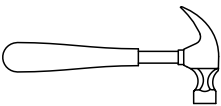
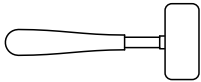

STEP 8

PARTS REQUIRED

1 - BASE PANEL x2

5 - SHELF x1

HARDWARE REQUIRED

G  12
Ø6,0 x 30mm

V  01

Z  04
Ø4,0 x 12mm

A1  02

TOOLS REQUIRED

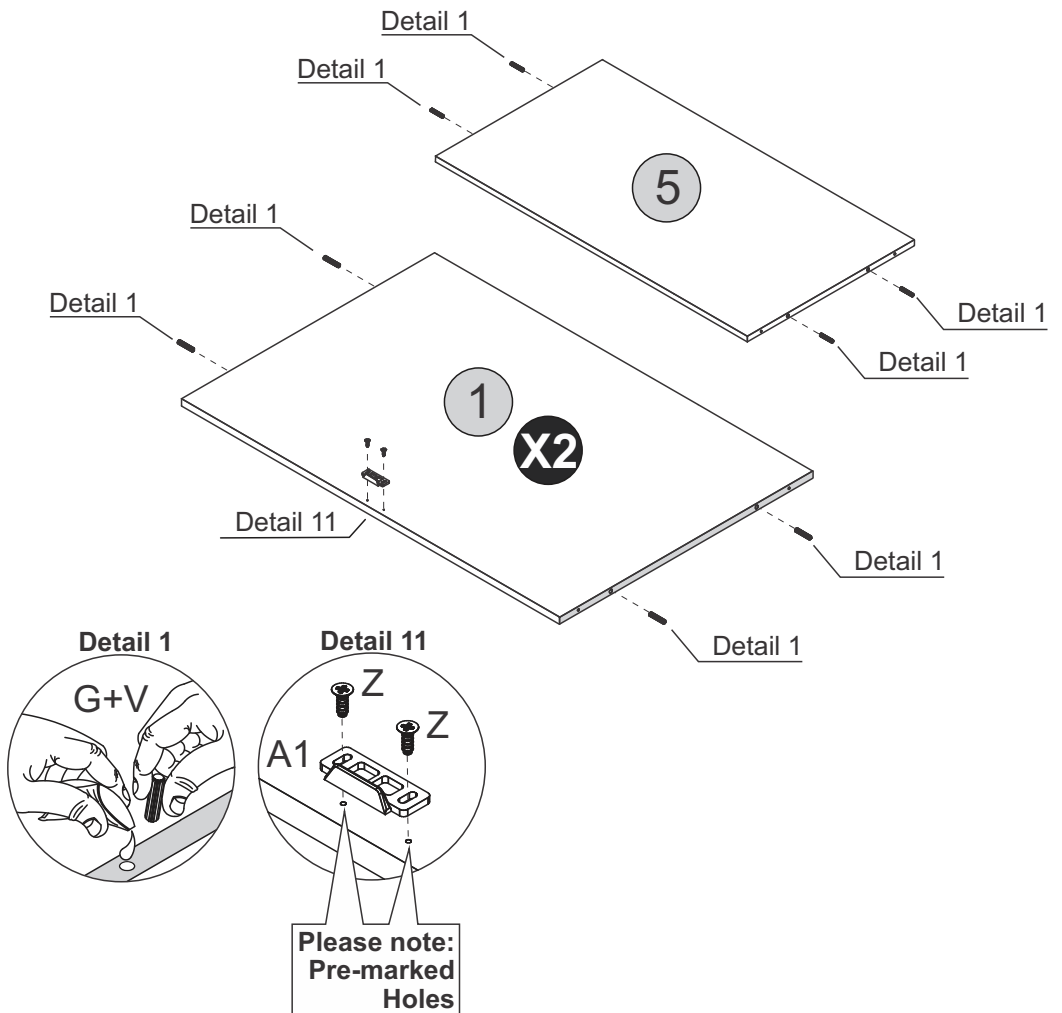
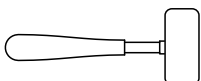
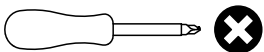



STEP 9

PARTS REQUIRED

3 -TOP PANEL x1

HARDWARE REQUIRED

G  04
Ø6,0 x 30mm

J  04

V  01
Glue

Z  08
Ø4,0 x 12mm

A1  02

TOOLS REQUIRED

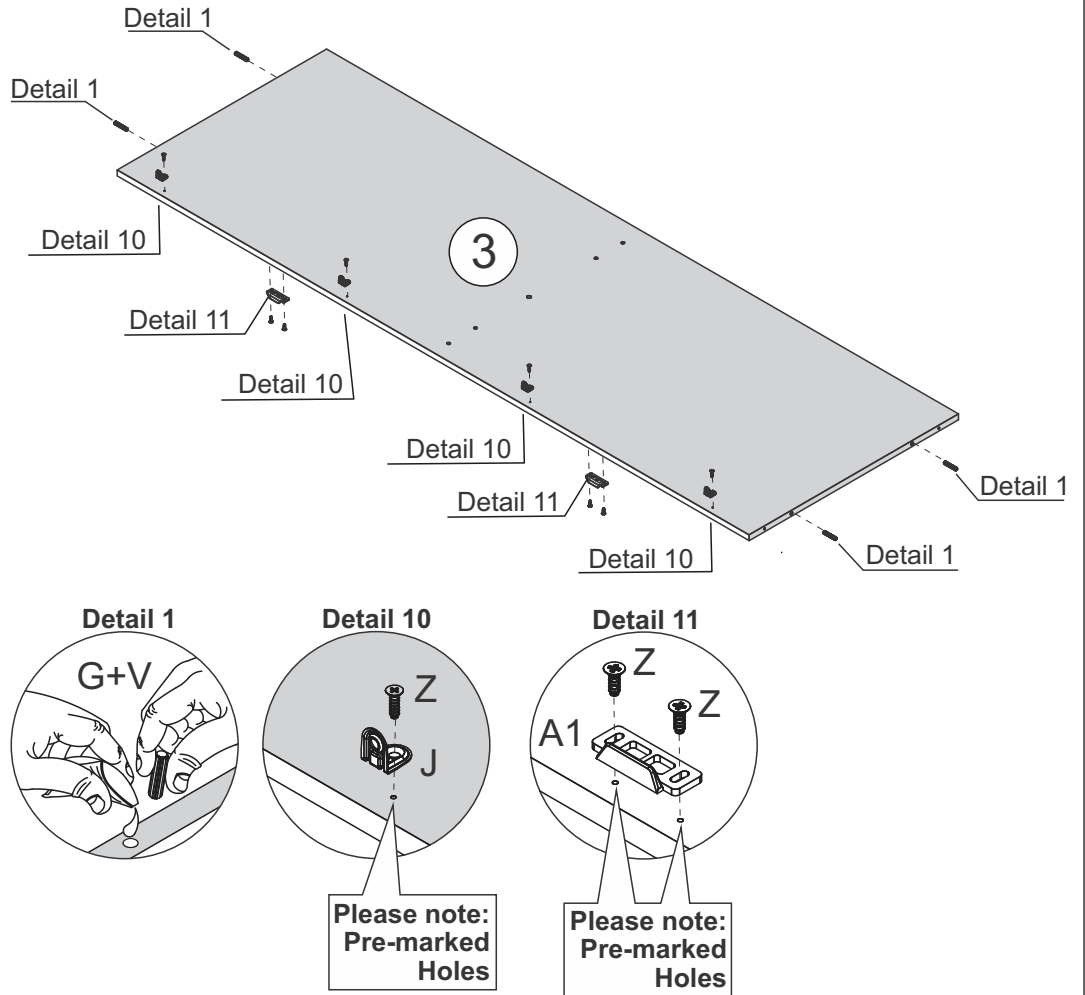
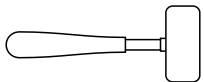
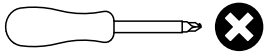

STEP 10

PARTS REQUIRED

1 -BASE PANEL x2

2 -DIVISION PANEL x1

3 -TOP PANEL x1

HARDWARE REQUIRED

F  06
Ø4,0 x 50mm

V  01
Glue

TOOLS REQUIRED

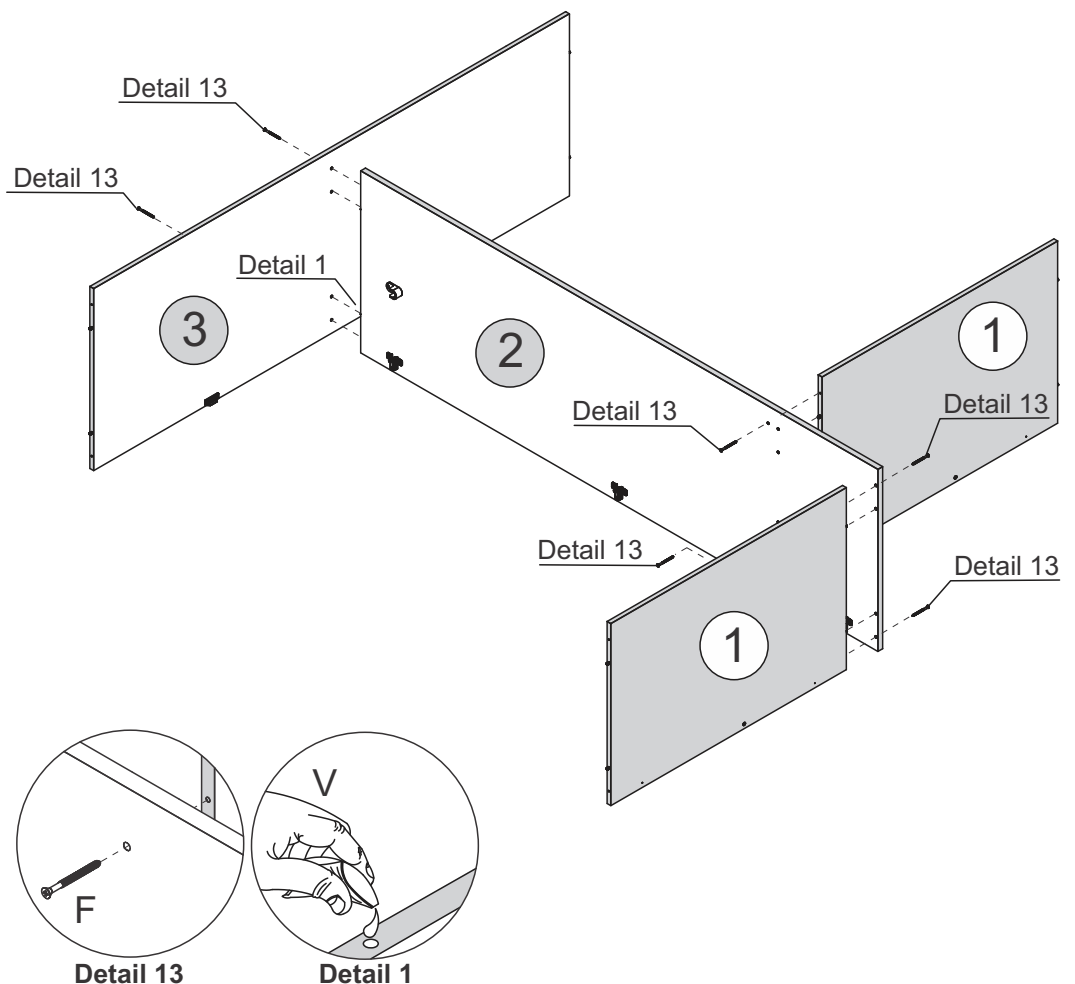
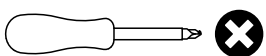

STEP 11

PARTS REQUIRED

4 -LEFT SIDE PANEL x1

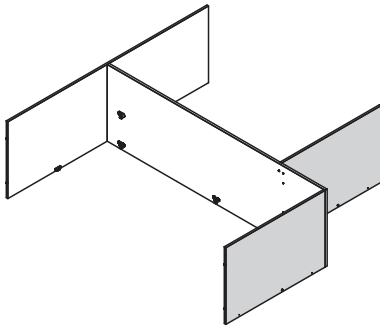

HARDWARE REQUIRED

F  Ø4,0 x 50mm 04

V  01

TOOLS REQUIRED

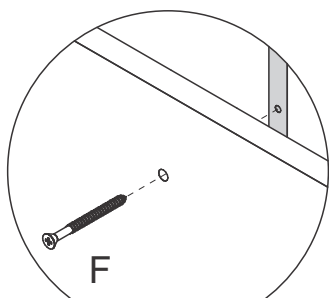
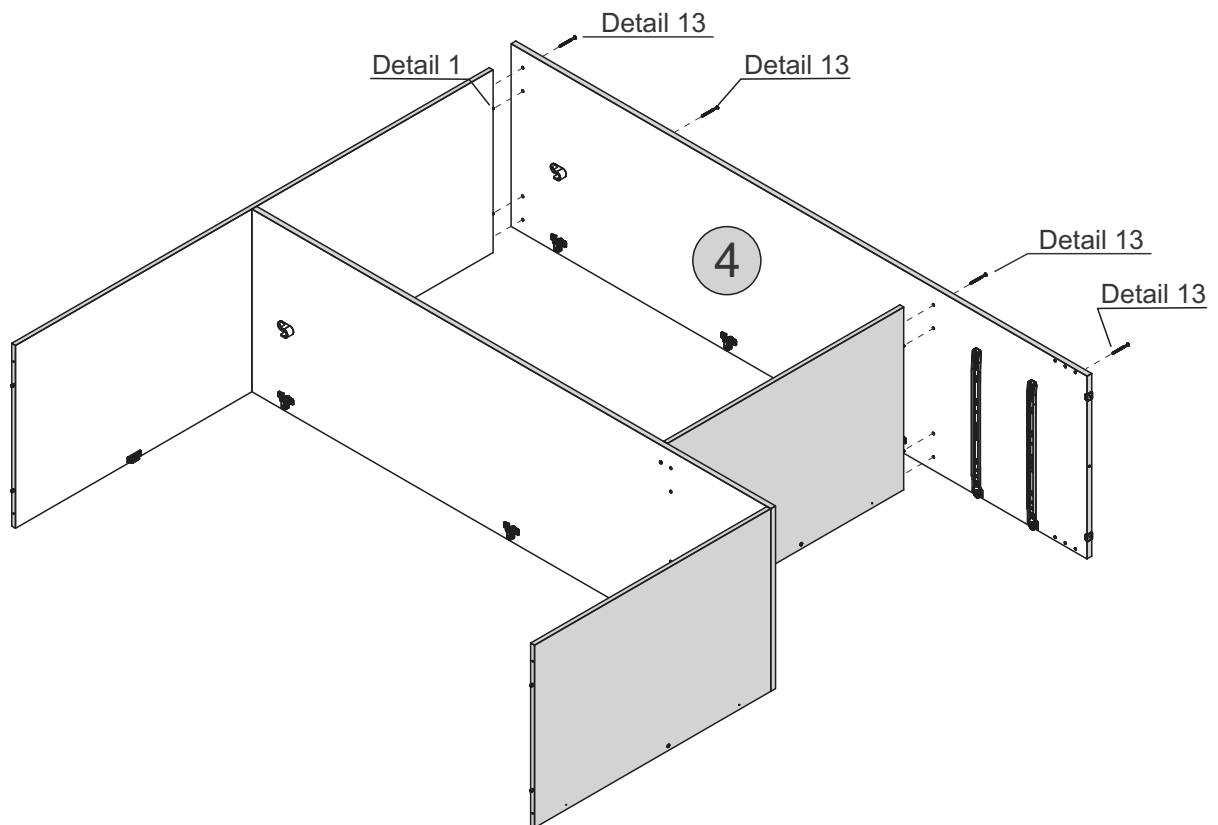
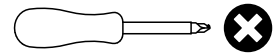

Detail 13

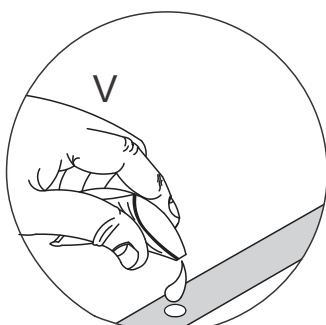



Detail 1

STEP 12

PARTS REQUIRED

5 -SHELF	x1
6 -RIGHT SIDE PANEL	x1
7 -FRONT BASEBOARD	x1
8 -BACK BASEBOARD	x1

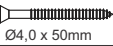
HARDWARE REQUIRED

F	  12
V	 01

TOOLS REQUIRED

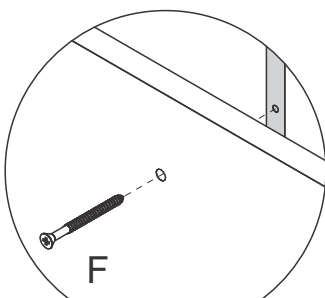
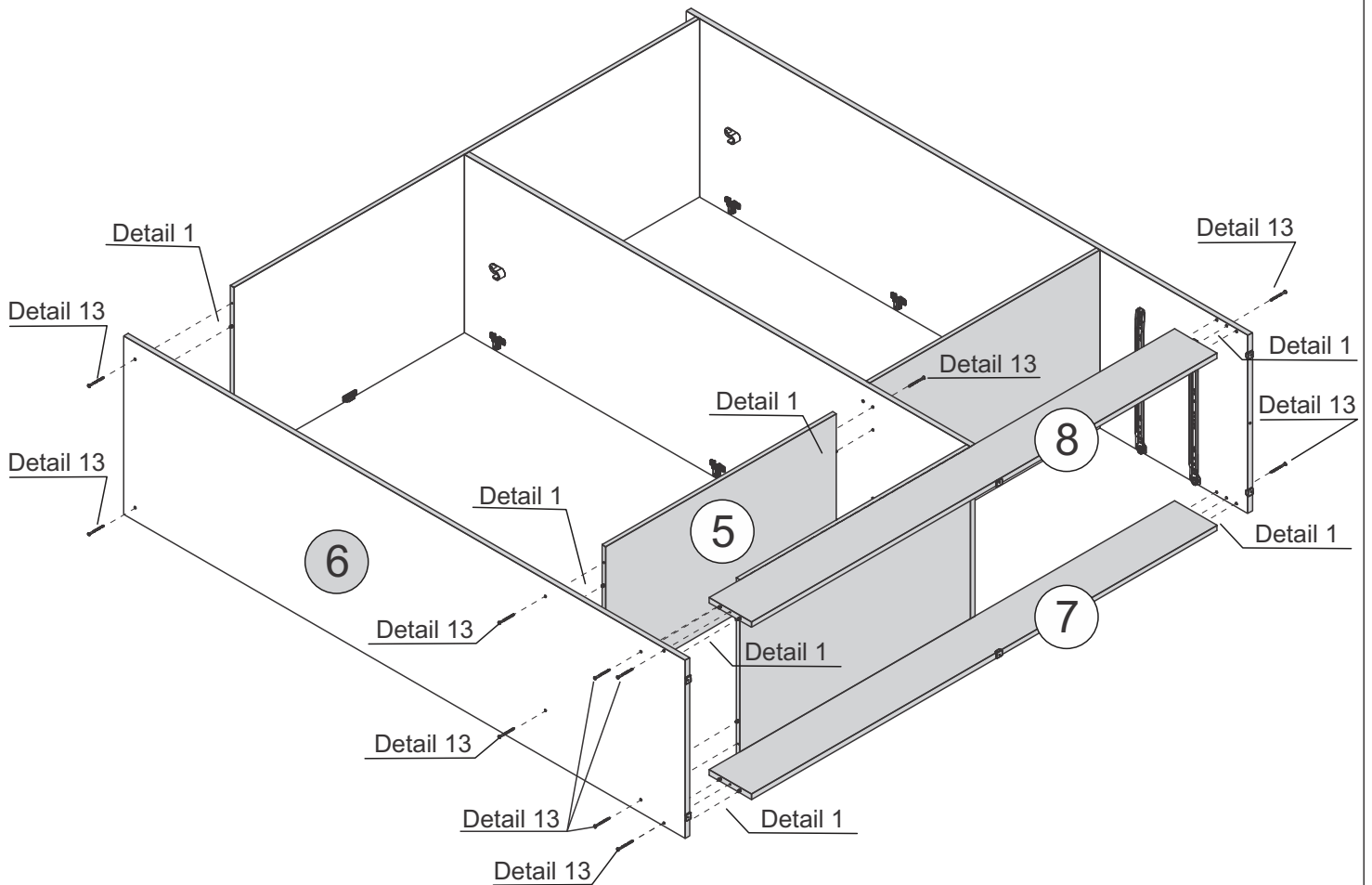
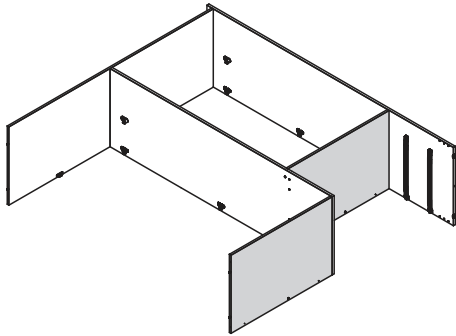
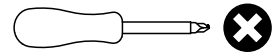

Detail 13

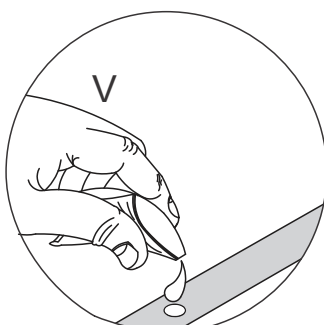

Detail 1

STEP 13

PARTS REQUIRED

9 - BACK PANEL x4

HARDWARE REQUIRED

B  12
Ø4,0 x 14mm

H  12
10 x 10

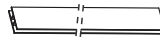
R  02

TOOLS REQUIRED

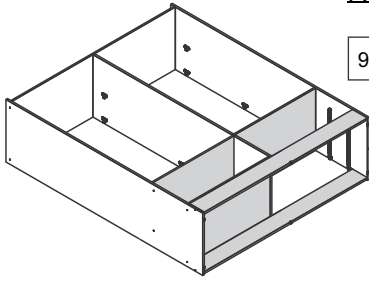
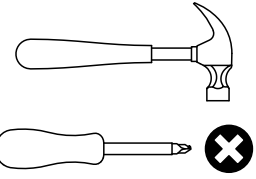

IMPORTANT PLEASE FOLLOW !

Please make sure Part 9 is lined up correctly at the top before placing fitting H into the panel as this can affect the alignment of the doors once assembled.

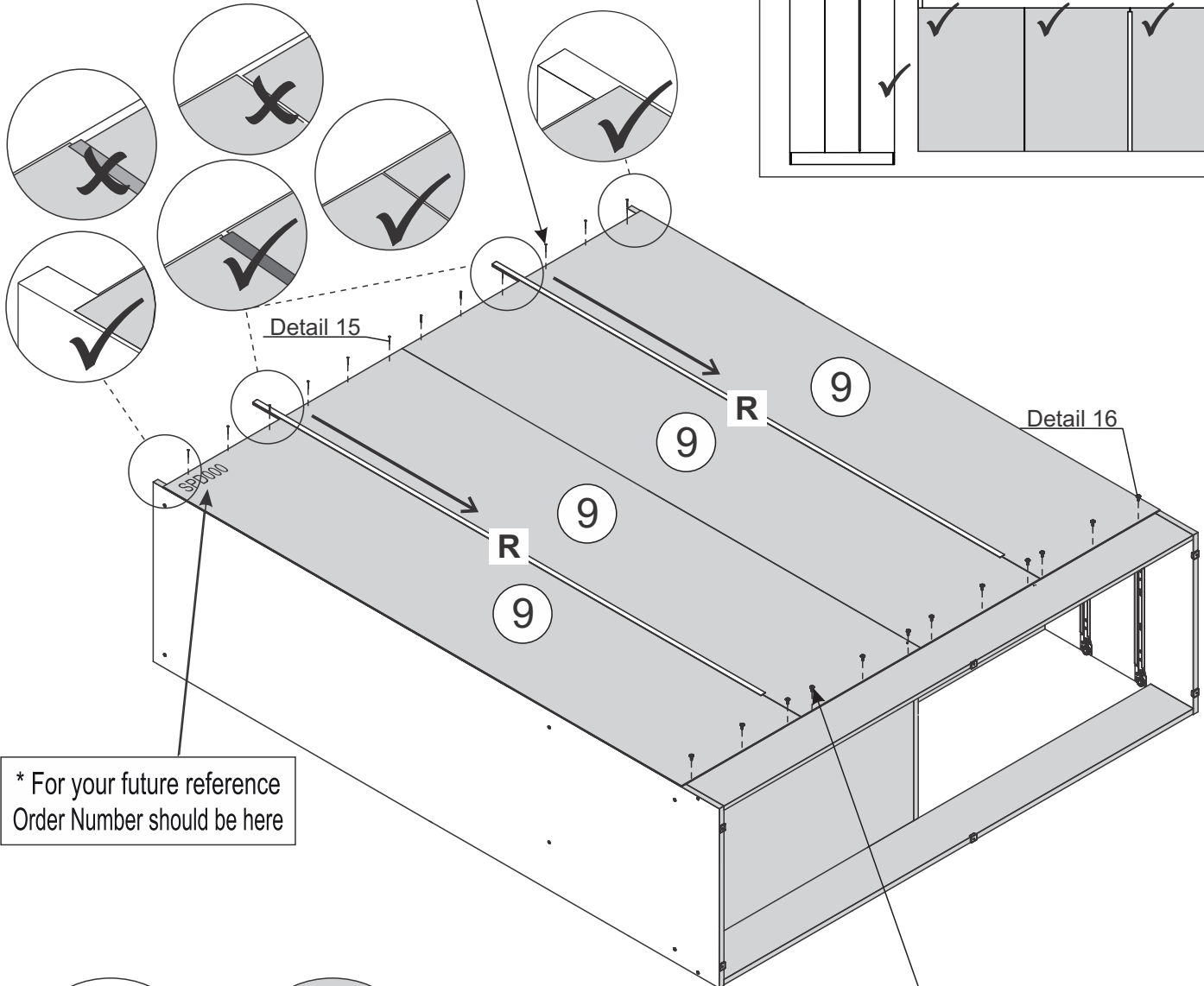
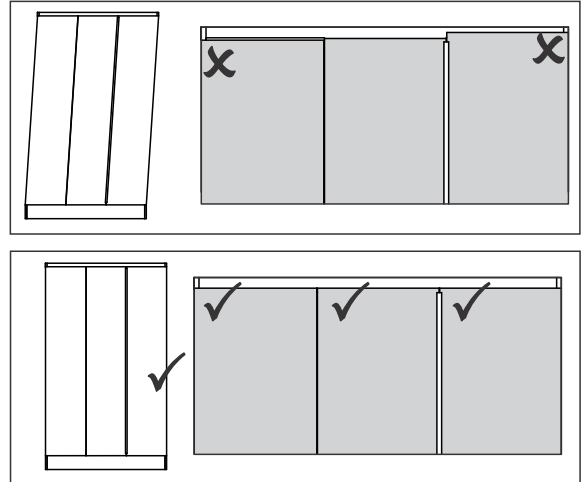

* For your future reference Order Number should be here

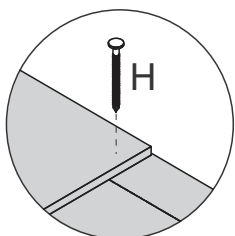

Detail 15

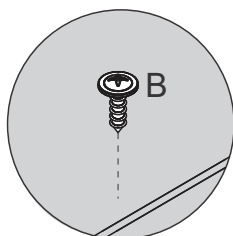

Detail 16

IMPORTANT PLEASE FOLLOW !



Please make sure Part 9 isn't overhanging at the sides before you screw fitting B into the plinth.

STEP 14

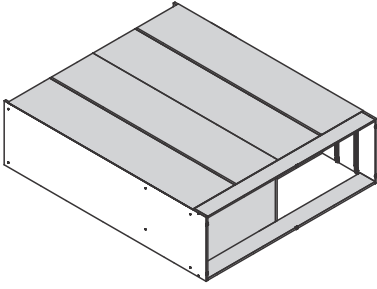
PARTS REQUIRED



HARDWARE REQUIRED

H	 10 x 10	50
I		16

TOOLS REQUIRED

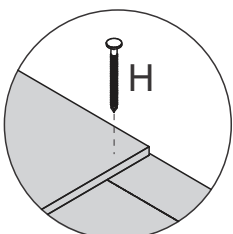
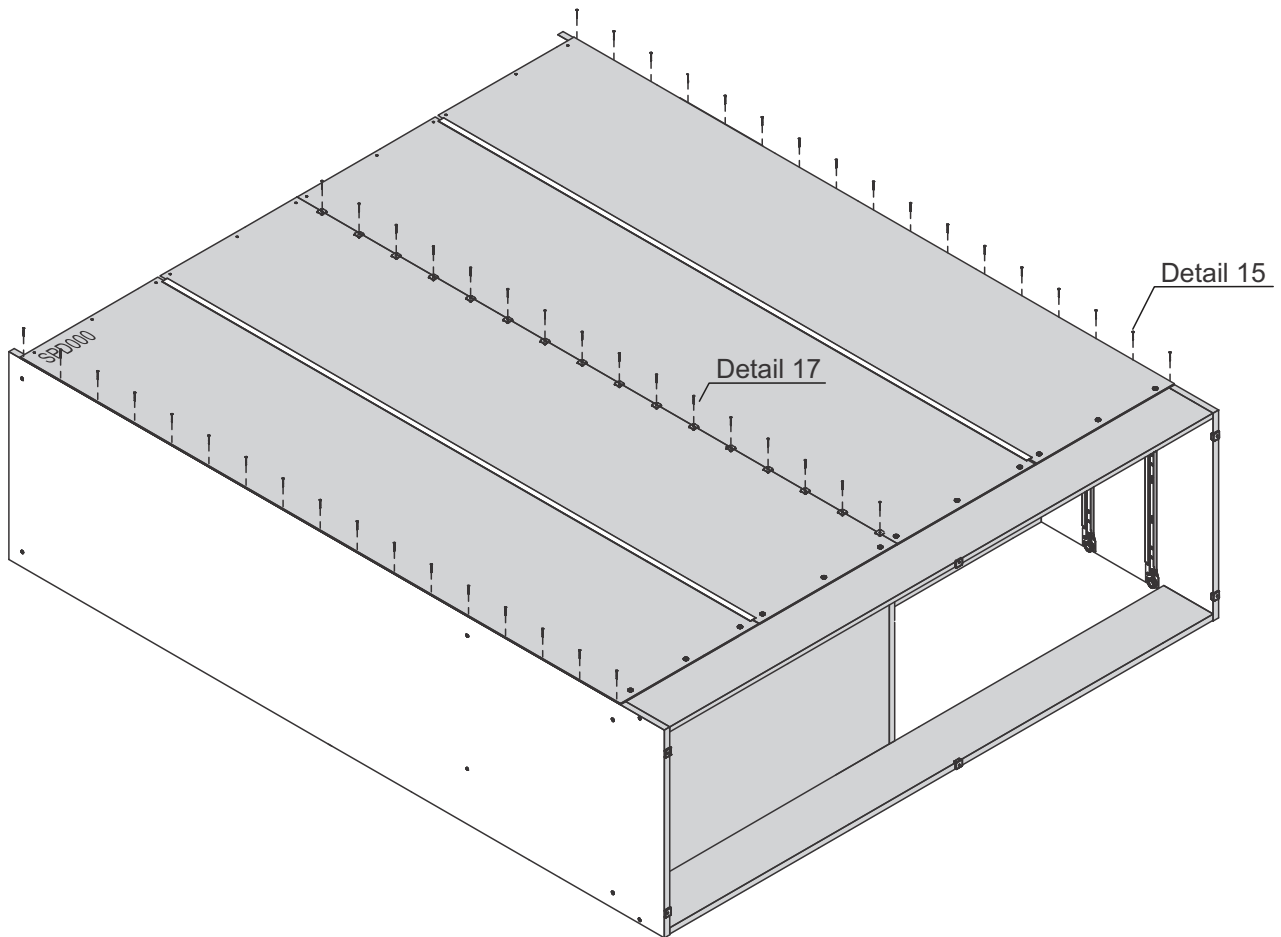
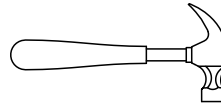

Detail 15

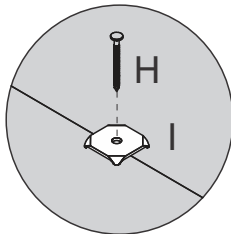

Detail 17

STEP 15

PARTS REQUIRED

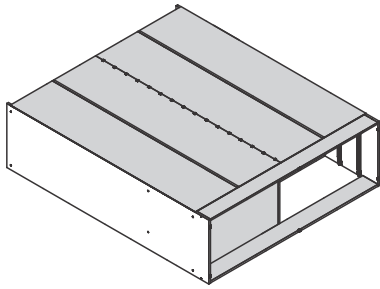

HARDWARE REQUIRED

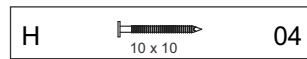

TOOLS REQUIRED

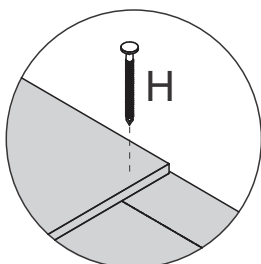
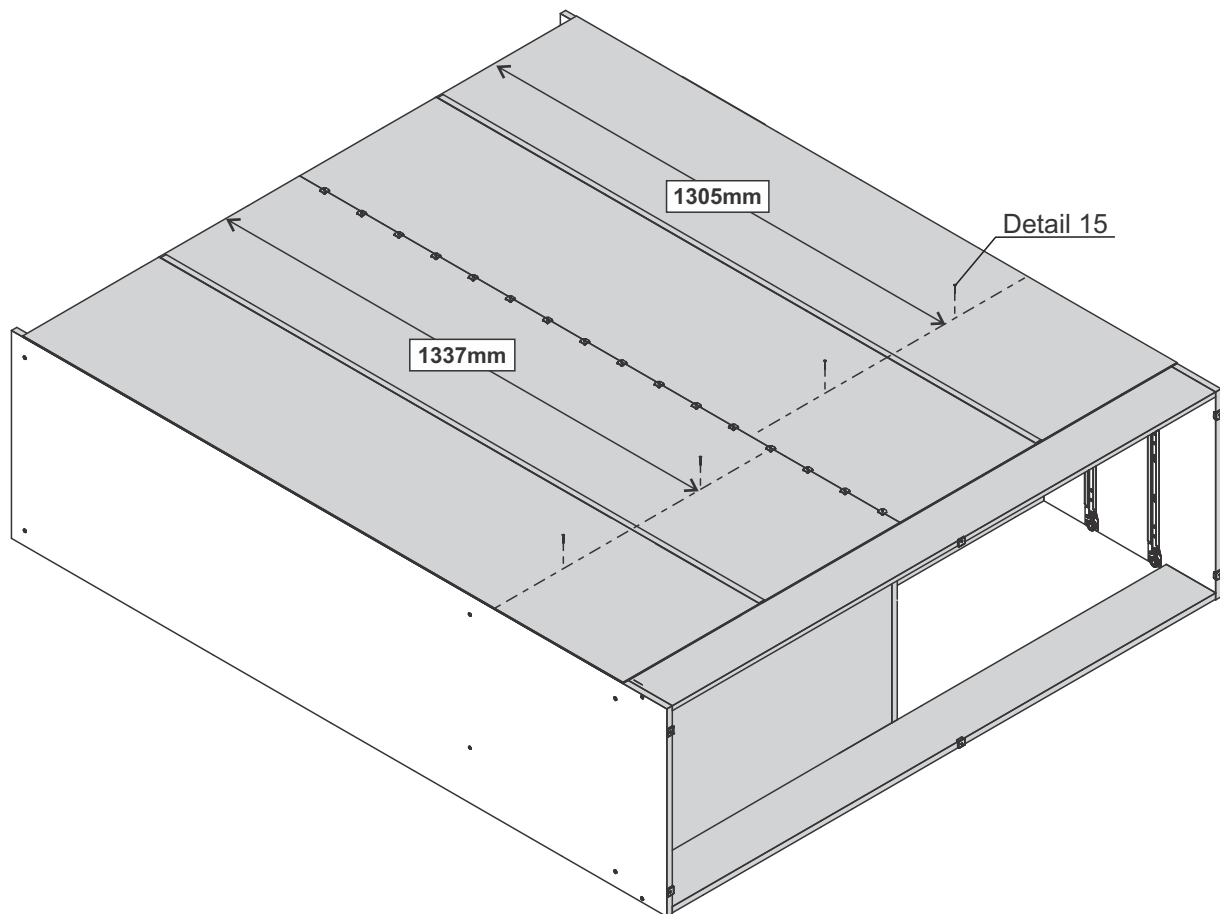
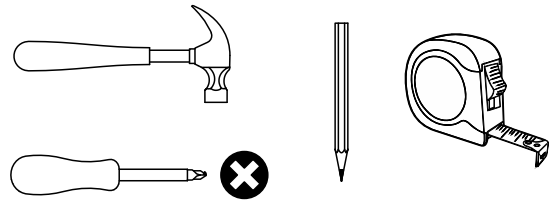

Detail 15

STEP 16

PARTS REQUIRED

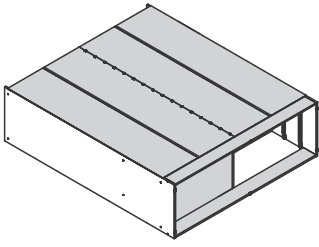

HARDWARE REQUIRED

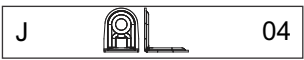

TOOLS REQUIRED

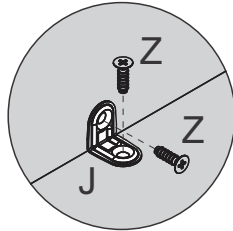
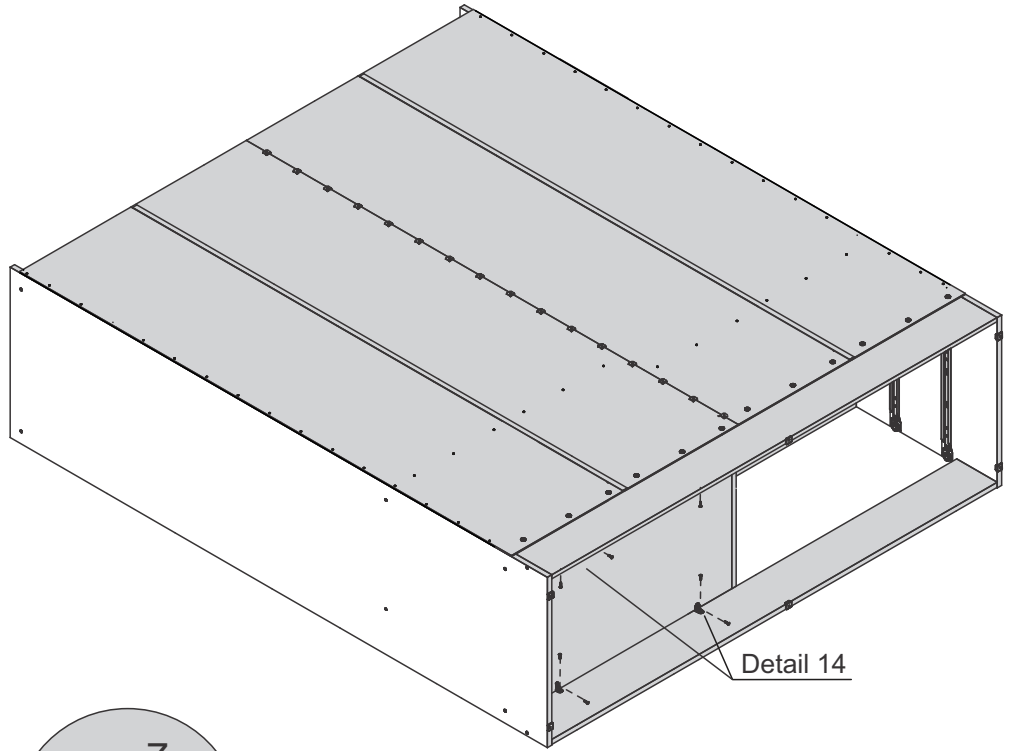
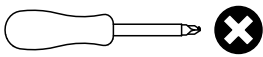

Detail 14

STEP 17

PARTS REQUIRED

10 - FRAME	x1
------------	----

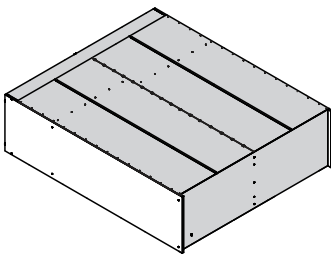

HARDWARE REQUIRED

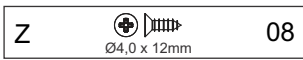
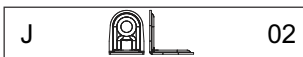

TOOLS REQUIRED

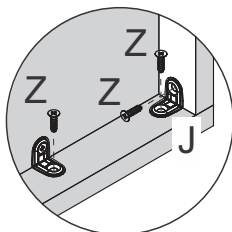
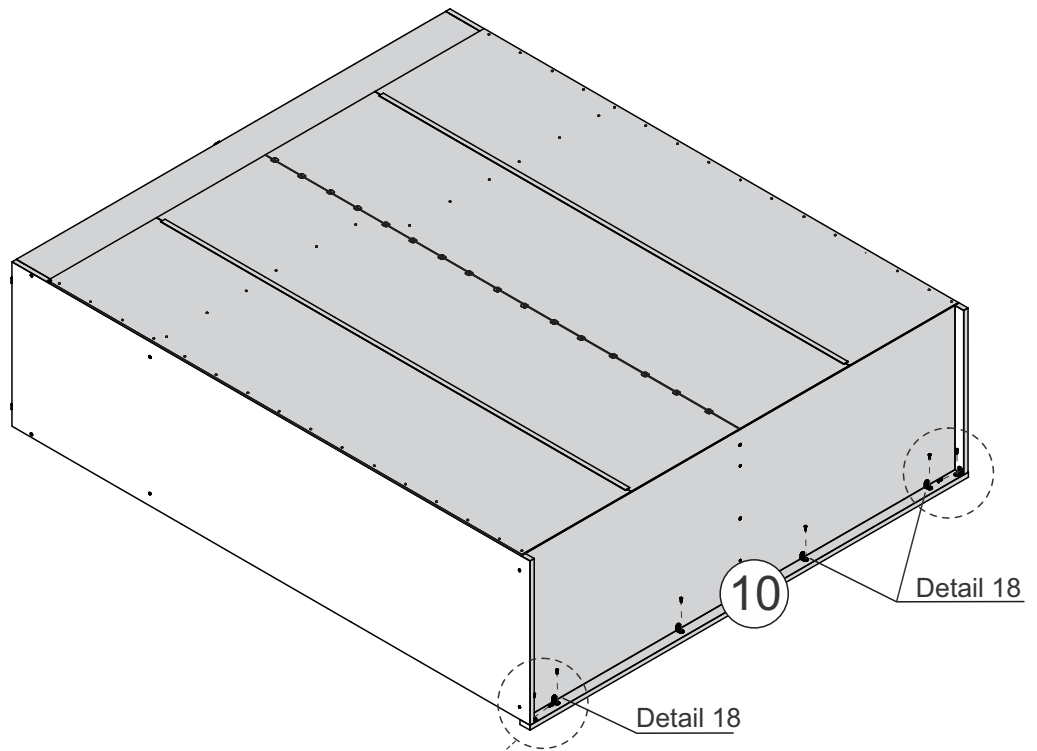
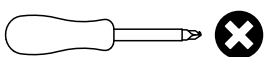

Detail 18

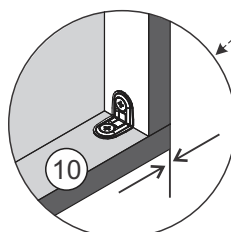



Align corners

STEP 18

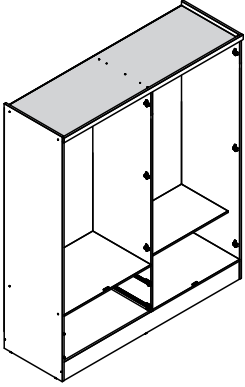
PARTS REQUIRED



HARDWARE REQUIRED

Y		02
B1		02

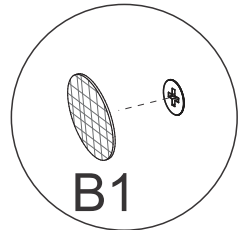
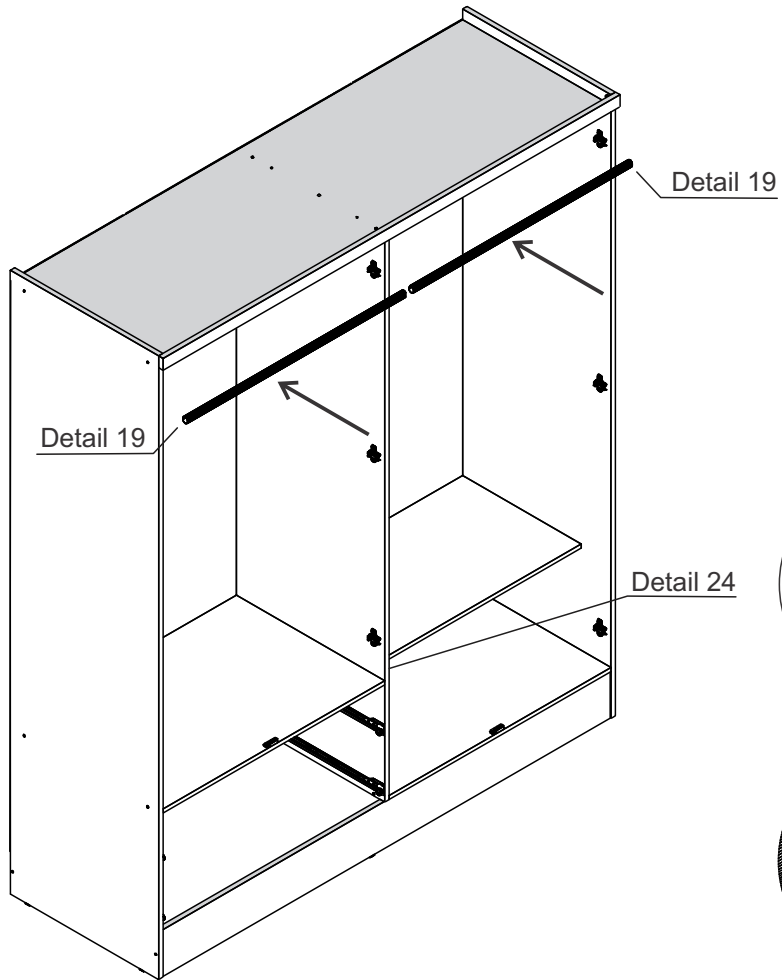

Detail 24

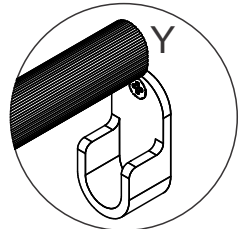



Detail 19

STEP 19

PARTS REQUIRED

15 - DRAWER SIDE	x4
16 - DRAWER BACK PANEL	x2
19 - DRAWER BOTTOM SUPPORT BAR	x2

HARDWARE REQUIRED

G		20
V		01

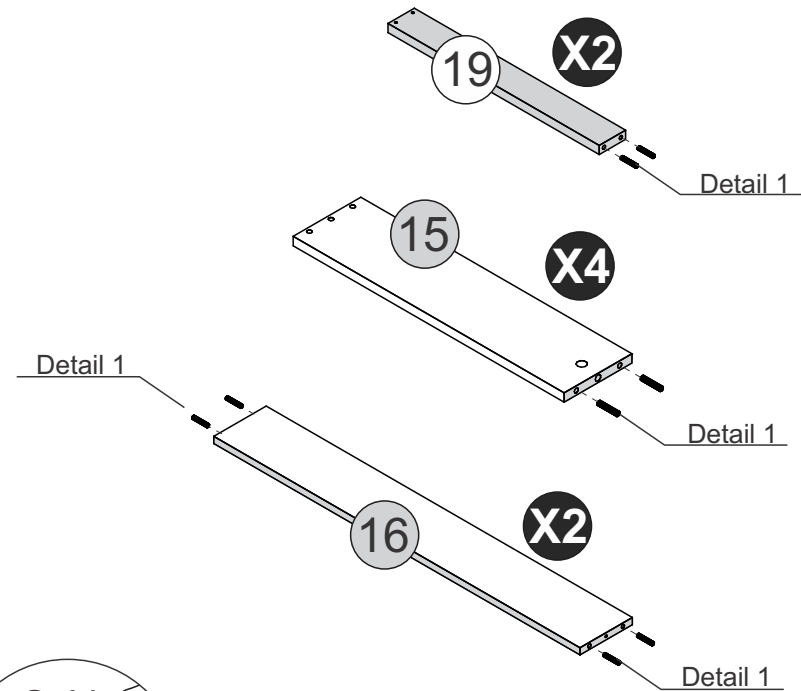

Detail 1

STEP 20

PARTS REQUIRED

17 - DRAWER FRONT x2

HARDWARE REQUIRED

X  04

TOOLS REQUIRED

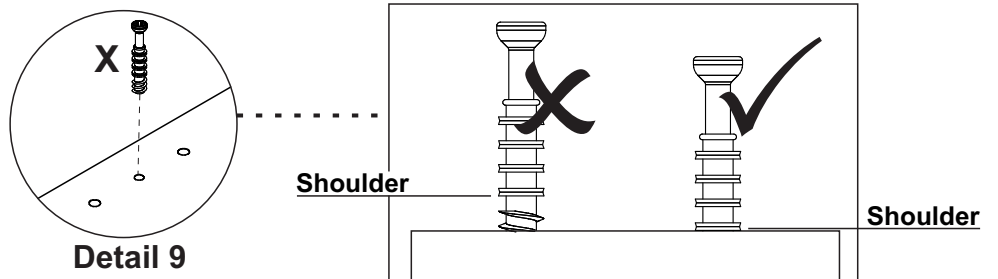
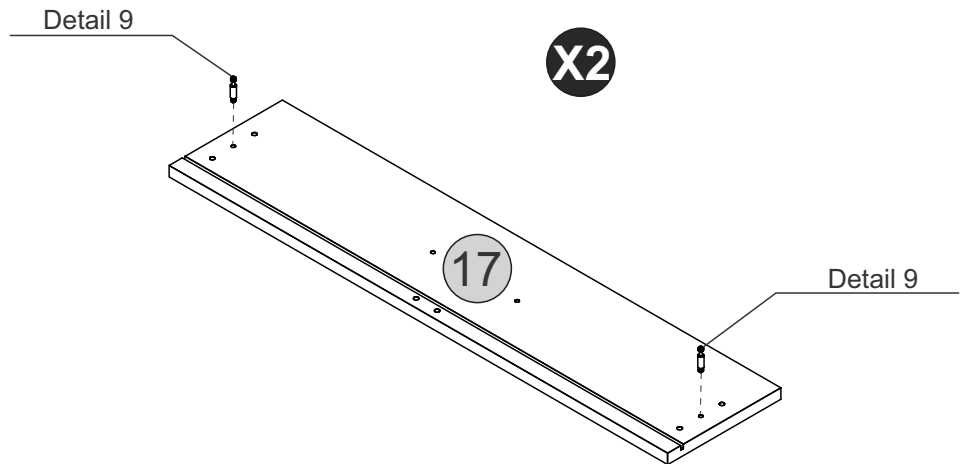
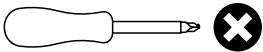

STEP 21

PARTS REQUIRED

15 - DRAWER SIDE x4

16 - DRAWER BACK PANEL x2

HARDWARE REQUIRED

F  Ø4,0 x 50mm 04

TOOLS REQUIRED

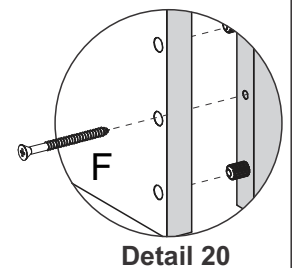
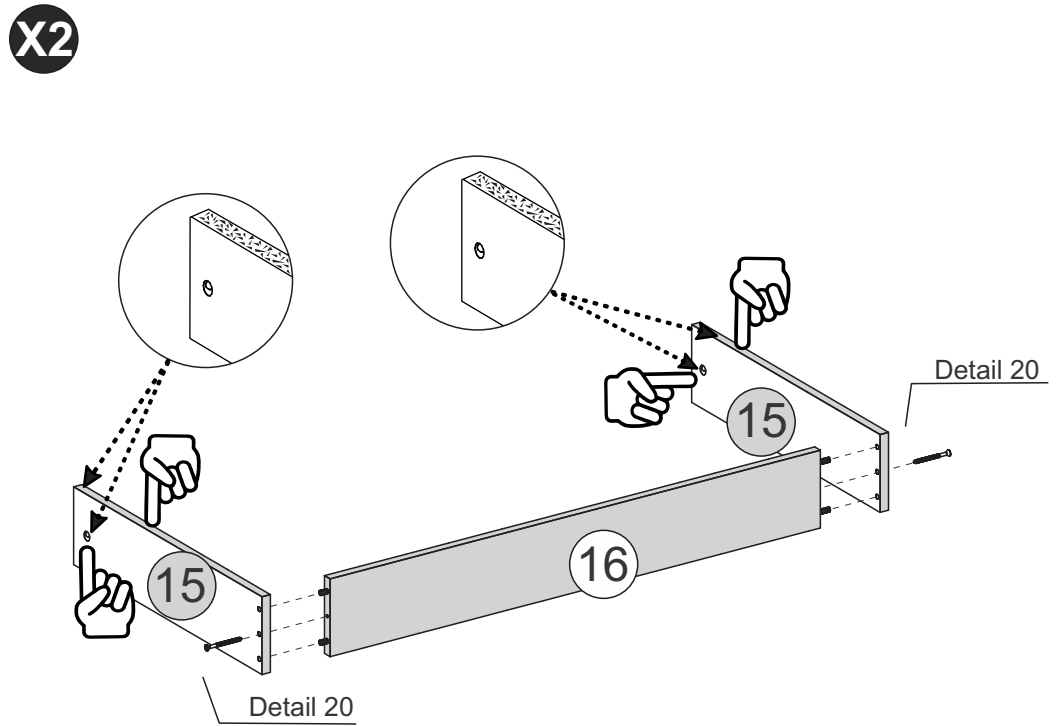
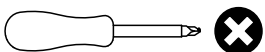

STEP 22

PARTS REQUIRED

17 - DRAWER FRONT x2

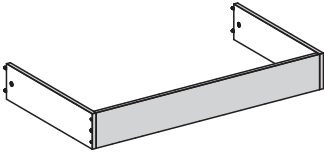

HARDWARE REQUIRED

B1  04

V  01

W  04

TOOLS REQUIRED

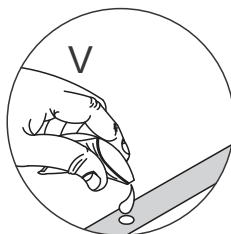
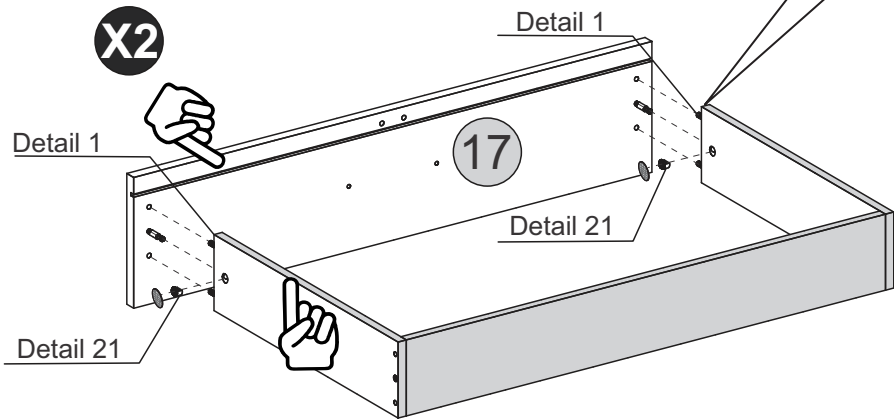
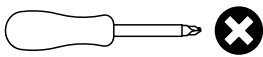

Detail 1

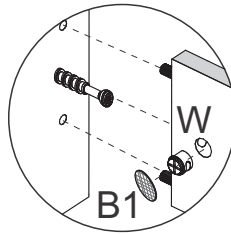

Detail 21

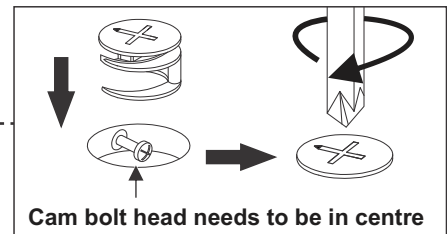

Cam bolt head needs to be in centre

STEP 23

PARTS REQUIRED

18 - DRAWER BOTTOM x2

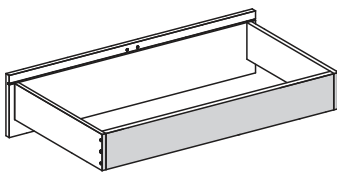

HARDWARE REQUIRED

H  08

TOOLS REQUIRED

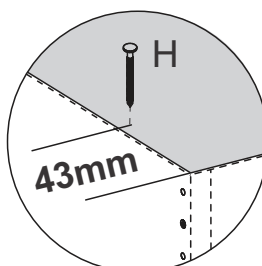
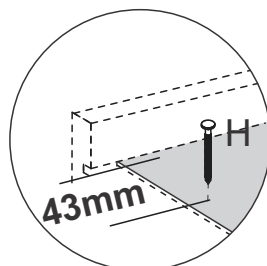
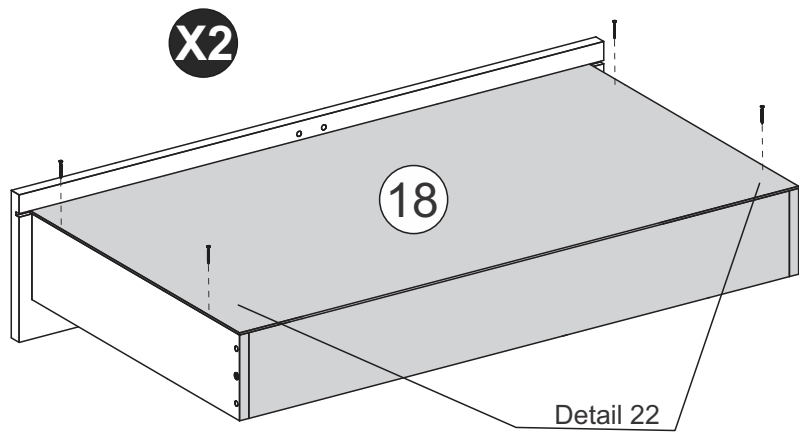
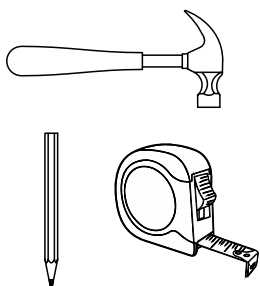

Detail 22

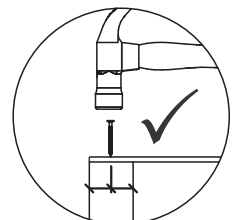
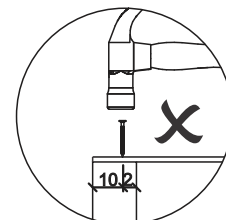
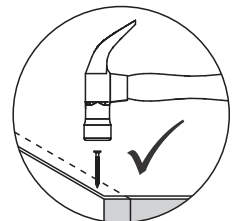
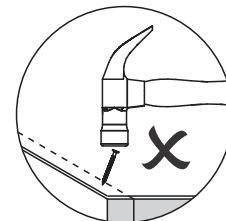

STEP 24

PARTS REQUIRED

19 - DRAWER BOTTOM SUPPORT BAR X2

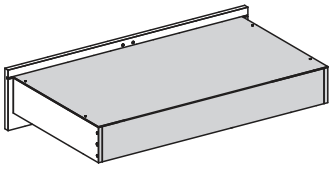

HARDWARE REQUIRED

H  12

V  01

TOOLS REQUIRED

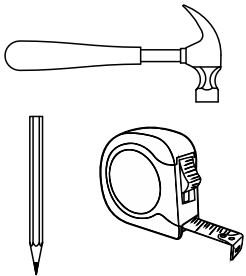

X2

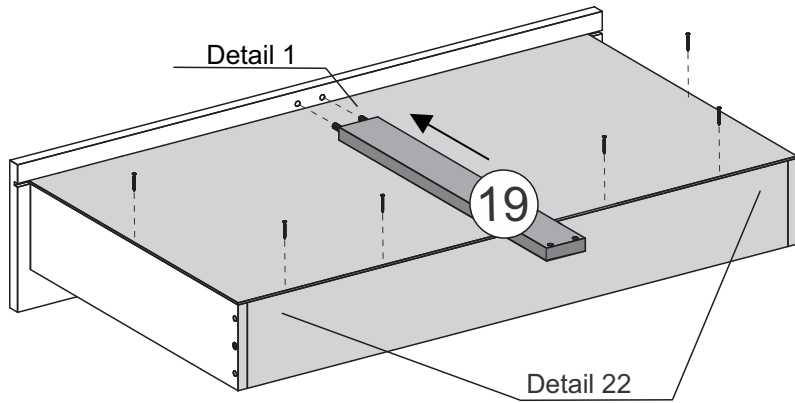

Detail 1

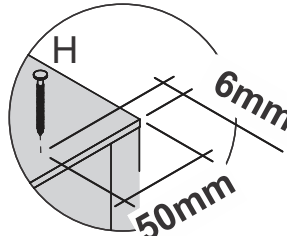

Detail 22

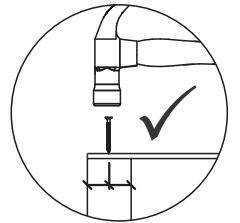
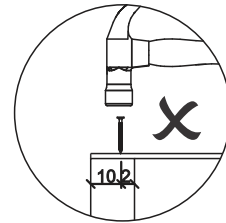
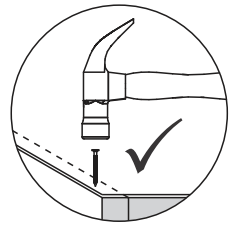
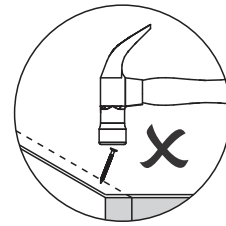

STEP 25

PARTS REQUIRED

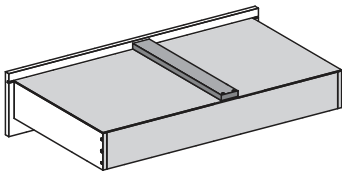

HARDWARE REQUIRED

C  08

E  04

Q  02

Q  02

TOOLS REQUIRED

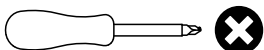

X2

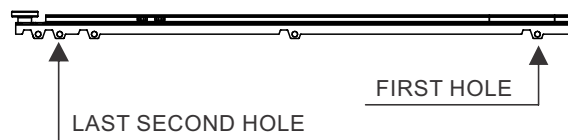
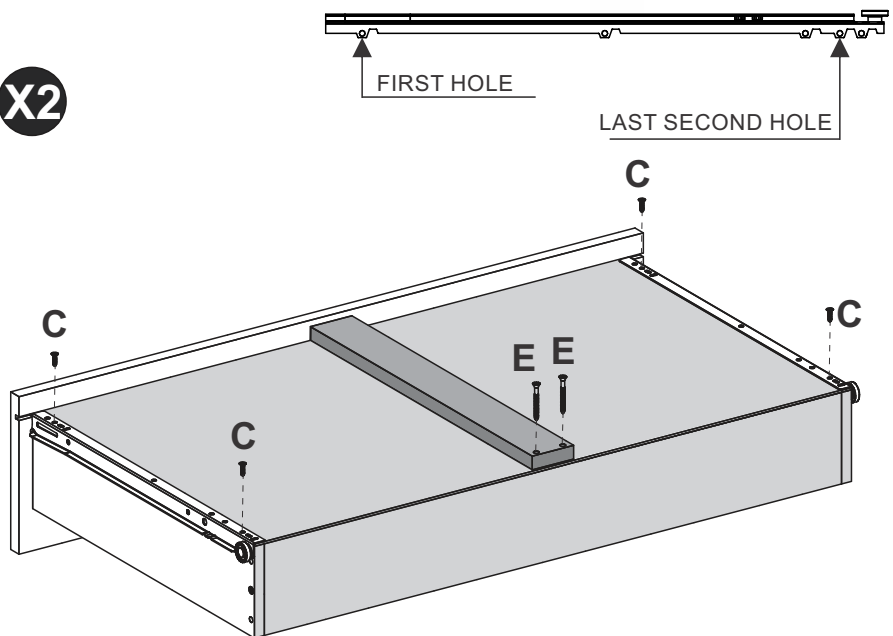

STEP 26

PARTS REQUIRED

11 -RIGHT LARGE DOOR x1

12 -LEFT LARGE DOOR x1

13 -RIGHT SMALL DOOR x1

14 -LEFT SMALL DOOR x1

HARDWARE REQUIRED

C  24
Ø4,0 x 14mm

O  12

TOOLS REQUIRED

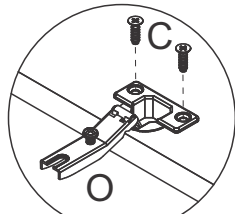
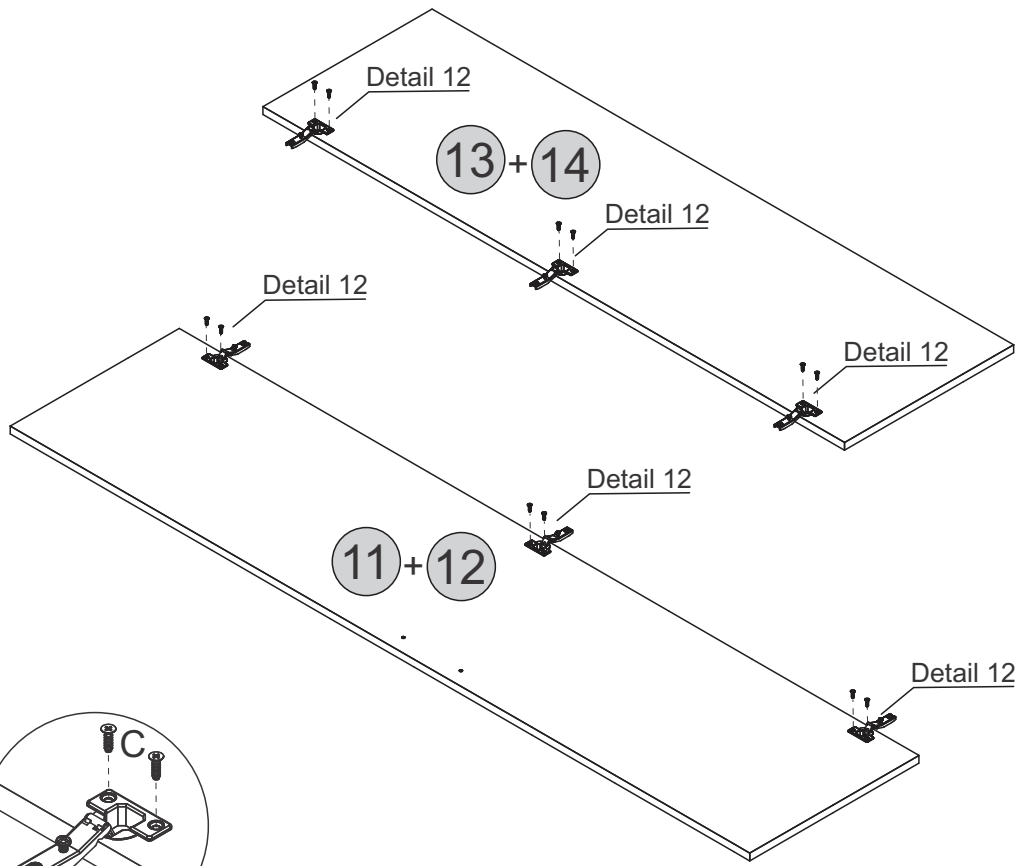
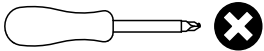

Detail 12

STEP 27

PARTS REQUIRED

11 -RIGHT LARGE DOOR x1

12 -LEFT LARGE DOOR x1

13 -RIGHT SMALL DOOR x1

14 -LEFT SMALL DOOR x1

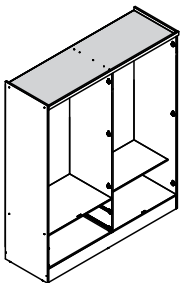

HARDWARE REQUIRED

U  14

TOOLS REQUIRED

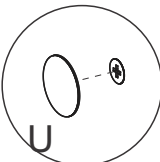
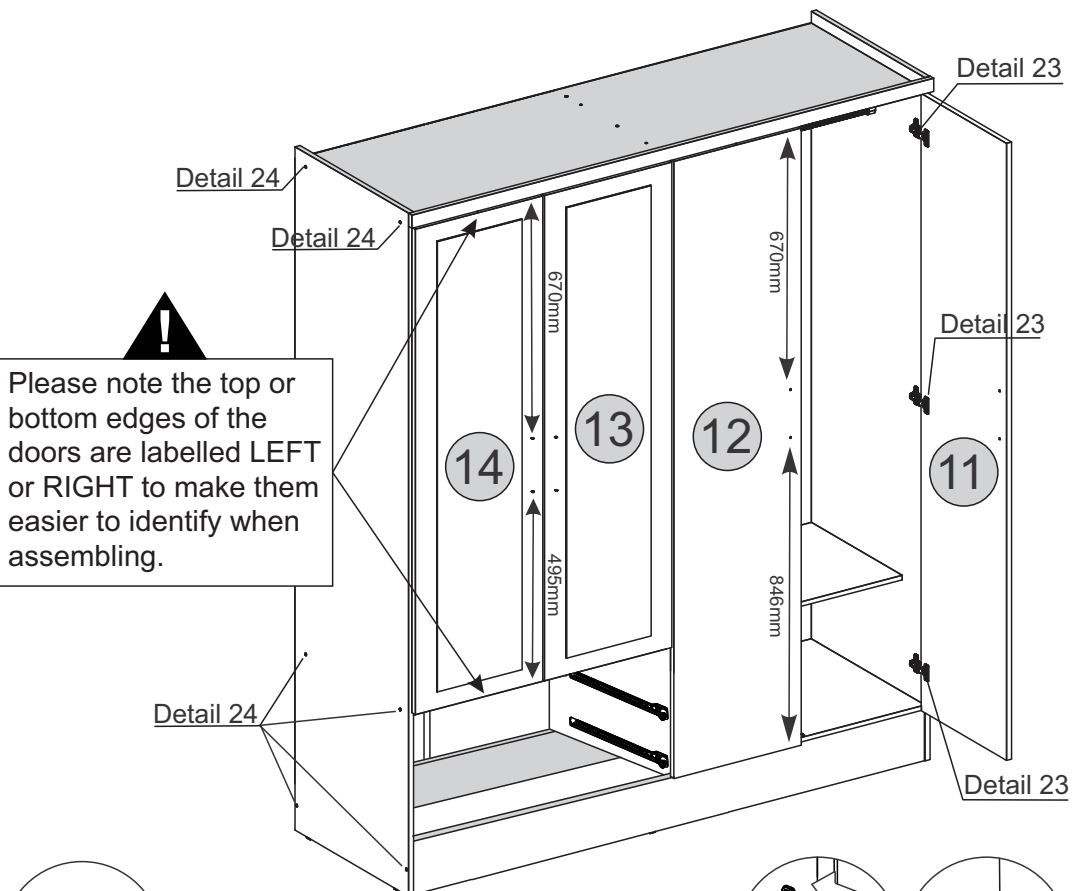
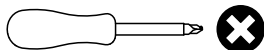

Detail 24

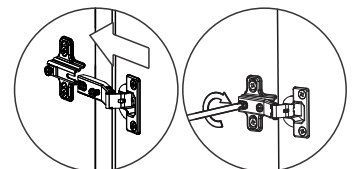

Detail 23

STEP 28

PARTS REQUIRED

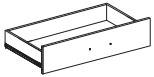
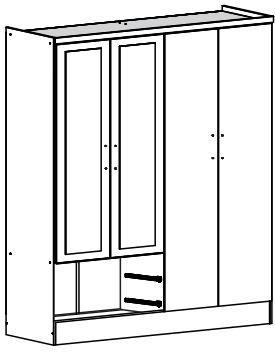

HARDWARE REQUIRED

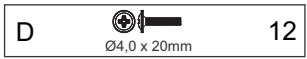

TOOLS REQUIRED

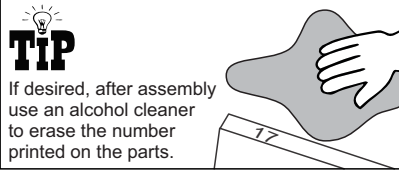
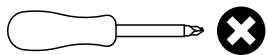

See the last page.

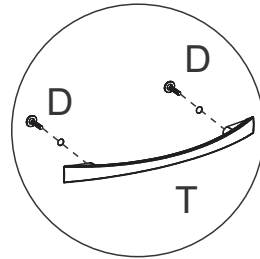
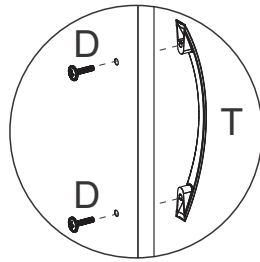

Detail 25

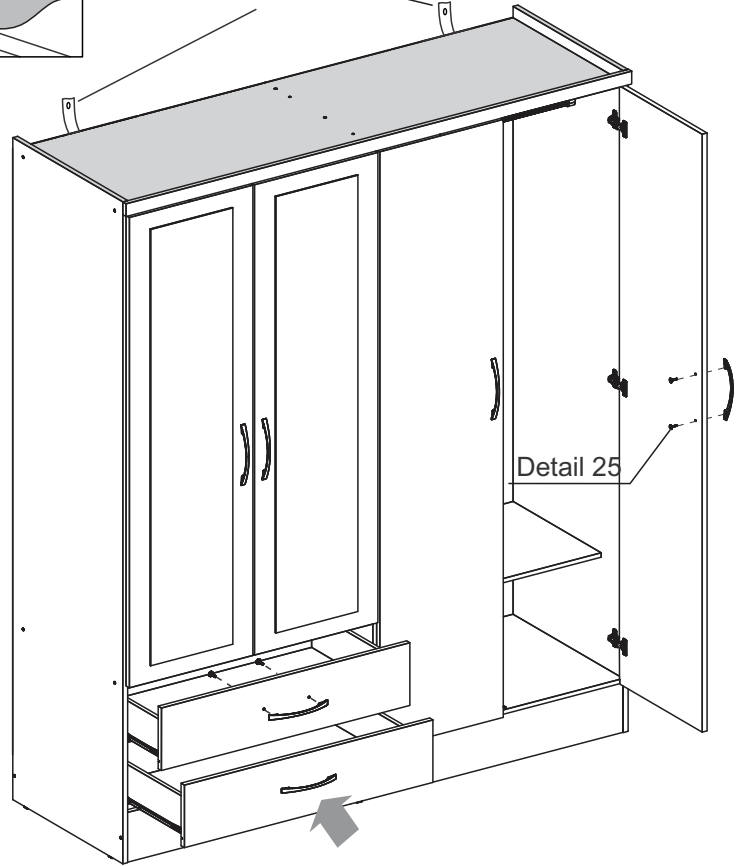

STEP 29

PARTS REQUIRED

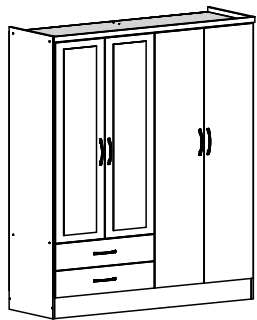

HARDWARE REQUIRED

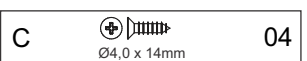

TOOLS REQUIRED

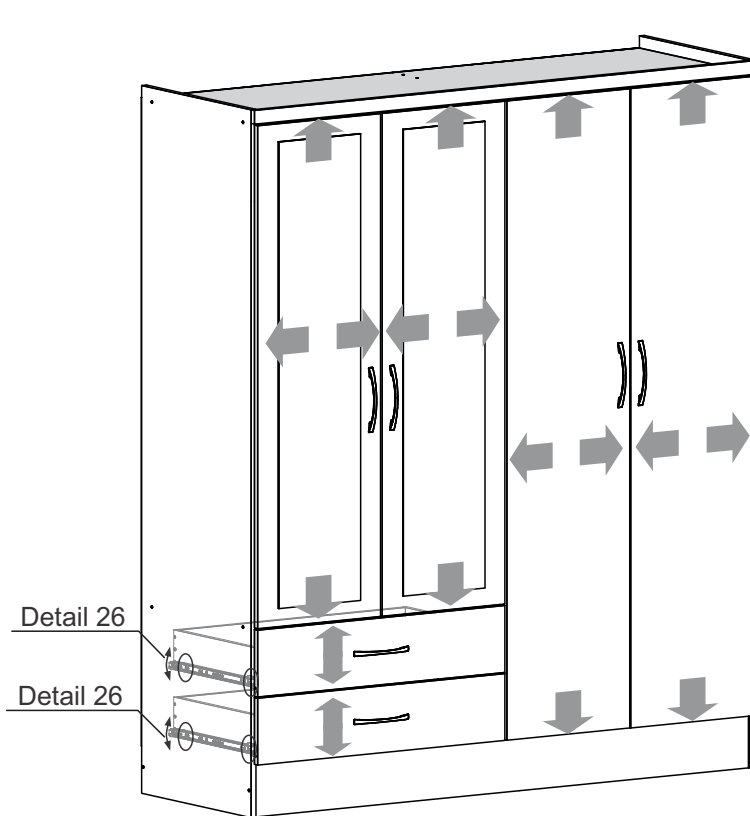
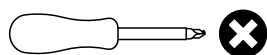

Drawer Adjustment

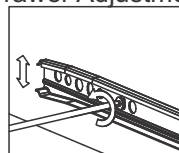

Drawer Lock

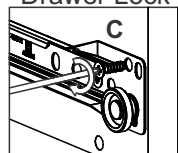

Detail 26

Height Adjustment

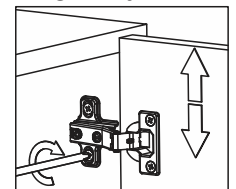

Internal Adjustment

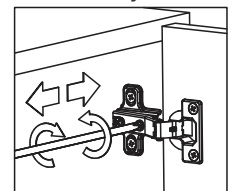

Depth Adjustment

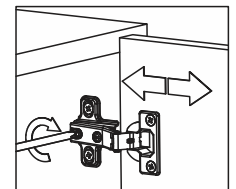
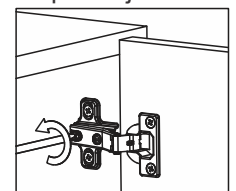

WARNING

Serious or fatal injuries can occur from furniture tipping over. To prevent the furniture from tipping over we recommend that it is permanently fixed to the wall.

Wall fixings are not supplied with this product as different wall materials require different types of fixing devices. Please make sure you use fixings suitable for the walls in your home.

