

WHITE NAPLES TALL BOOKCASE ASSEMBLY INSTRUCTIONS

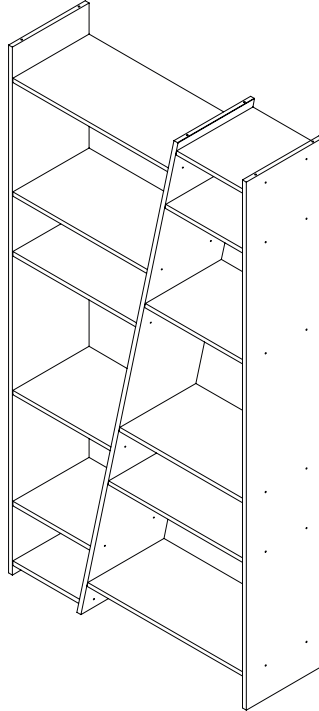

IMPORTANT FOR DOMESTIC USE ONLY

PLEASE READ BEFORE YOU CONTINUE FURTHER

CARE AND MAINTENANCE

After unpacking this product please keep the original packaging in case it needs to be returned for any reason.

- Please ensure all fittings and parts are present before commencing with assembly.
- Never drag or push products as this could cause damage to the joints making it inferior.
- We strongly recommend that you keep children away from your work area.
- We recommend that you lay a blanket or sheet on the floor to avoid damage to both your floor and the product.
- Assemble this product as close to its final position as possible.
- Do not place this product next to a radiator or in direct sunlight.
- Do not drag or push items across your high gloss furniture as this may cause the surface to scratch
- Wood is a natural product and may expand if subjected to damp and may shrink or crack if subjected to heat. Therefore it is recommended that room temperature is maintained, with no sudden temperature fluctuations.
- Make sure any spillage is wiped off immediately.
- Do not place hot or chilled items directly on to the surface, use a place mat or marking will occur.
- For general cleaning use a soft cotton or micro fibre cloth, and do not use detergents of any kind.
- From time to time it may be necessary to tighten fittings, regular inspections should be carried out.
- Do not place on a wet or damp floor as staining may occur to your floor.

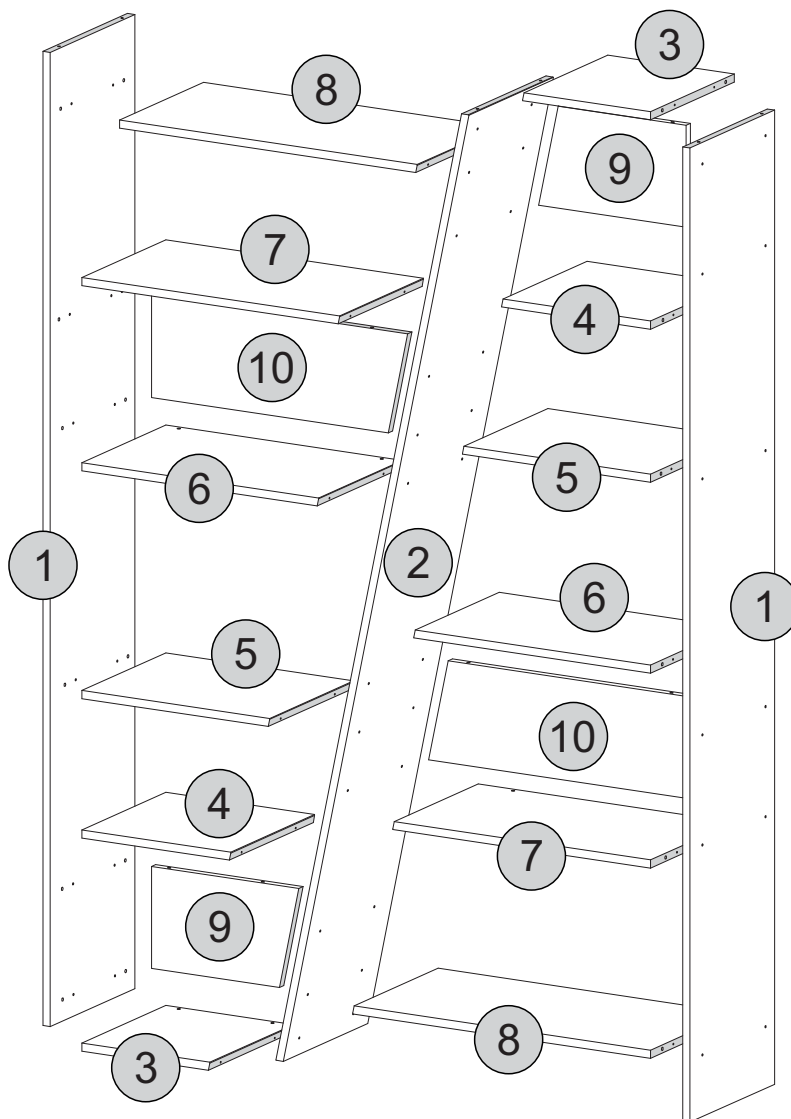

TOOLS REQUIRED

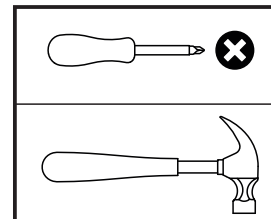





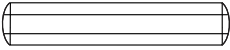
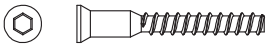

PARTS LIST

Please Note:
The below parts have all been stamped with the part number to help identify them during assembly.

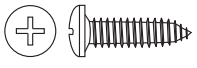
Part Number	Part Code	Part Description	Quantity	Carton
1	S300-306-040-AY1-01	Side Panel	2	2/2
2	S300-306-040-AY1-02	Centre Panel	1	2/2
3	S300-306-040-AY1-03	Shelf A	2	1/2
4	S300-306-040-AY1-04	Shelf B	2	1/2
5	S300-306-040-AY1-05	Shelf C	2	1/2
6	S300-306-040-AY1-06	Shelf D	2	1/2
7	S300-306-040-AY1-07	Shelf E	2	1/2
8	S300-306-040-AY1-08	Shelf F	2	1/2
9	S300-306-040-AY1-09	Small Back Panel	2	1/2
10	S300-306-040-AY1-10	Large Back Panel	2	1/2

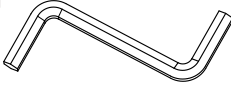
FITTINGS LIST

<p>A</p>  <p>2/+ Dowel Ø6,0 x 30mm (40x)</p>	<p>B</p>  <p>2/+ Pan Head Screw Ø5 x 35mm (48x)</p>	<p>C</p>  <p>1/+ Plastic Foot 5X10mm (6x)</p>	<p>D</p>  <p>1/+ Flat Head Screw Ø4 x 14mm (1x)</p>
<p>E</p>  <p>1/+ Washer (2x)</p>	<p>F</p>  <p>Allen Key (1x)</p>	<p>G</p>  <p>Strap (1x)</p>	<p>H</p>  <p>Glue (2x)</p>

STEP 1

PARTS REQUIRED

3 - SHELF A x2

HARDWARE REQUIRED

A  04

H  01

TOOLS REQUIRED

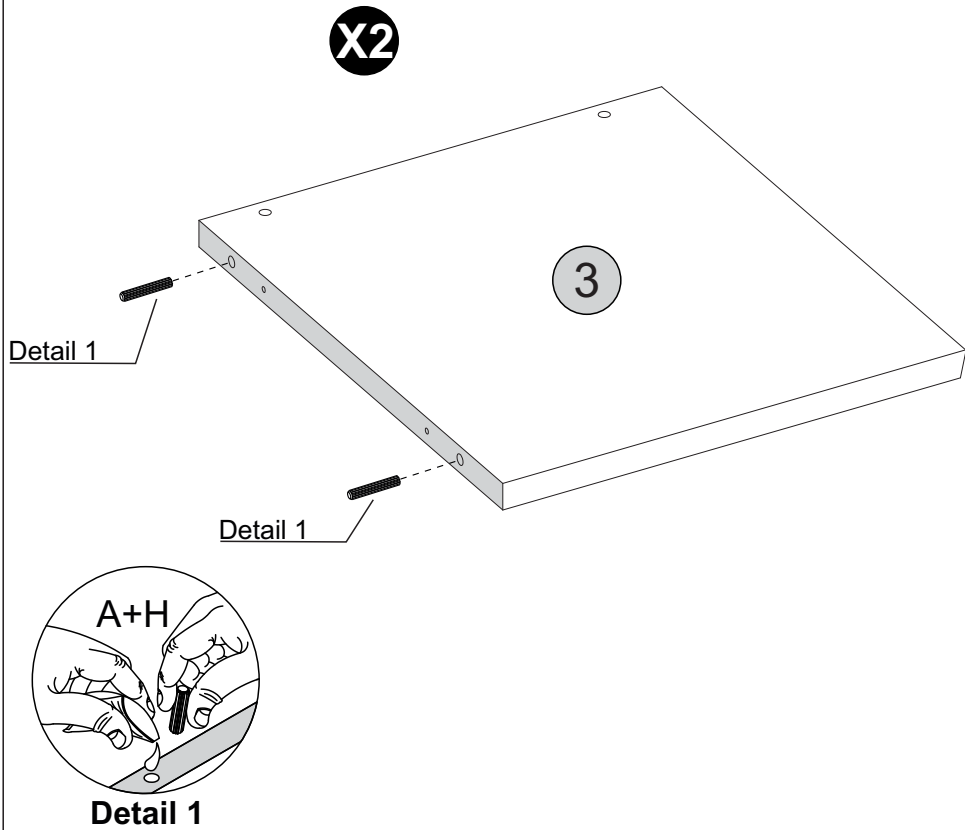
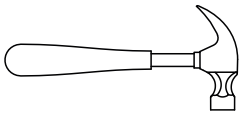

STEP 2

PARTS REQUIRED

4 - SHELF B x2

HARDWARE REQUIRED

A  04

H  01

TOOLS REQUIRED

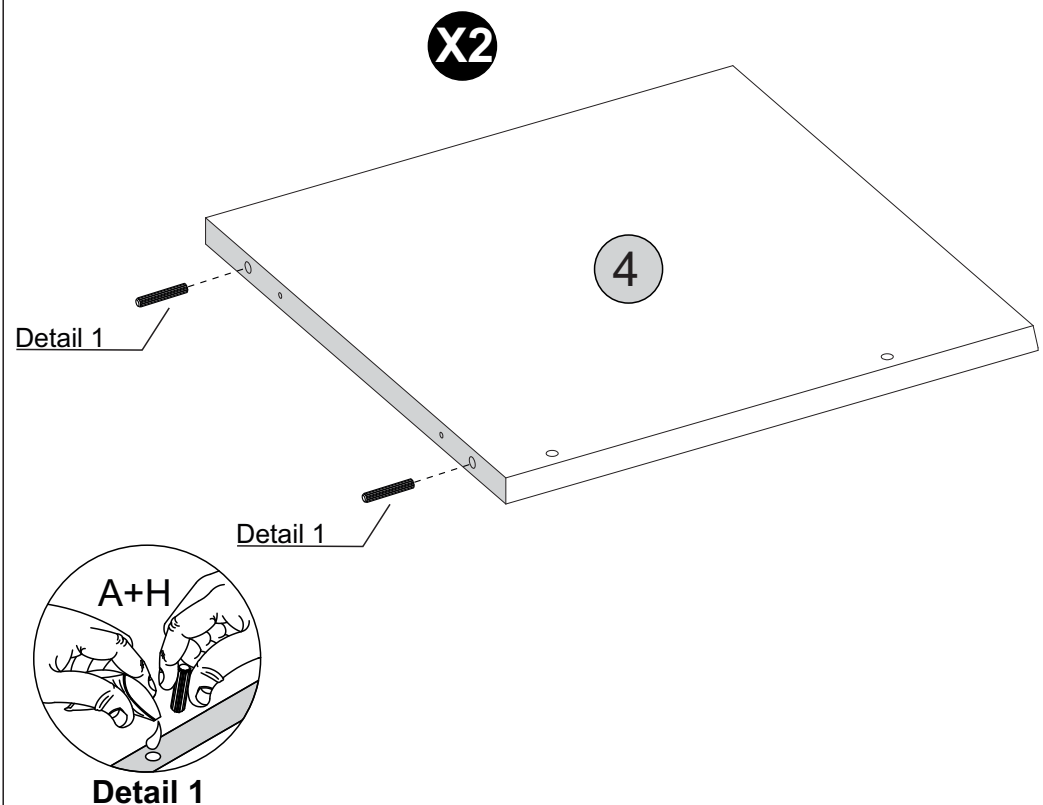
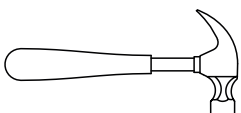

STEP 3

PARTS REQUIRED

5 - SHELF C x2

HARDWARE REQUIRED

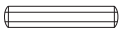
A  04

H  01

TOOLS REQUIRED

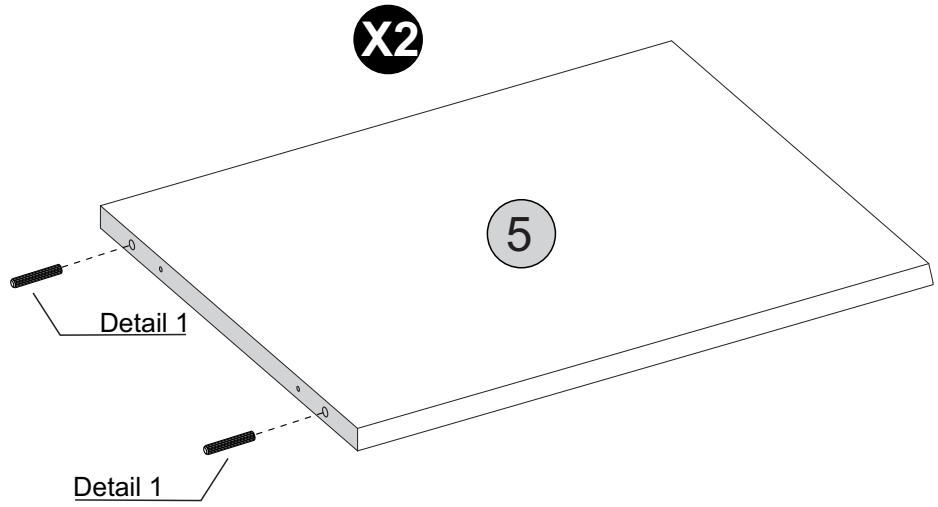
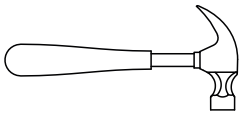

Detail 1

STEP 4

PARTS REQUIRED

6 - SHELF D x2

HARDWARE REQUIRED

A  04

H  01

TOOLS REQUIRED

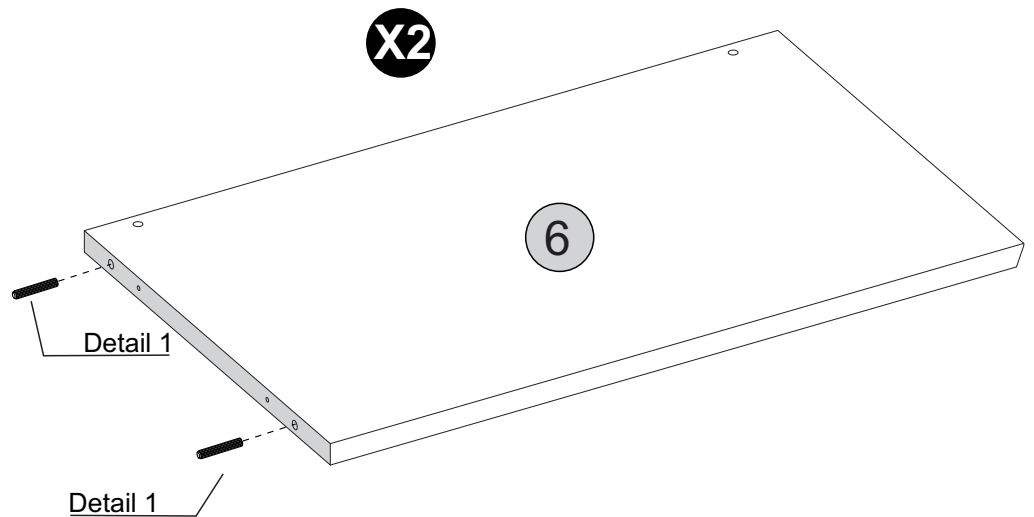
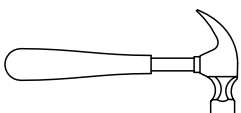

Detail 1

STEP 5

PARTS REQUIRED

7 - SHELF E x2

HARDWARE REQUIRED

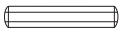
A  04

H  01

TOOLS REQUIRED

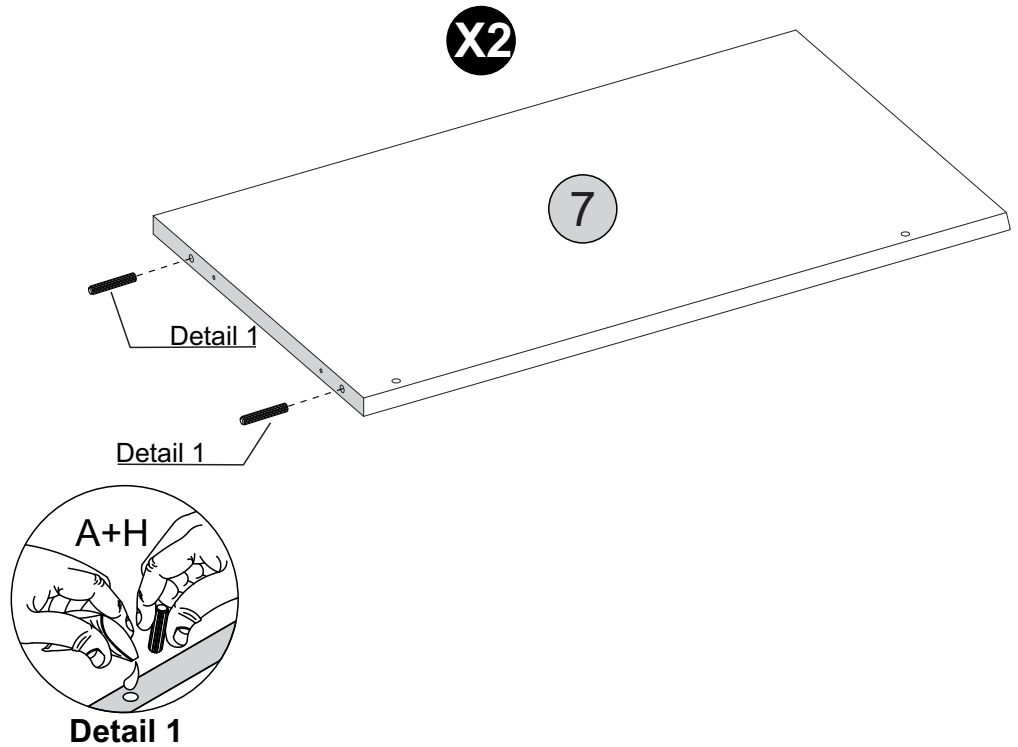
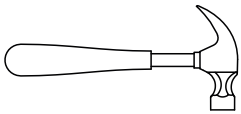

STEP 6

PARTS REQUIRED

8 - SHELF F x2

HARDWARE REQUIRED

A  04

H  01

TOOLS REQUIRED

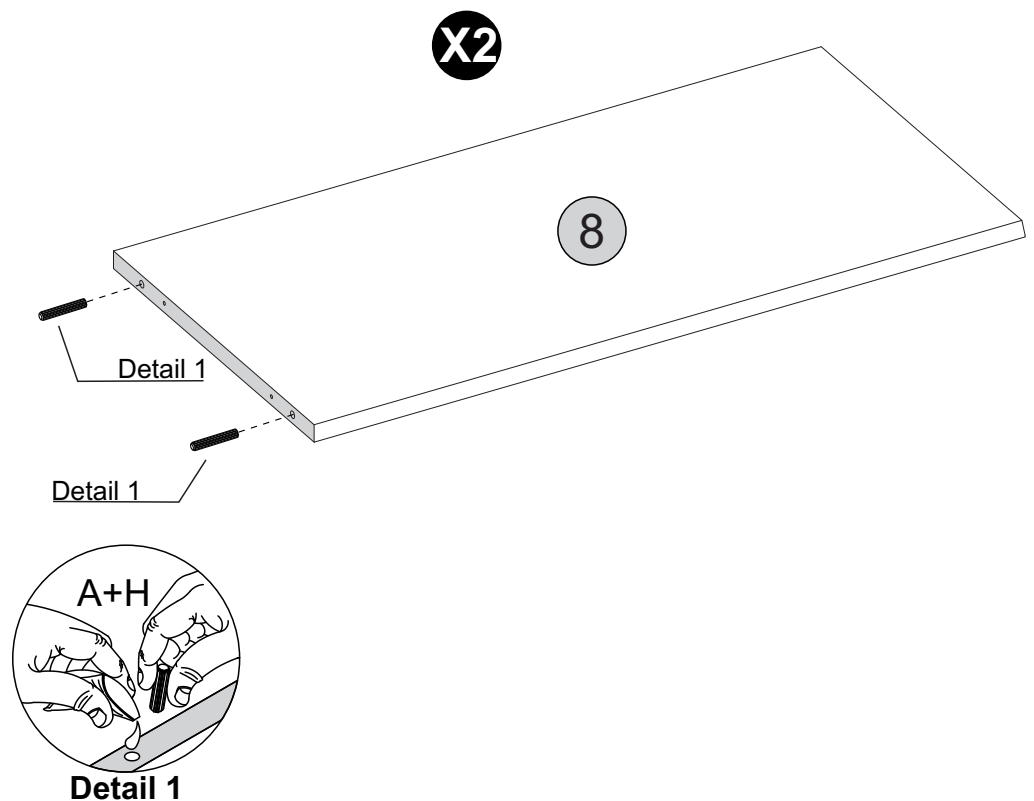
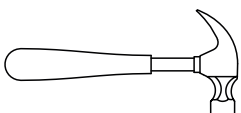

STEP 7

PARTS REQUIRED

9 - SMALL BACK PANEL x2

HARDWARE REQUIRED

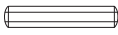
A  08

H  01

TOOLS REQUIRED

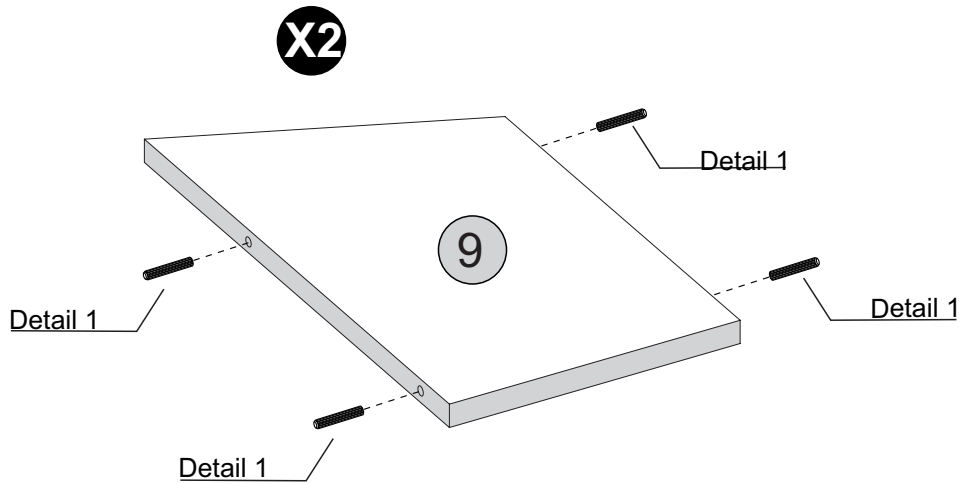
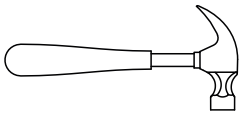

Detail 1

STEP 8

PARTS REQUIRED

10 - LARGE BACK PANEL x2

HARDWARE REQUIRED

A  08

H  01

TOOLS REQUIRED

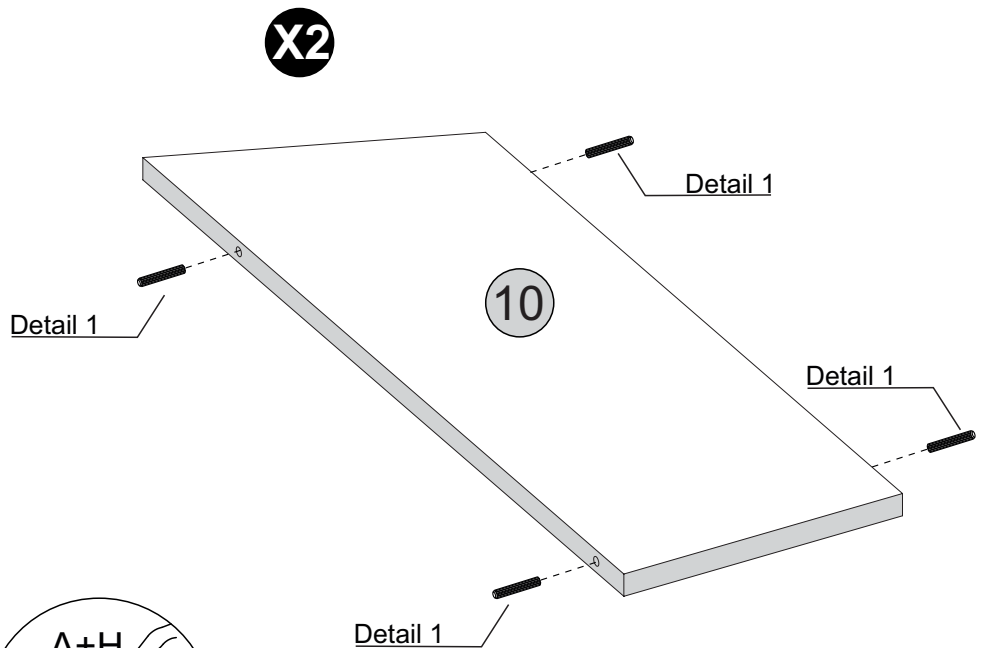
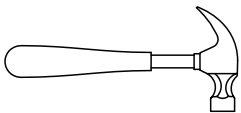



Detail 1

STEP 9

PARTS REQUIRED

2 - CENTRE PANEL	x1
3 - SHELF A	x1
8 - SHELF F	x1

HARDWARE REQUIRED

B		04
H		01

TOOLS REQUIRED

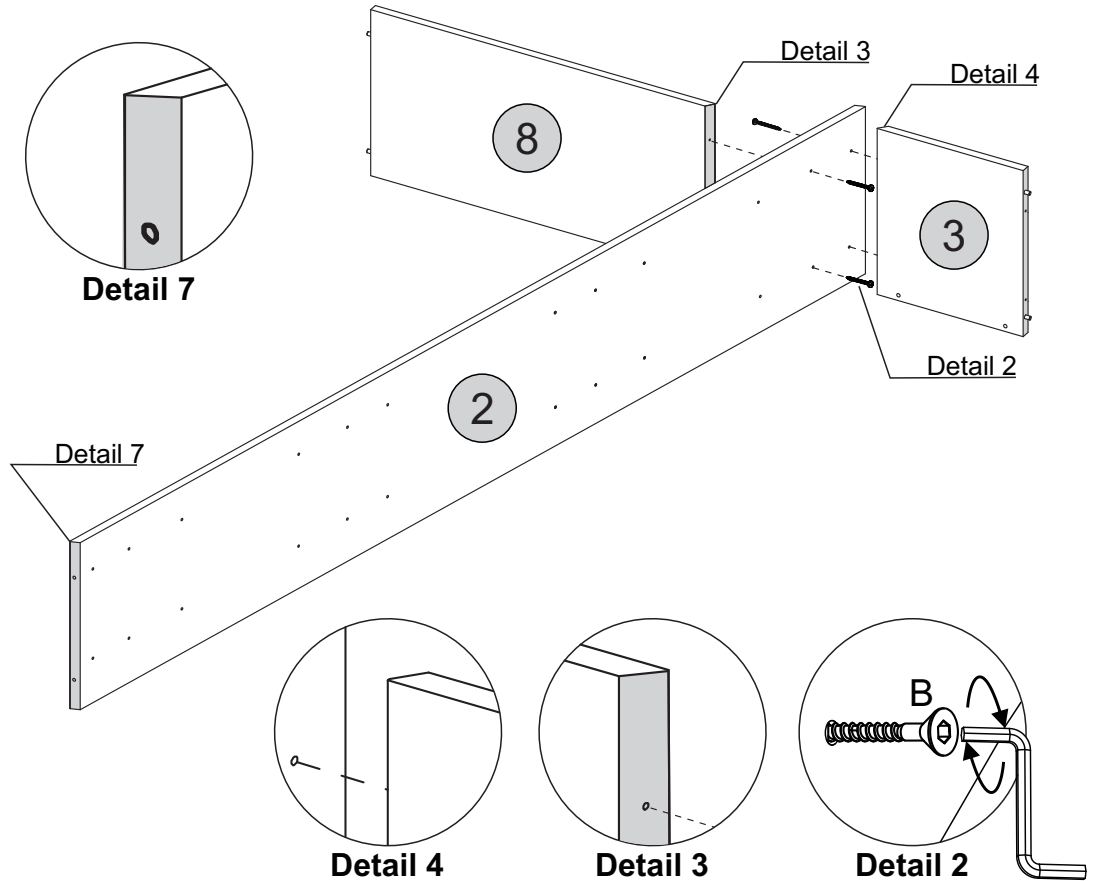

STEP 10

PARTS REQUIRED

9 - SMALL BACK PANEL	x1
----------------------	----

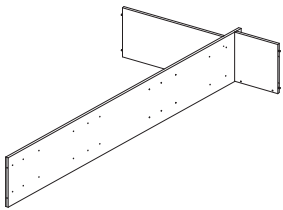

HARDWARE REQUIRED

H		01
---	---	----

TOOLS REQUIRED

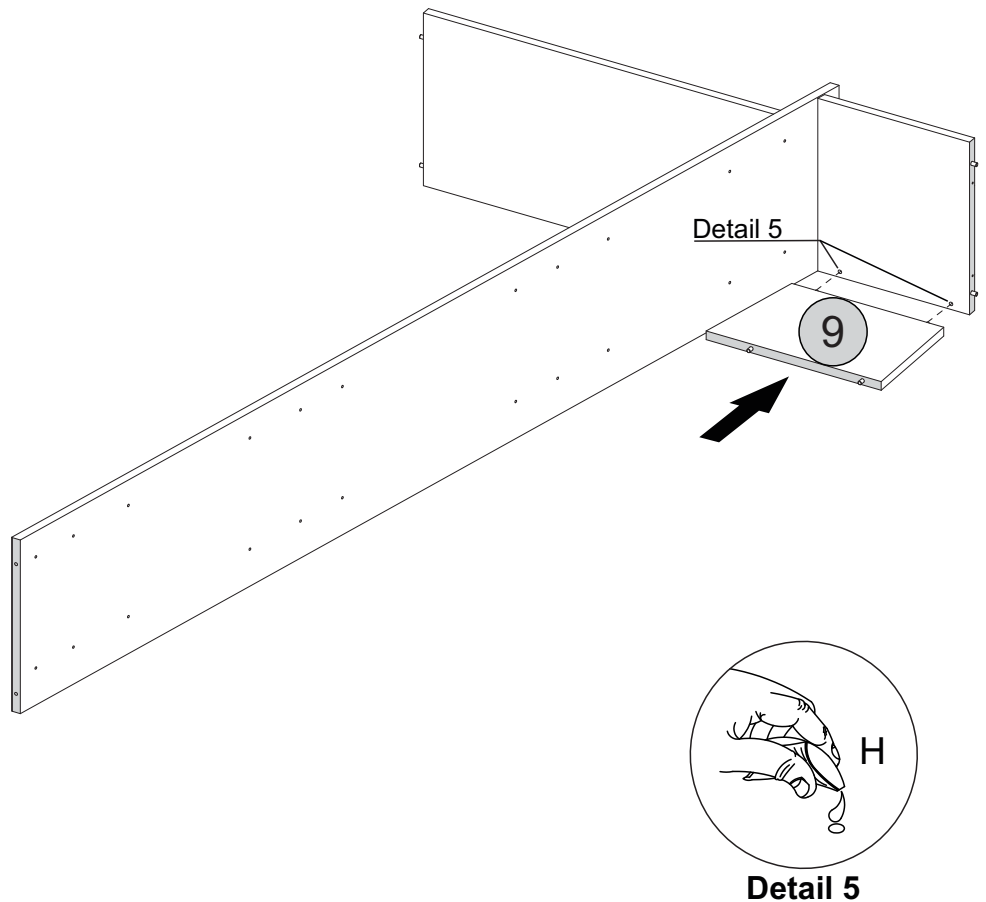

STEP 11

PARTS REQUIRED

4 - SHELF B x1

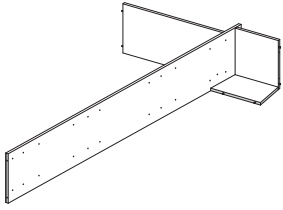

HARDWARE REQUIRED

B  02

H  01

TOOLS REQUIRED

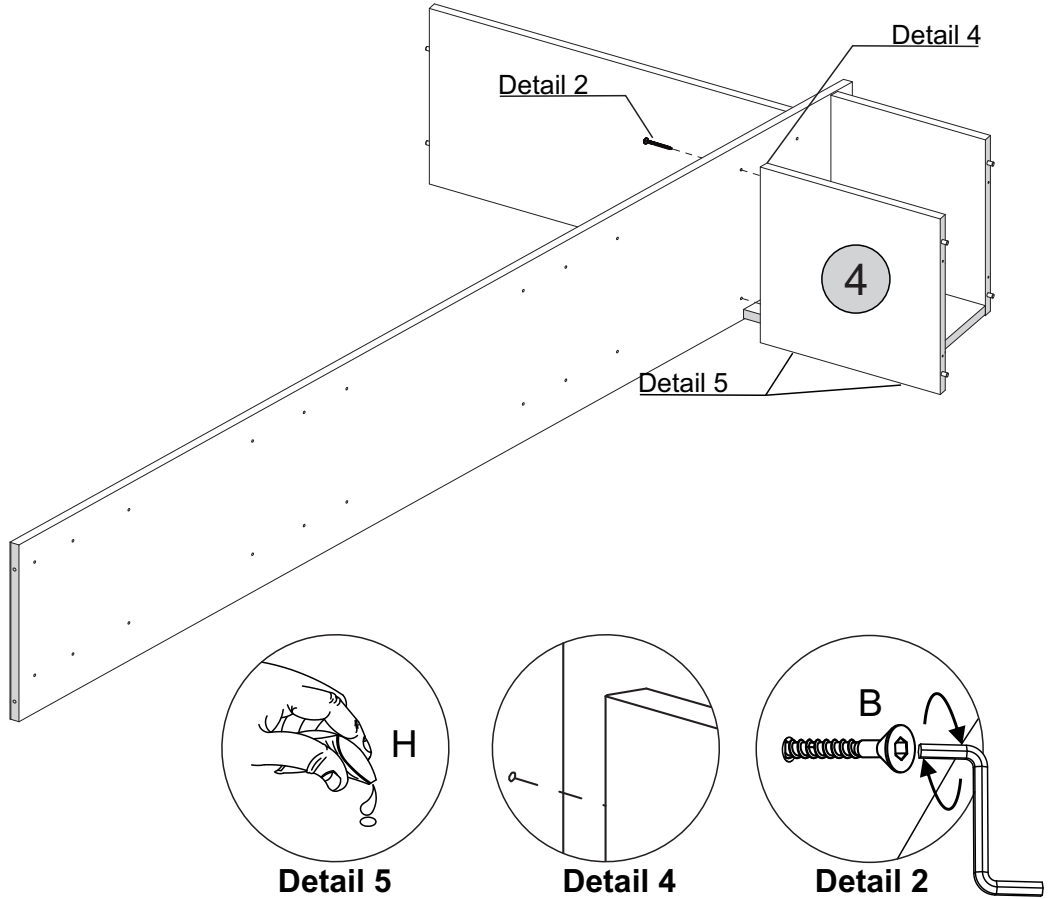

Detail 5

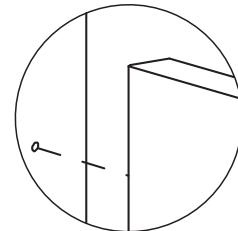

Detail 4

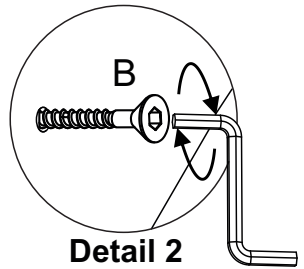

Detail 2

STEP 12

PARTS REQUIRED

5 - SHELF C x1

7 - SHELF E x1

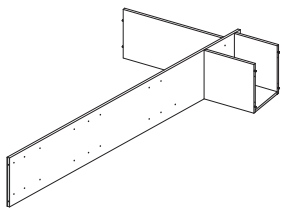

B  04

TOOLS REQUIRED

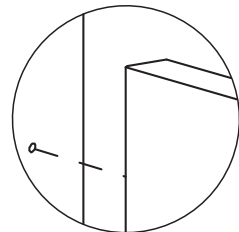
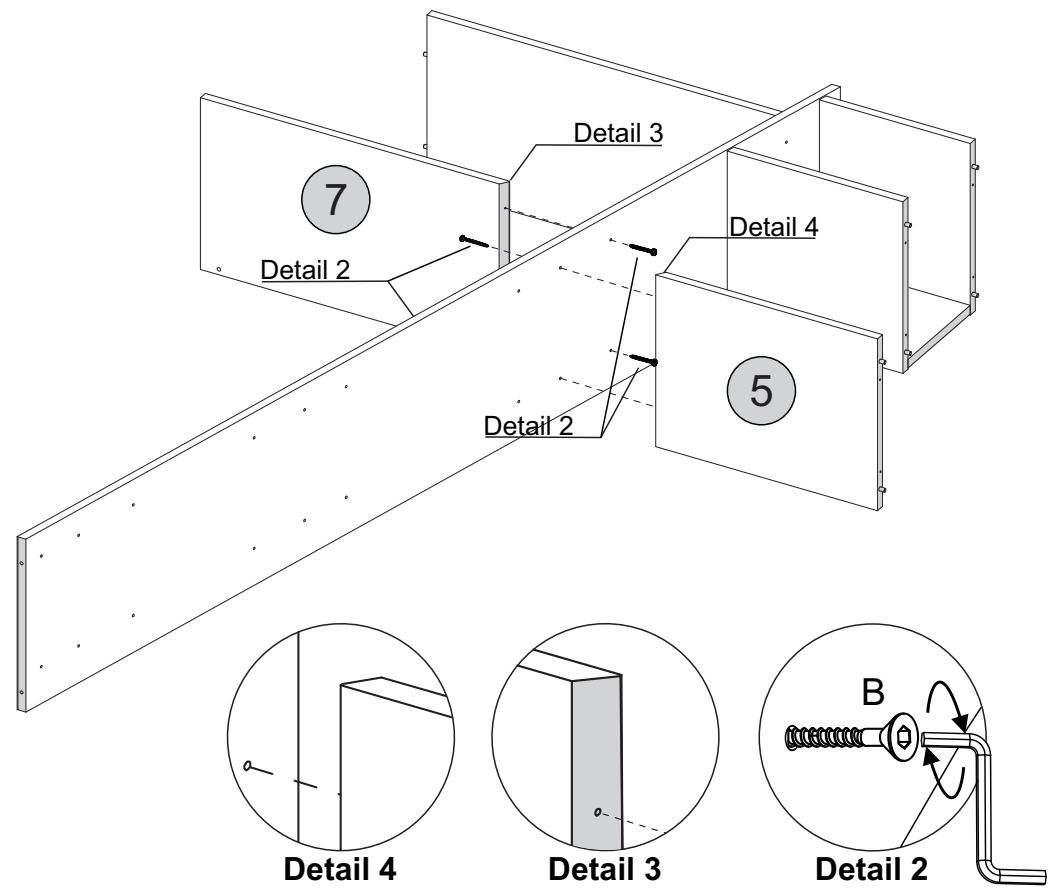

Detail 4

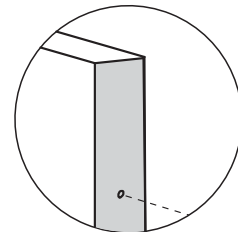

Detail 3

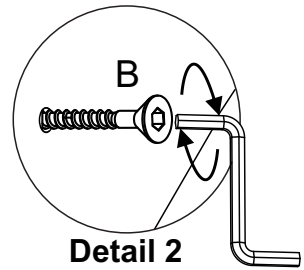

Detail 2

STEP 13

PARTS REQUIRED

10 - LARGE BACK PANEL x1

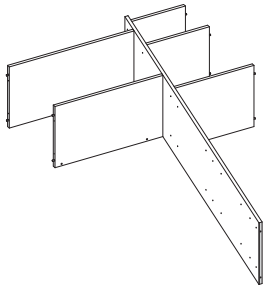

HARDWARE REQUIRED

H  01

TOOLS REQUIRED

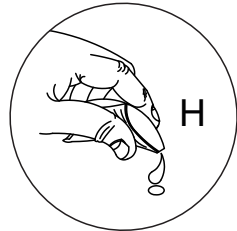

Detail 5

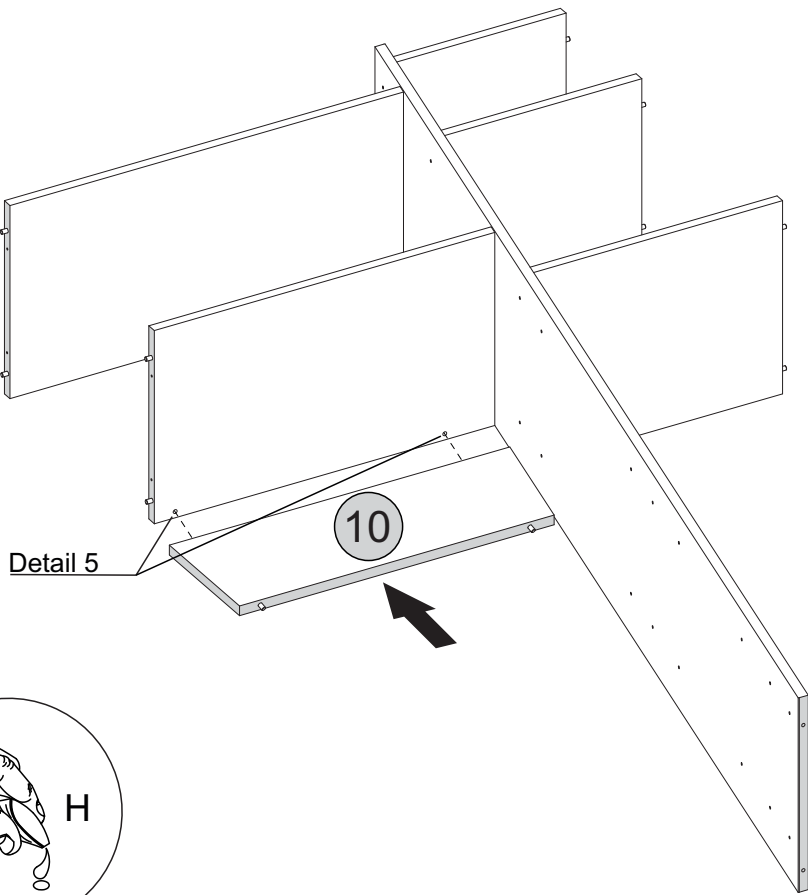

STEP 14

PARTS REQUIRED

6 - SHELF D x1

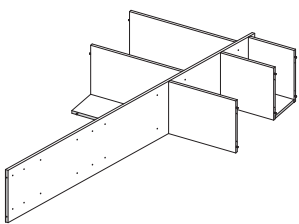

HARDWARE REQUIRED

B   02

H  01

TOOLS REQUIRED

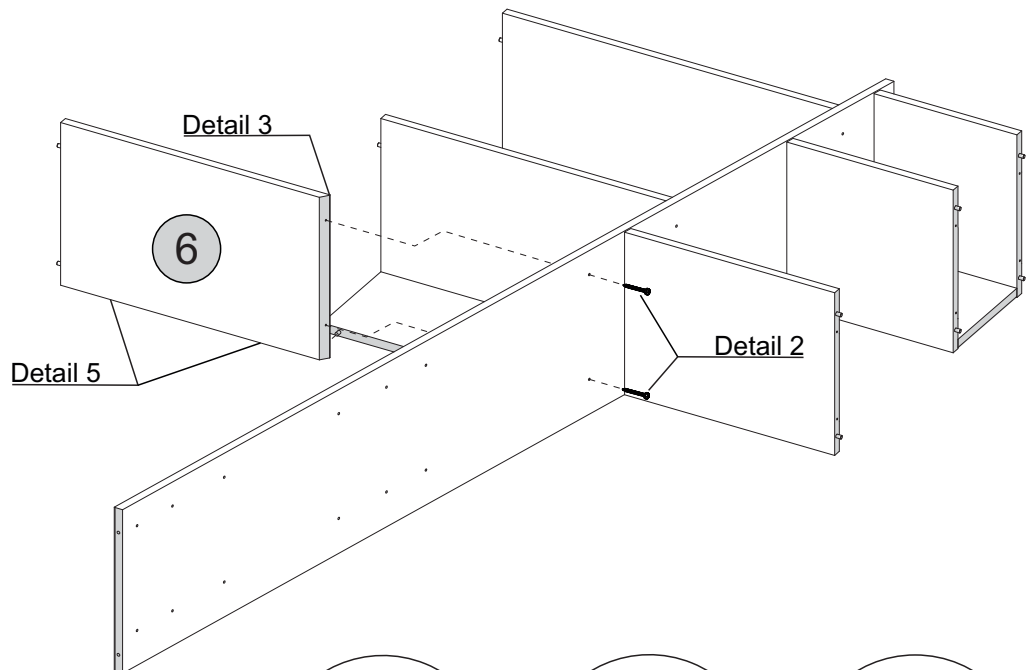
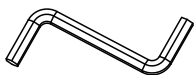

Detail 5

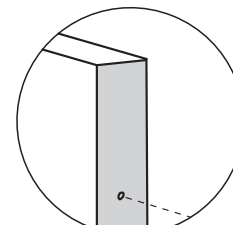

Detail 3

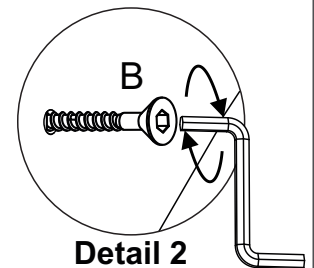

Detail 2

STEP 15

PARTS REQUIRED

5 - SHELF C x1

6 - SHELF D x1

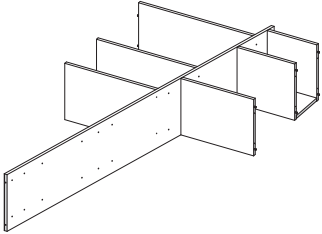

HARDWARE REQUIRED

B  04

TOOLS REQUIRED

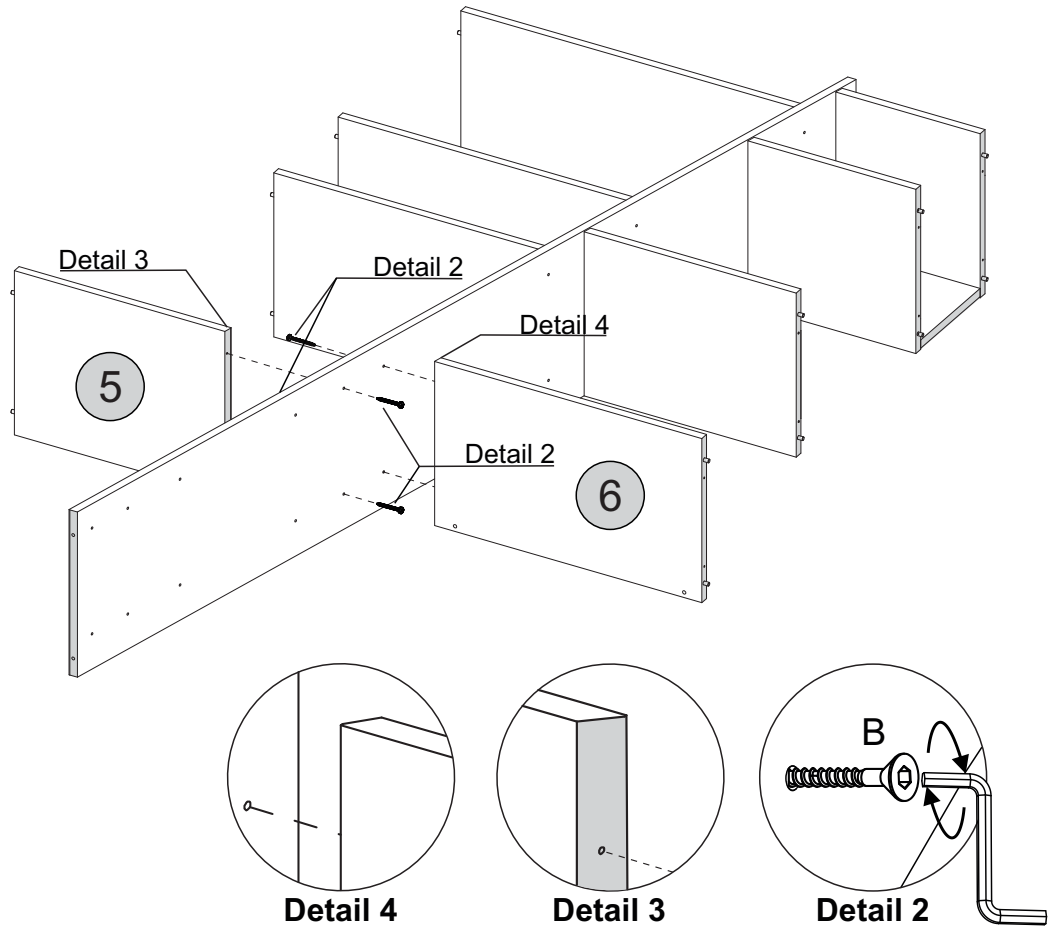
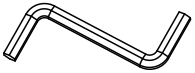

STEP 16

PARTS REQUIRED

10 - LARGE BACK PANEL x1

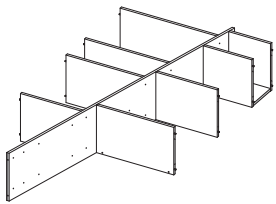

HARDWARE REQUIRED

H  01

TOOLS REQUIRED

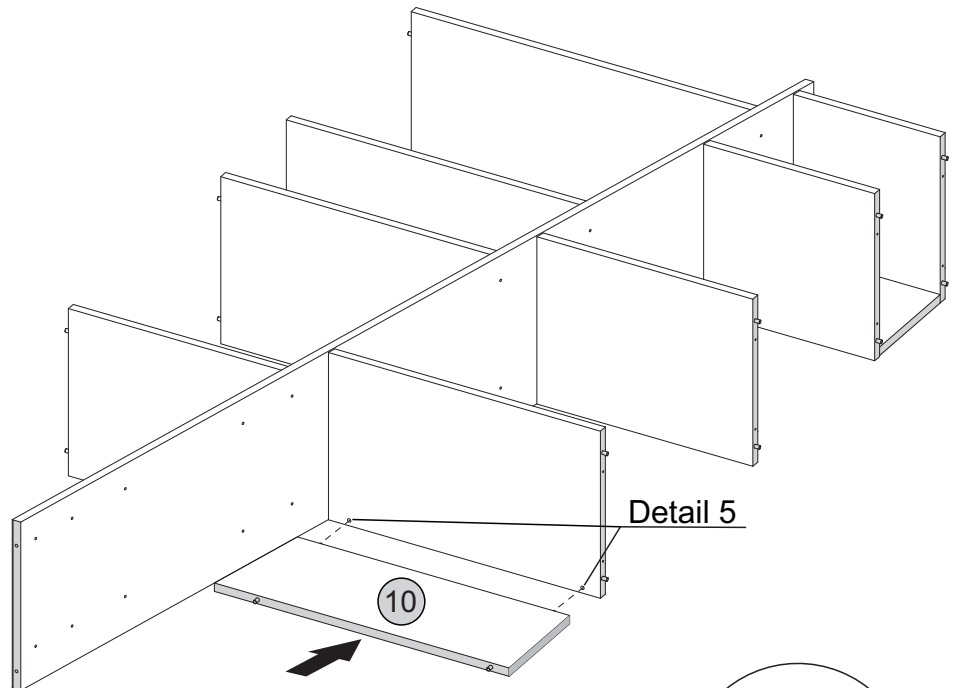

STEP 17

PARTS REQUIRED

7 - SHELF E x1

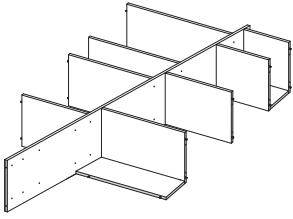

HARDWARE REQUIRED

B 02

H 01

TOOLS REQUIRED

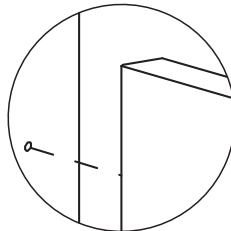
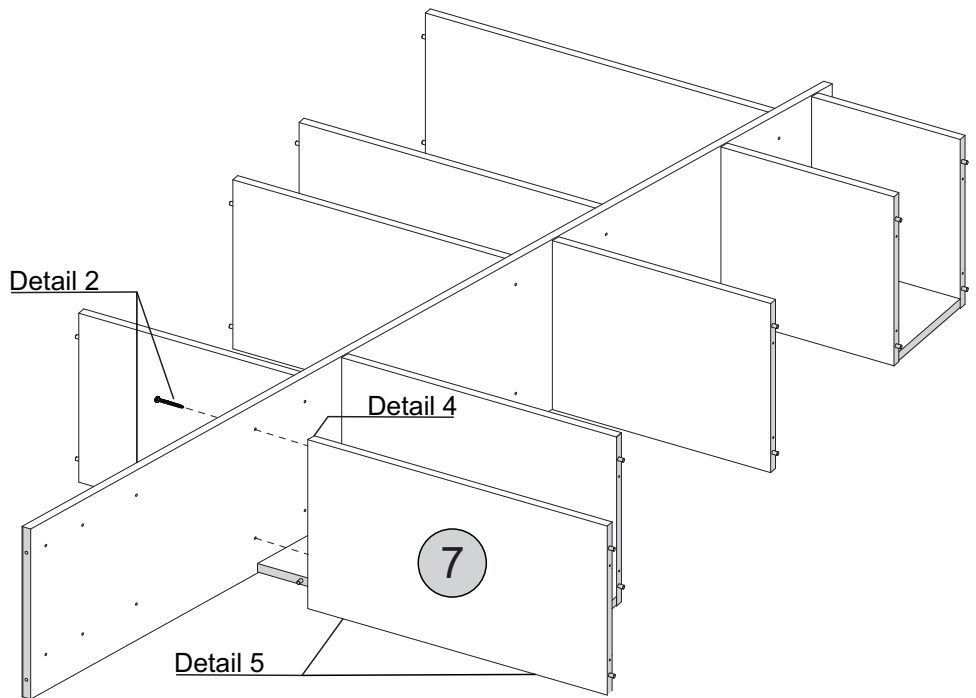

Detail 4

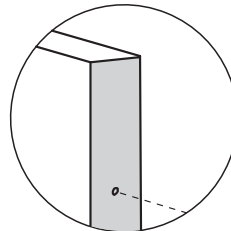

Detail 3

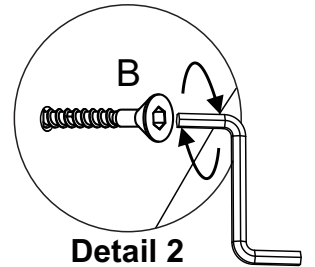

Detail 2

STEP 18

PARTS REQUIRED

4 - SHELF B x1

8 - SHELF F x1

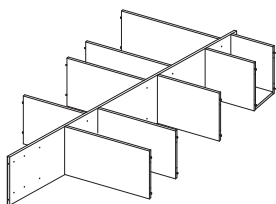

HARDWARE REQUIRED

B 04

TOOLS REQUIRED

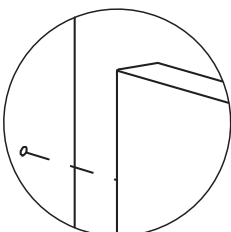
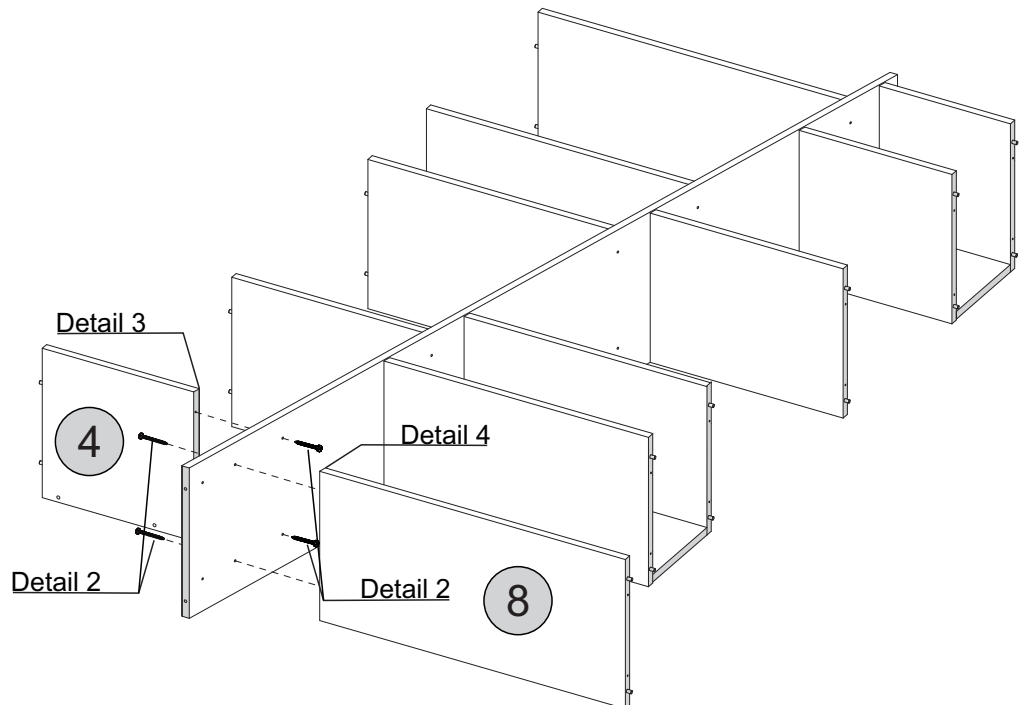

Detail 4

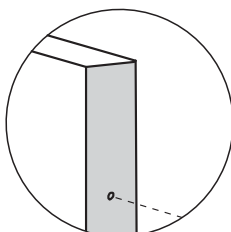

Detail 3

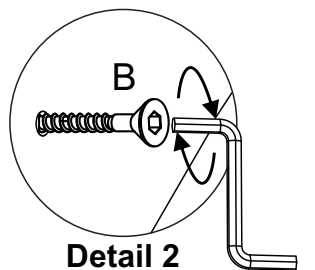

Detail 2

STEP 19

PARTS REQUIRED

9 - SMALL BACK PANEL x1

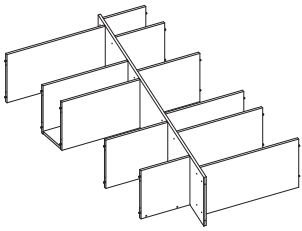

HARDWARE REQUIRED

H  01

TOOLS REQUIRED



Detail 5

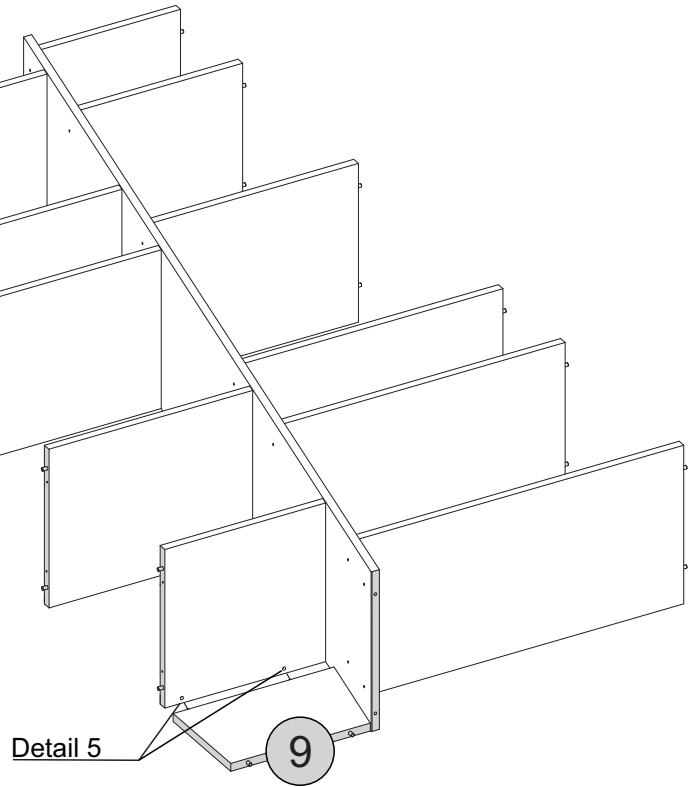

STEP 20

PARTS REQUIRED

3 - SHELF A x1

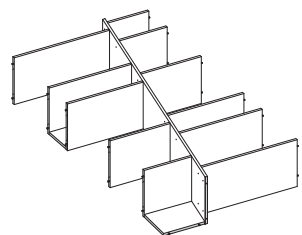

HARDWARE REQUIRED

B  02

H  01

TOOLS REQUIRED

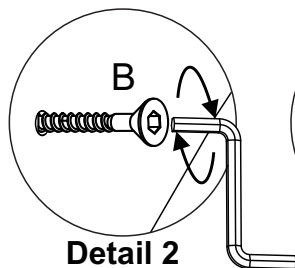

Detail 2



Detail 5

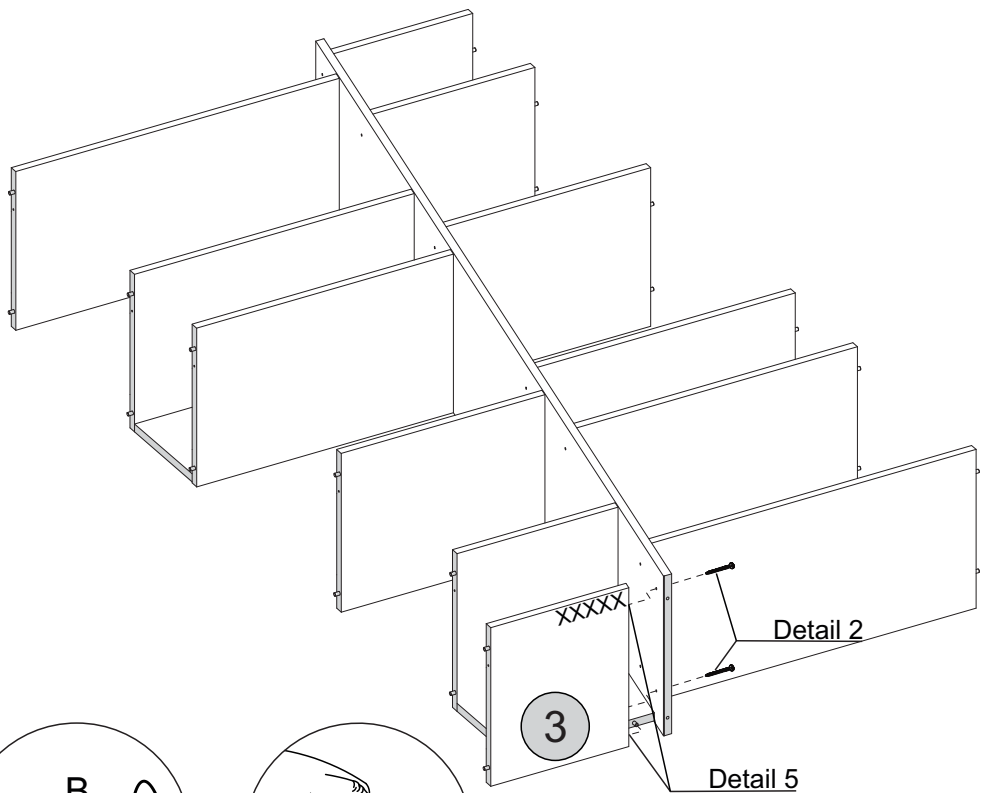

STEP 21

PARTS REQUIRED

1 - SIDE PANEL x1

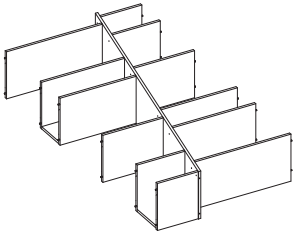

HARDWARE REQUIRED

B  12

H  01

TOOLS REQUIRED

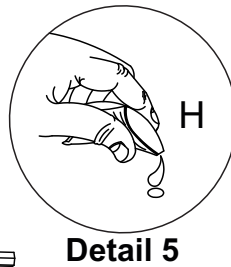
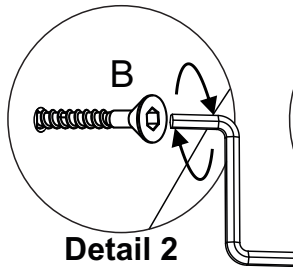
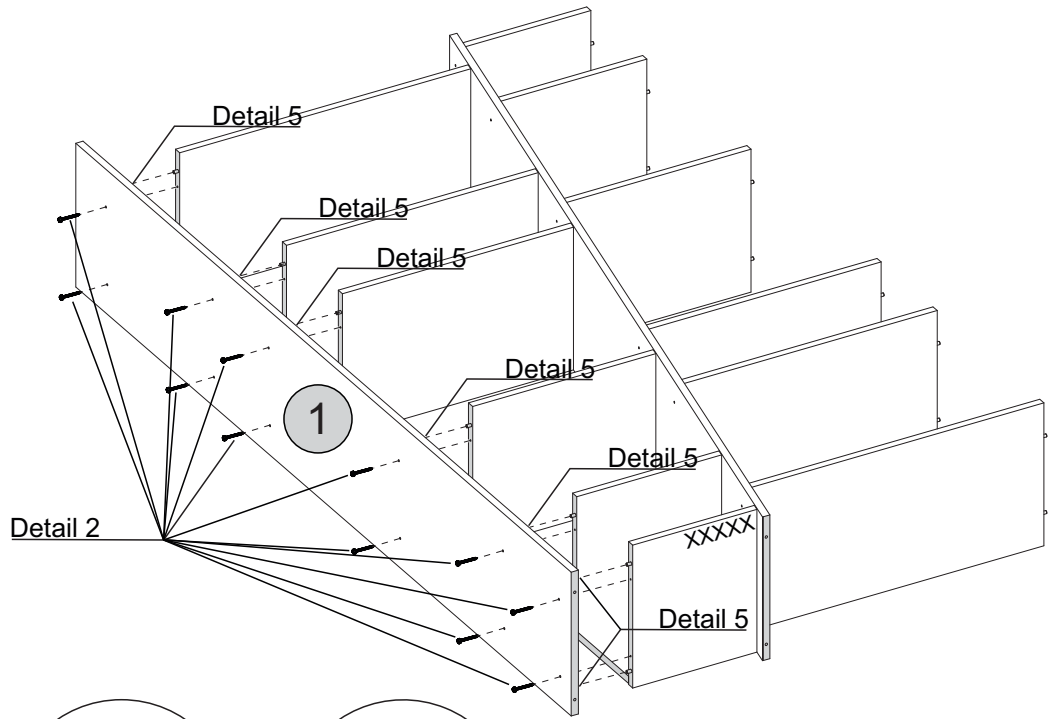
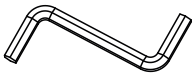

STEP 22

PARTS REQUIRED

1 - SIDE PANEL x1

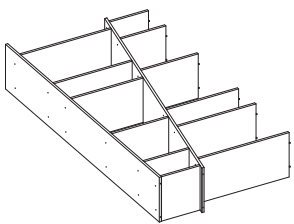

HARDWARE REQUIRED

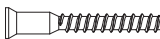
B  12

H  01

TOOLS REQUIRED

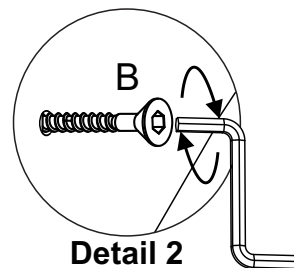
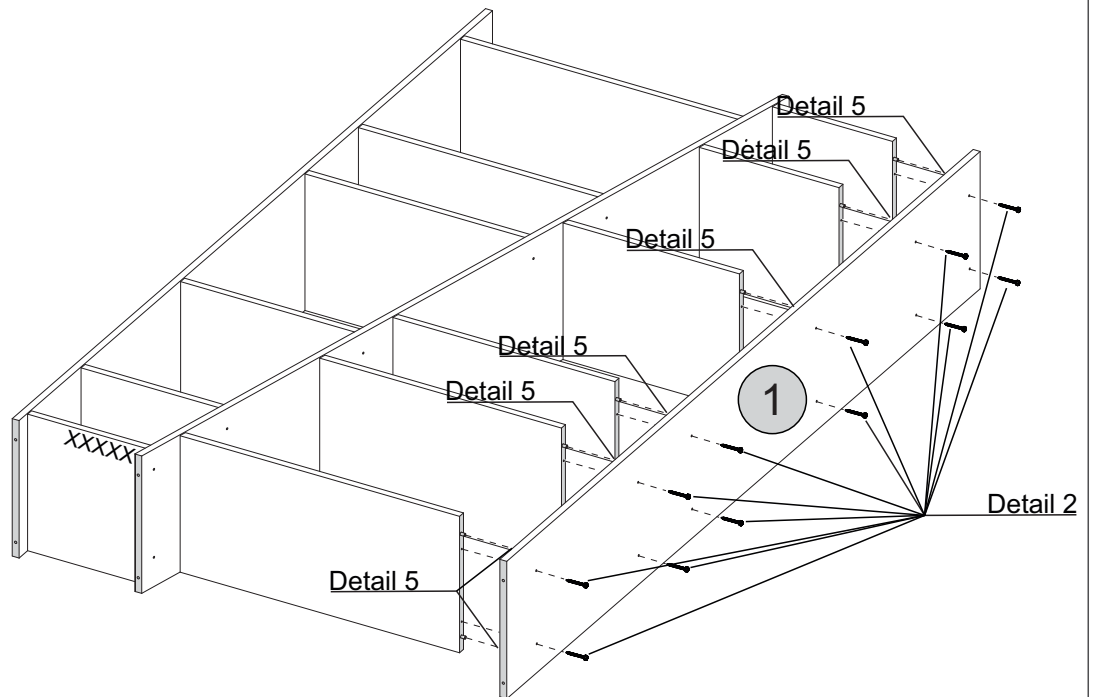

STEP 23

SEC/SH/10/21/AY1

PARTS REQUIRED

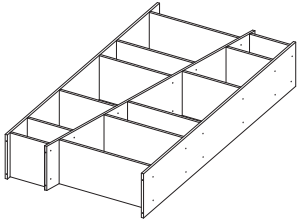

HARDWARE REQUIRED

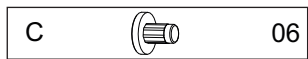

TOOLS REQUIRED

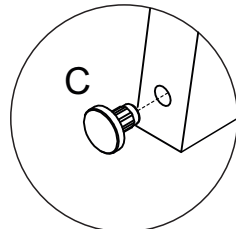
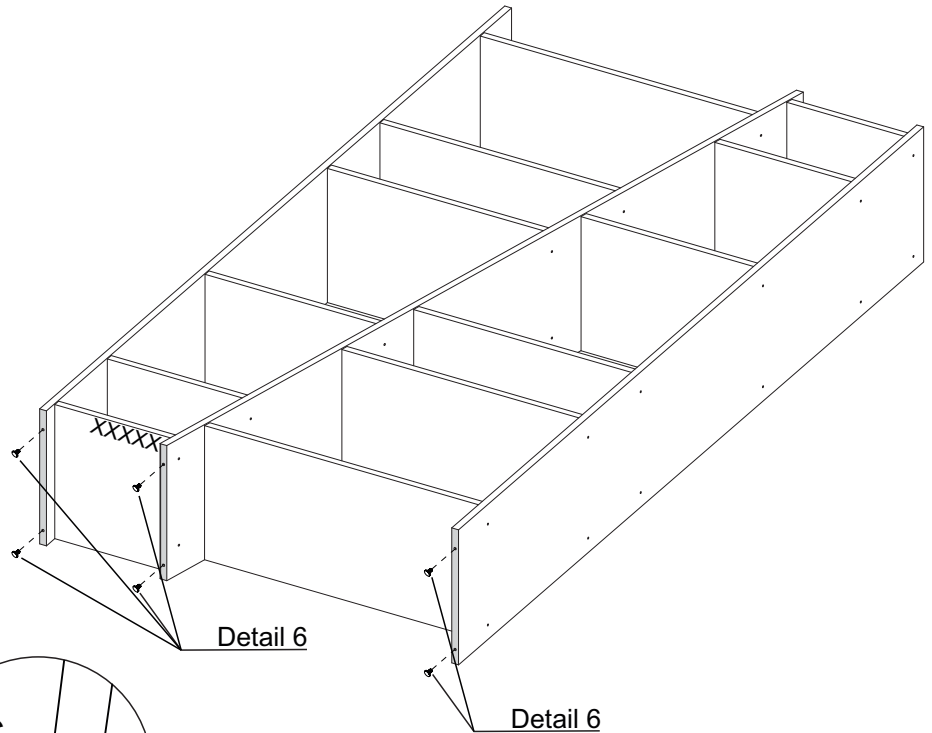
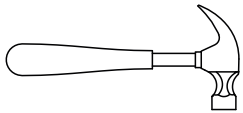

Detail 6

STEP 24

PARTS REQUIRED

HARDWARE REQUIRED

TOOLS REQUIRED

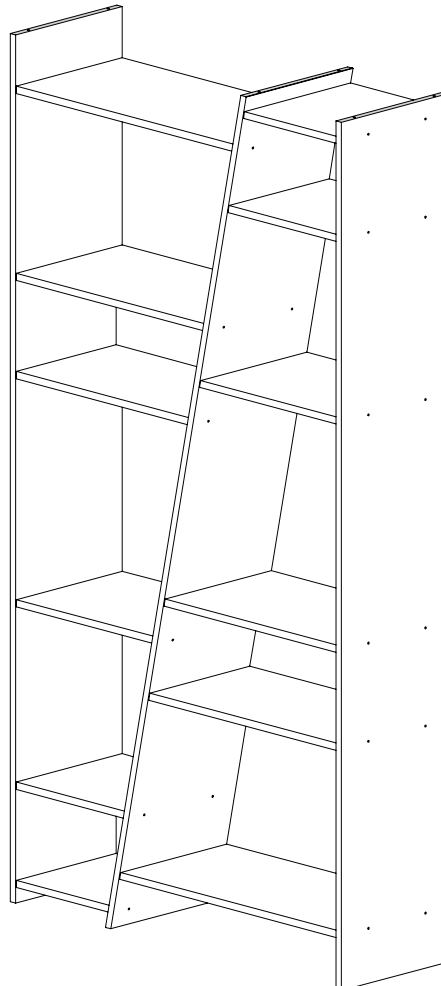

WARNING

Serious or fatal injuries can occur from furniture tipping over. To prevent the furniture from tipping over we recommend that it is permanently fixed to the wall.

Wall fixings are not supplied with this product as different wall materials require different types of fixing devices.

Please make sure you use fixings suitable for the walls in your home.

