

LEON 3+2 DRAWER CHEST ASSEMBLY INSTRUCTIONS

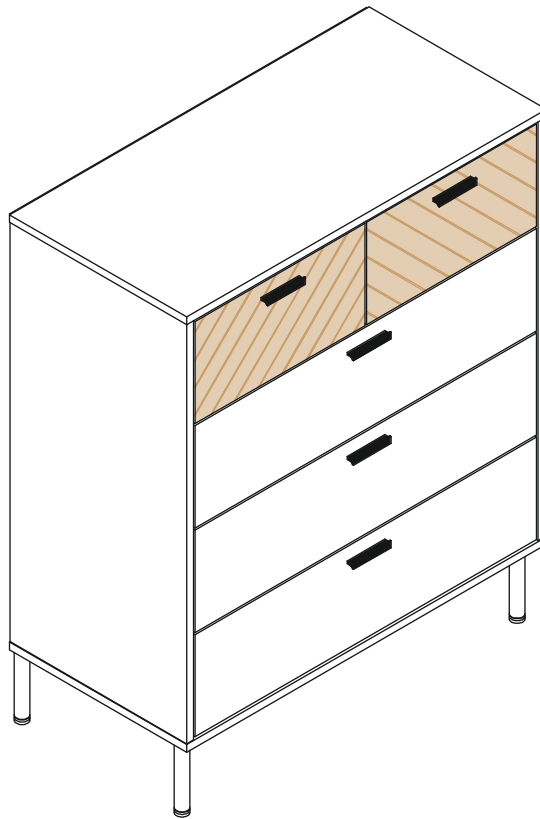

**FOR DOMESTIC USE ONLY
IMPORTANT**

PLEASE READ BEFORE YOU CONTINUE FURTHER

THE PRODUCT YOU HAVE PURCHASED WILL GIVE YOU MANY YEARS OF SERVICE IF YOU FOLLOW THE GUIDELINES FOR ITS SAFE ASSEMBLY AND PERIODIC MAINTENANCE AND CLEANING.

ASSEMBLE ON A SOFT CLEAN SURFACE.

DO NOT USE ANY TOOLS OTHER THAN THOSE SHOWN.

ANY SPANNERS OR ALLEN KEYS REQUIRED ARE INCLUDED WITH THE FITTING KIT.

DO NOT FOR ANY REASON USE A POWER TOOL TO ASSEMBLE THIS PRODUCT. ITS USE WILL INVALIDATE ANY CLAIM YOU MAY HAVE AND COULD MAKE THIS PRODUCT UNSAFE.

DEPENDING ON THE AMOUNT OF USE THIS PRODUCT RECEIVES, IT MAY BE NECESSARY TO TIGHTEN UP THE FIXINGS FROM TIME TO TIME. THIS IS COMPLETELY NORMAL FOR ANY FLAT PACK FURNITURE. DO NOT OVERTIGHTEN FIXINGS.

FOR CLEANING, YOU MAY USE A DAMP CLOTH (NOT WET). DO NOT USE POLISH, DETERGENT OR CHEMICAL CLEANERS.



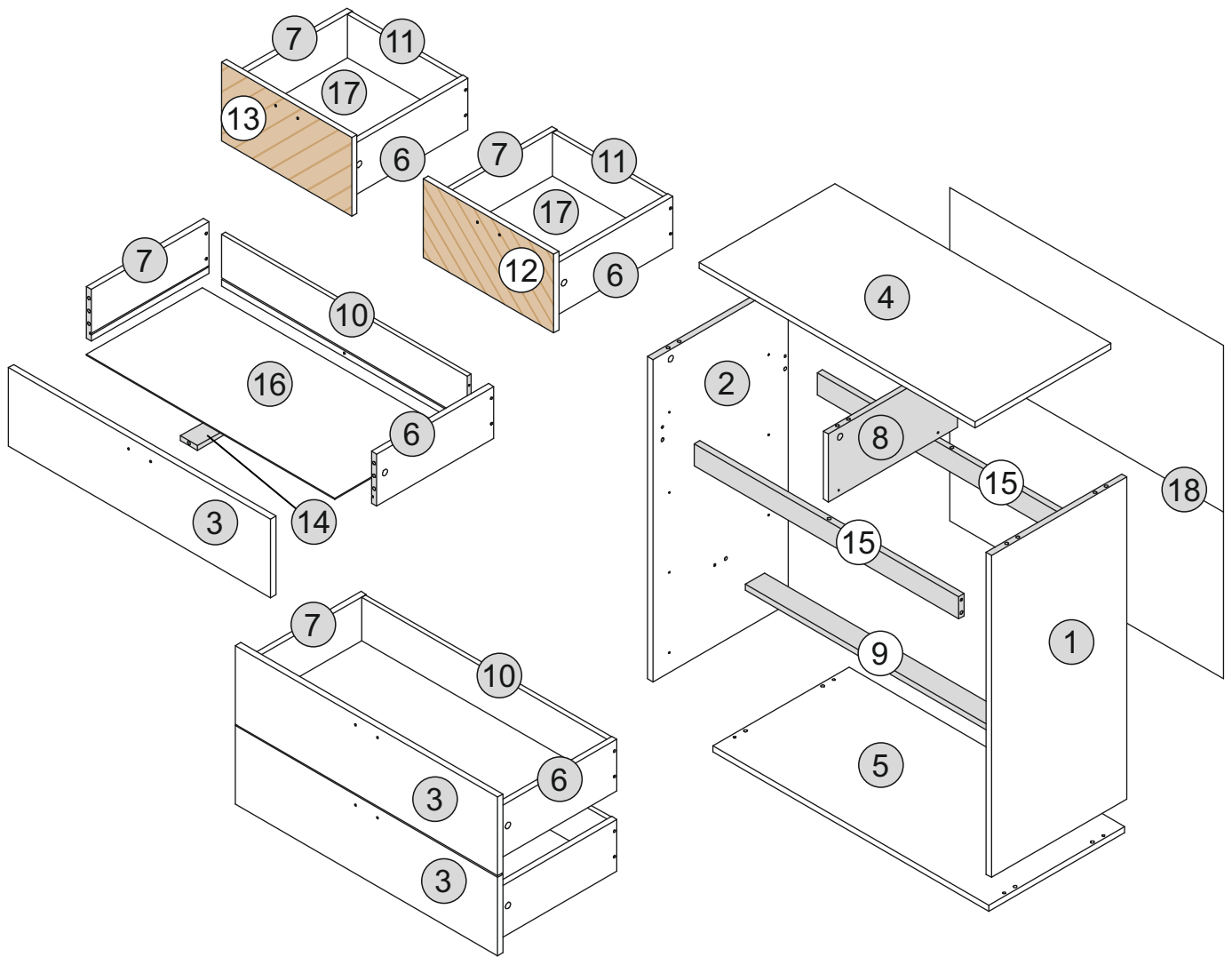









THIS SURFACE OF THIS ITEM IS NOT HEAT RESISTANT. ALWAYS USE A PLACE MAT UNDER HOT OR COLD ITEMS TO PREVENT MARKING.



PART LIST

Part Number	Part Code	Part Description	Quantity	Carton
1	S100-102-179-ZF1-01	Right Side Panel	1	2/2
2	S100-102-179-ZF1-02	Left Side Panel	1	2/2
3	S100-102-179-ZF1-03	Large Drawer Front	3	2/2
4	S100-102-179-ZF1-04	Top Panel	1	2/2
5	S100-102-179-ZF1-05	Bottom Panel	1	2/2
6	S100-102-179-ZF1-06	Right Drawer Side Panel	5	1/2
7	S100-102-179-ZF1-07	Left Drawer Side Panel	5	1/2
8	S100-102-179-ZF1-08	Centre Panel	1	1/2
9	S100-102-179-ZF1-09	Centre Support Panel	1	1/2
10	S100-102-179-ZF1-10	Large Drawer Back Panel	3	1/2
11	S100-102-179-ZF1-11	Small Drawer Back Panel	2	1/2
12	S100-102-179-ZF1-12	Small Drawer Front (R)	1	2/2
13	S100-102-179-ZF1-13	Small Drawer Front (L)	1	2/2
14	S100-102-179-ZF1-14	Drawer Support	3	1/2
15	S100-102-179-ZF1-15	Support Panel	2	1/2
16	S100-102-179-ZF1-16	Large Drawer Base	3	1/2
17	S100-102-179-ZF1-17	Small Drawer Base	2	1/2
18	S100-102-179-ZF1-18	Back Panel	1	1/2

HARDWARE LIST

No	Part Name		Qty	Carton
A	M8x30mm Wooden Dowel		x36	1
B	Minifix Cam Bolt (8032t)		x27	1
C	Minifix Cam Nut (1512)		x24	1
D	M3.5x16mm Screw		x58	1
E	M4x45mm Screw		x4	1
F	M4x38mm Screw		x23	1
G	20mm Handle Screw		x10	1
H	Handle (64mm)		x5	1
I	14" Drawer Slide (VKT 0.9 - Black)		x5	1
J	Nail		x34	1
K	Minifix Cam Nut (1510)		x3	1
L	Iron Leg (150mm) - Black		x4	1
M	Wall Fixing (4x20mm=1pc)		x1	1

TIPS FOR FITTINGS CAM-LOCKS

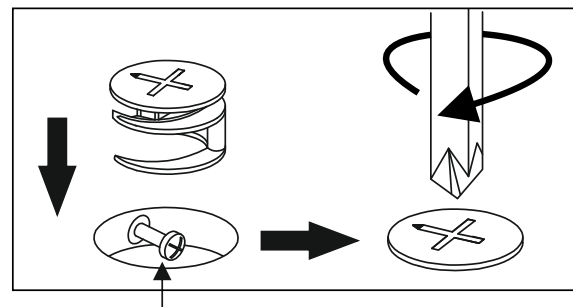
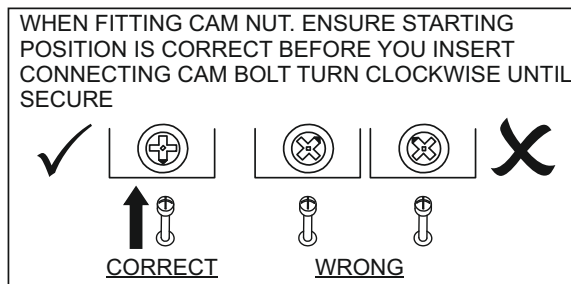

Cam bolt head needs to be in centre

CAMBOLT

Tighten until shoulder is flush with panel. Do not overtighten or undertighten (see example below)

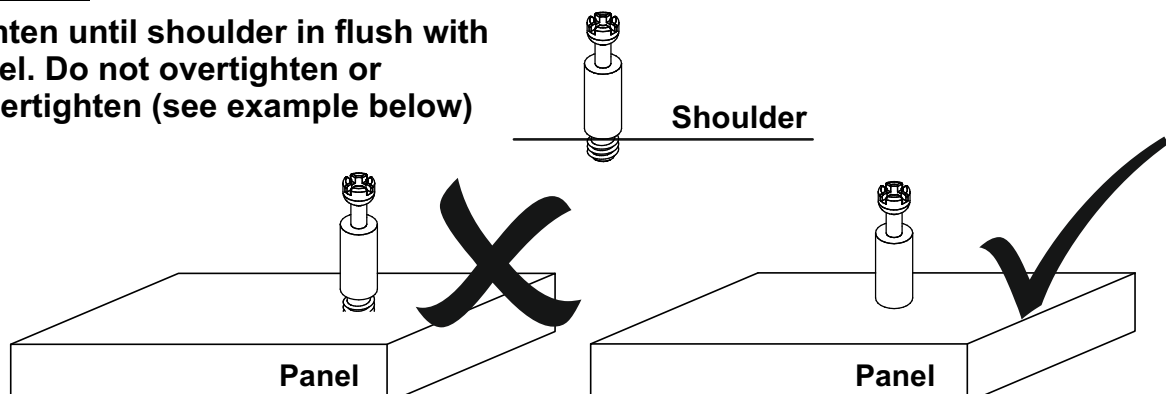

STEP 1

PARTS REQUIRED

1 - RIGHT SIDE PANEL x1

2 - LEFT SIDE PANEL x1

HARDWARE REQUIRED

D  3.5x16mm 16

I  04

TOOLS REQUIRED

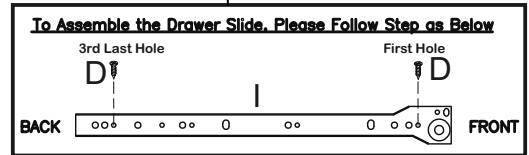
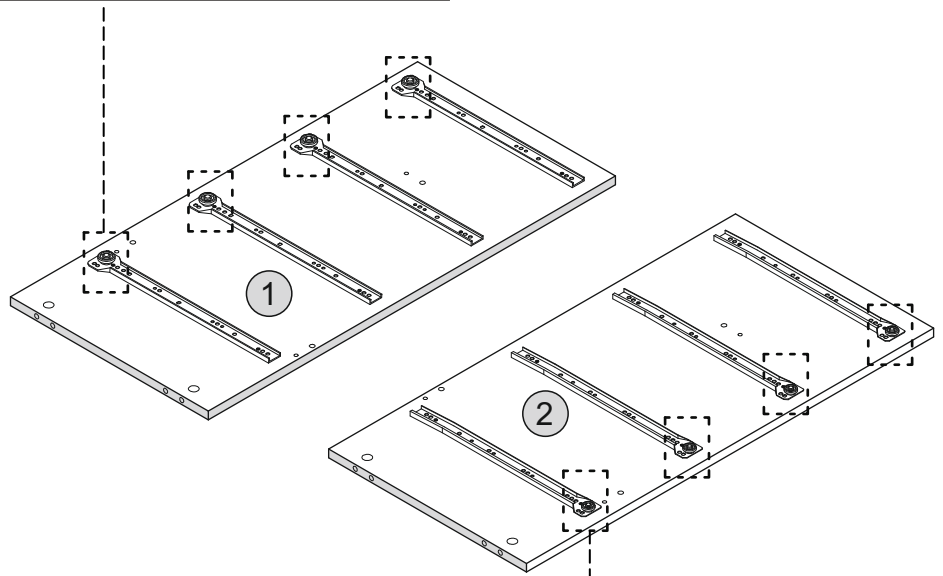
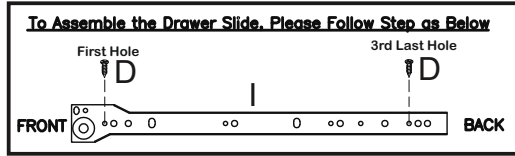
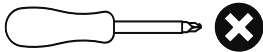

STEP 2

PARTS REQUIRED

1 - RIGHT SIDE PANEL x1

2 - LEFT SIDE PANEL x1

HARDWARE REQUIRED

A  08

B  06

C  04

TOOLS REQUIRED

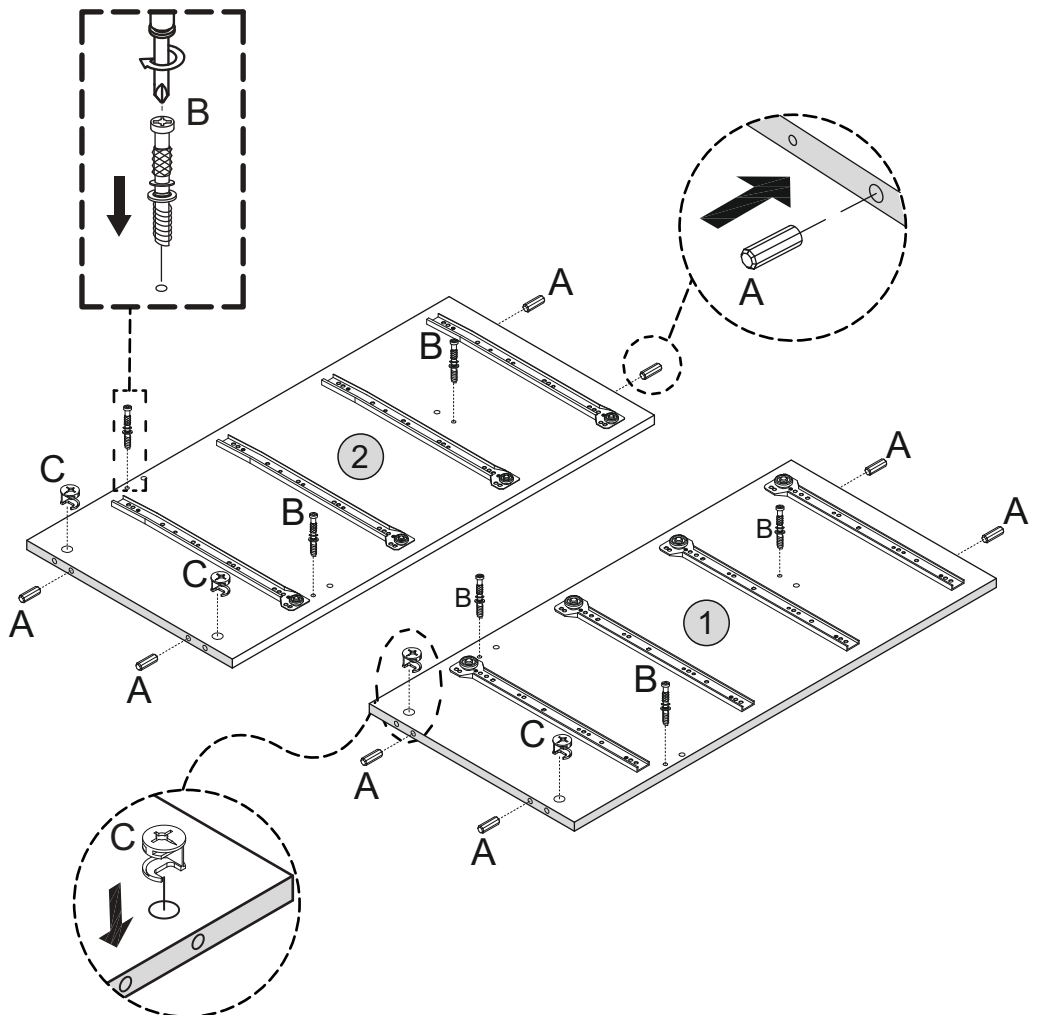
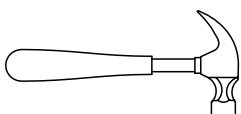
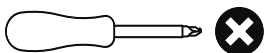



STEP 3

PARTS REQUIRED

8 - CENTRE PANEL x1

HARDWARE REQUIRED

A  02

B  02

C  02

D  3.5x16mm 04

I  01

TOOLS REQUIRED

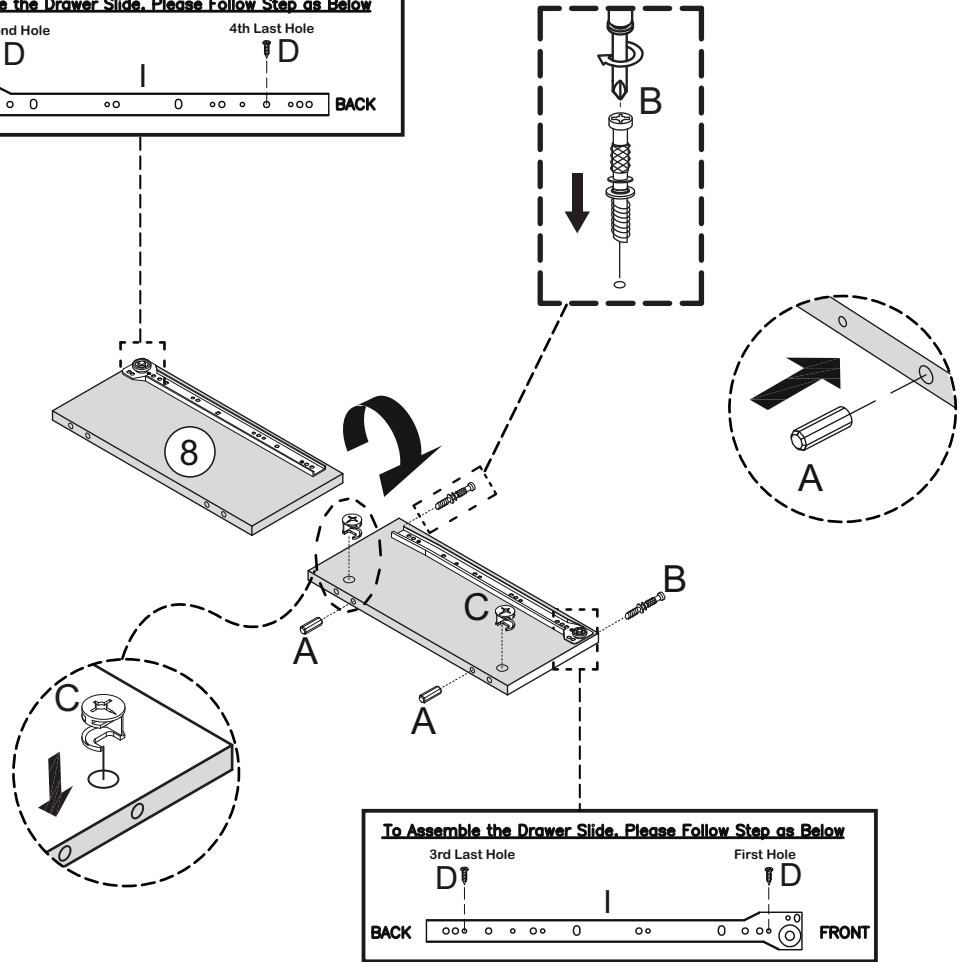
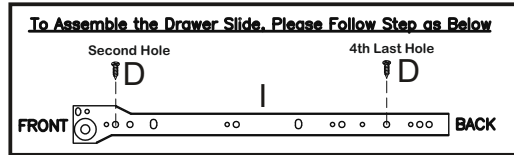
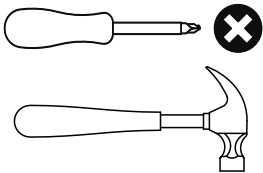

STEP 4

PARTS REQUIRED

9 - CENTRE SUPPORT PANEL x1

15 - SUPPORT PANEL x2

HARDWARE REQUIRED

A  06

C  08

TOOLS REQUIRED

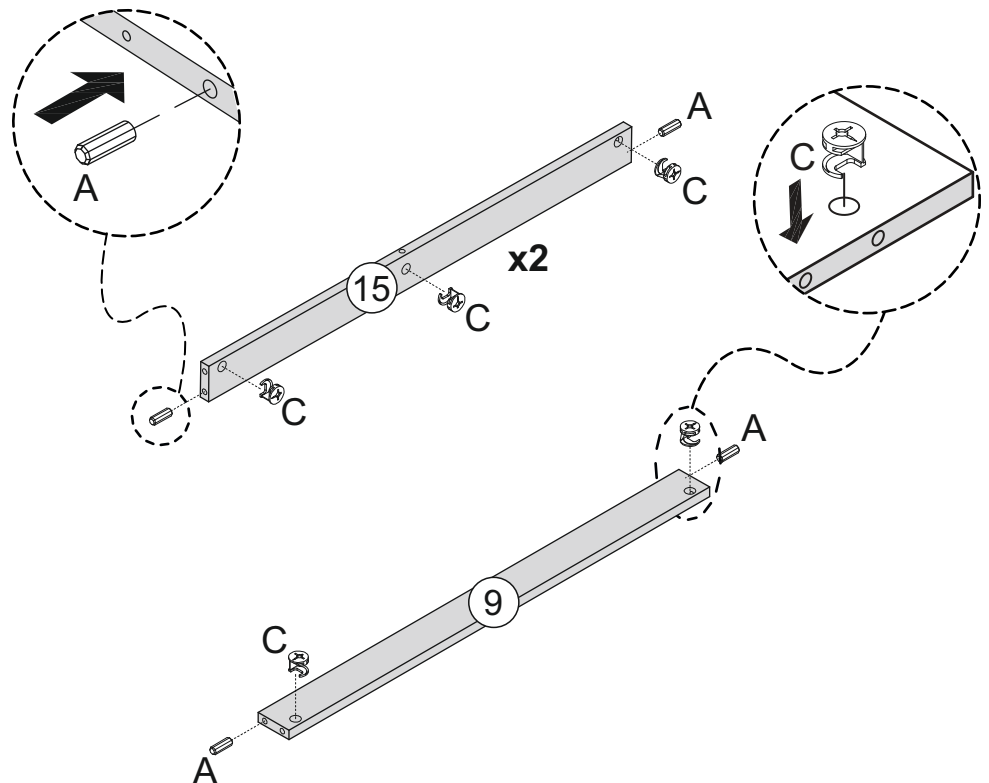
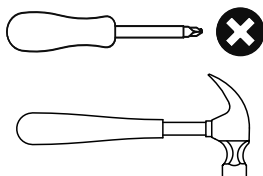

STEP 5

PARTS REQUIRED

4 - TOP PANEL x1

HARDWARE REQUIRED

B  06

TOOLS REQUIRED

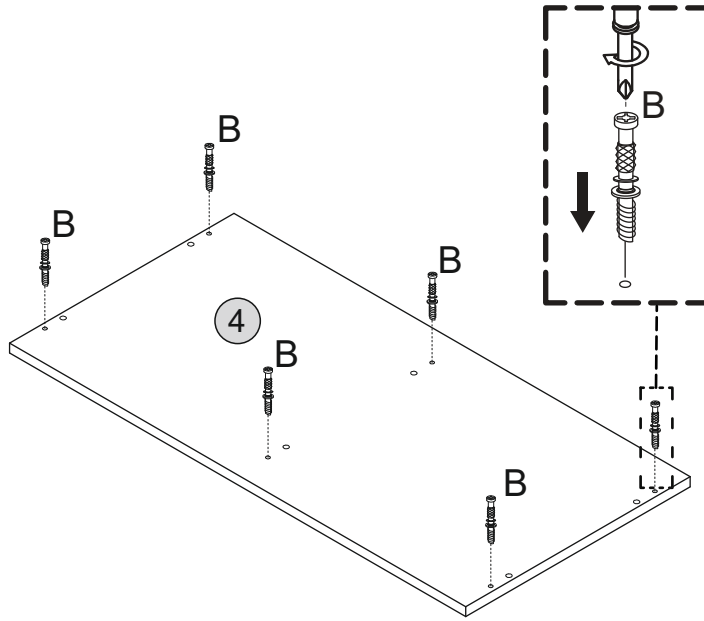

STEP 6

PARTS REQUIRED

8 - CENTRE PANEL x1

15 - SUPPORT PANEL x2

HARDWARE REQUIRED

TOOLS REQUIRED

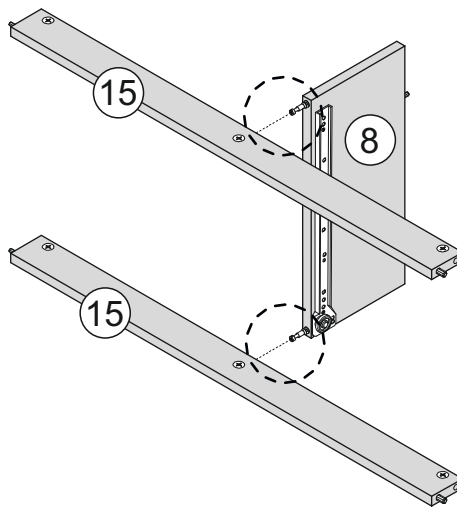
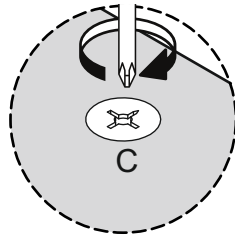
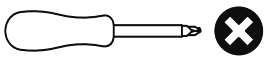

WHEN FITTING CAMS
 ENSURE STARTING POSITION IS CORRECT
 BEFORE YOU INSERT CONNECTING BOLT
 TURN CLOCKWISE UNTIL SECURE

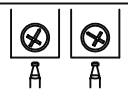
✓   ✗
 ↑ A CORRECT A WRONG A

STEP 7

PARTS REQUIRED

1 - RIGHT SIDE PANEL x1

9 - SUPPORT PANEL x1

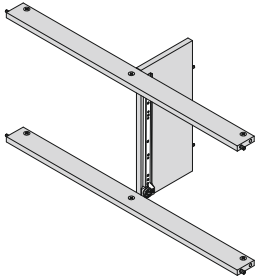

HARDWARE REQUIRED

TOOLS REQUIRED

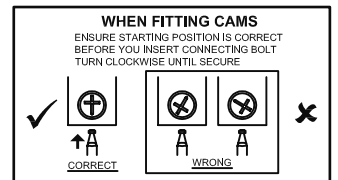
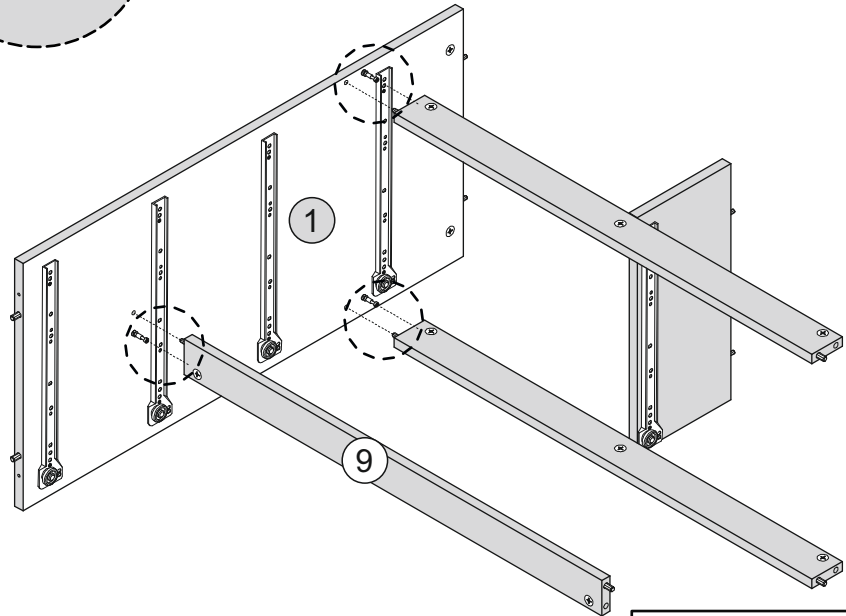
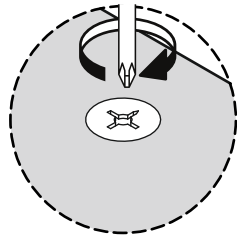
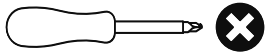

STEP 8

PARTS REQUIRED

2 - LEFT SIDE PANEL x1

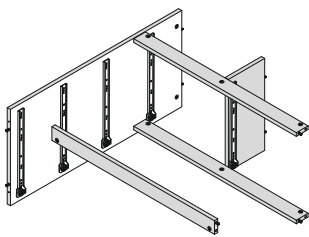

HARDWARE REQUIRED

TOOLS REQUIRED

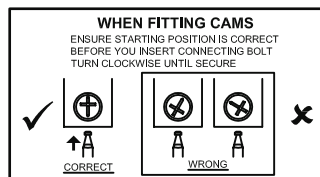
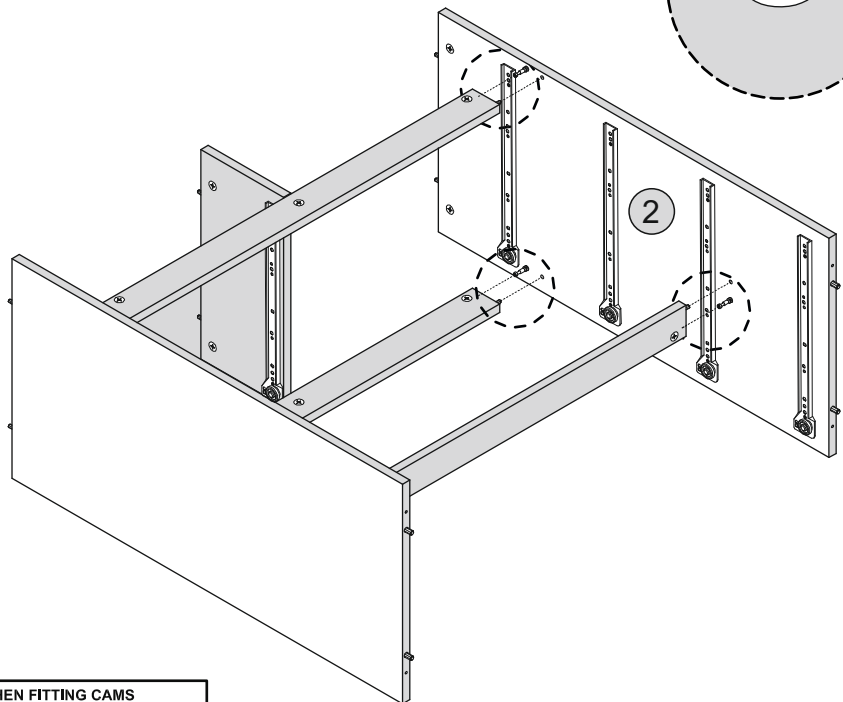
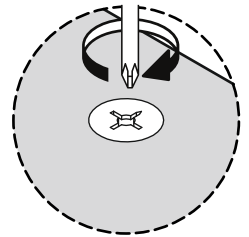
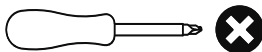

STEP 9

PARTS REQUIRED

4 - TOP PANEL x1

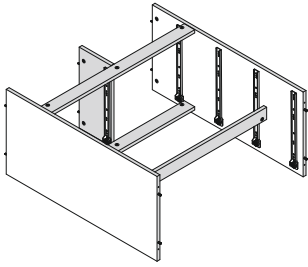

HARDWARE REQUIRED

TOOLS REQUIRED

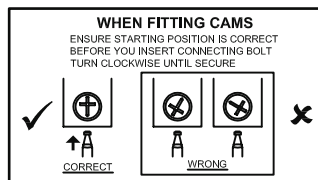
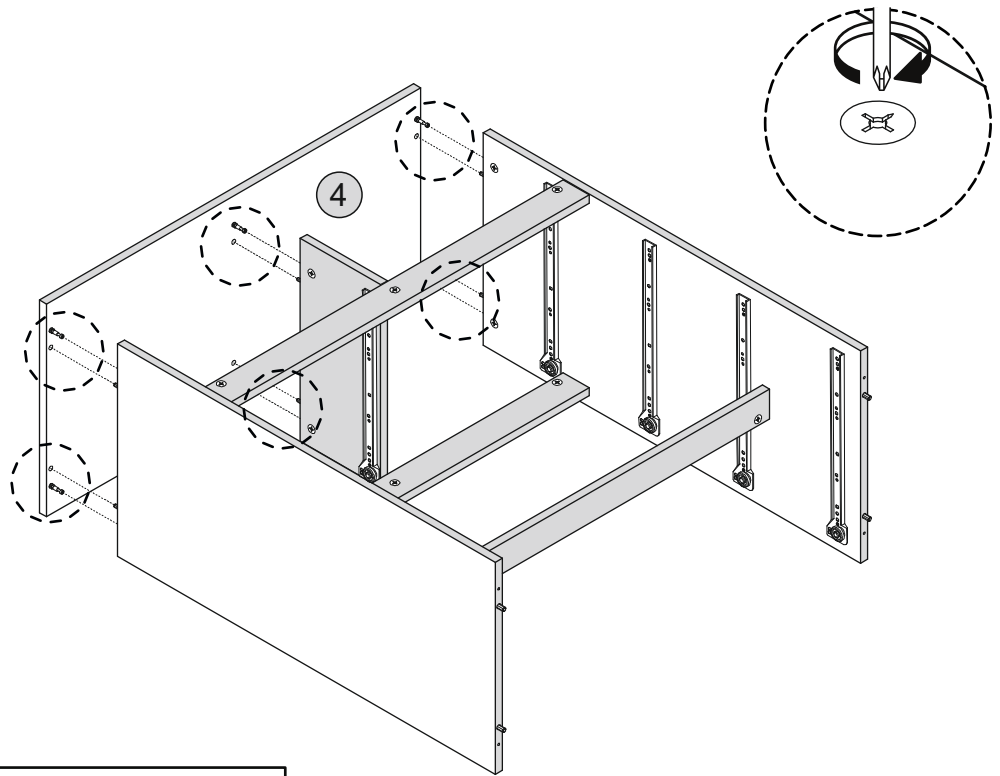
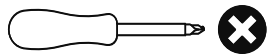

STEP 10

PARTS REQUIRED

5 - BOTTOM PANEL x1

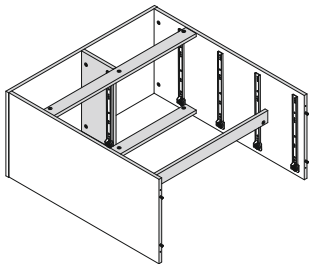

HARDWARE REQUIRED

E 4x45mm 04

TOOLS REQUIRED

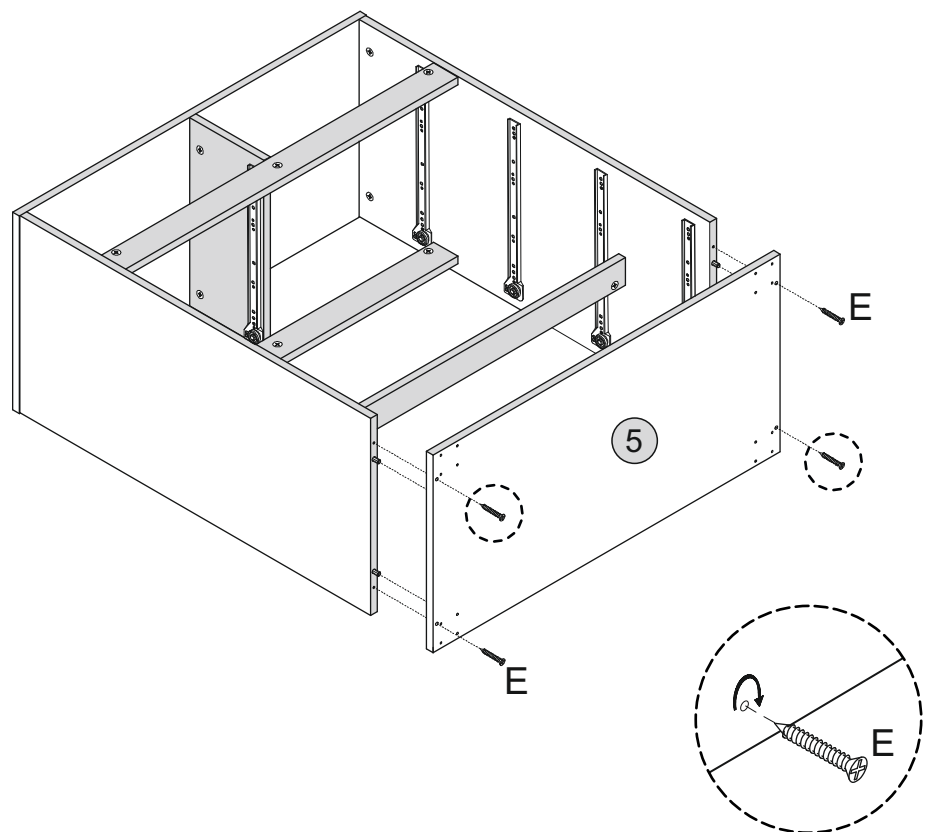
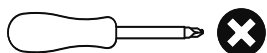

STEP 11

PARTS REQUIRED

18 - BACK PANEL x1

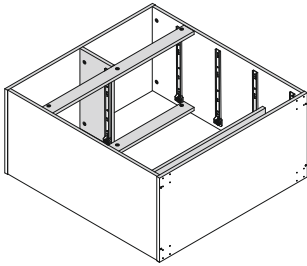

HARDWARE REQUIRED

D  18
3.5x16mm

J  34

L  04

TOOLS REQUIRED

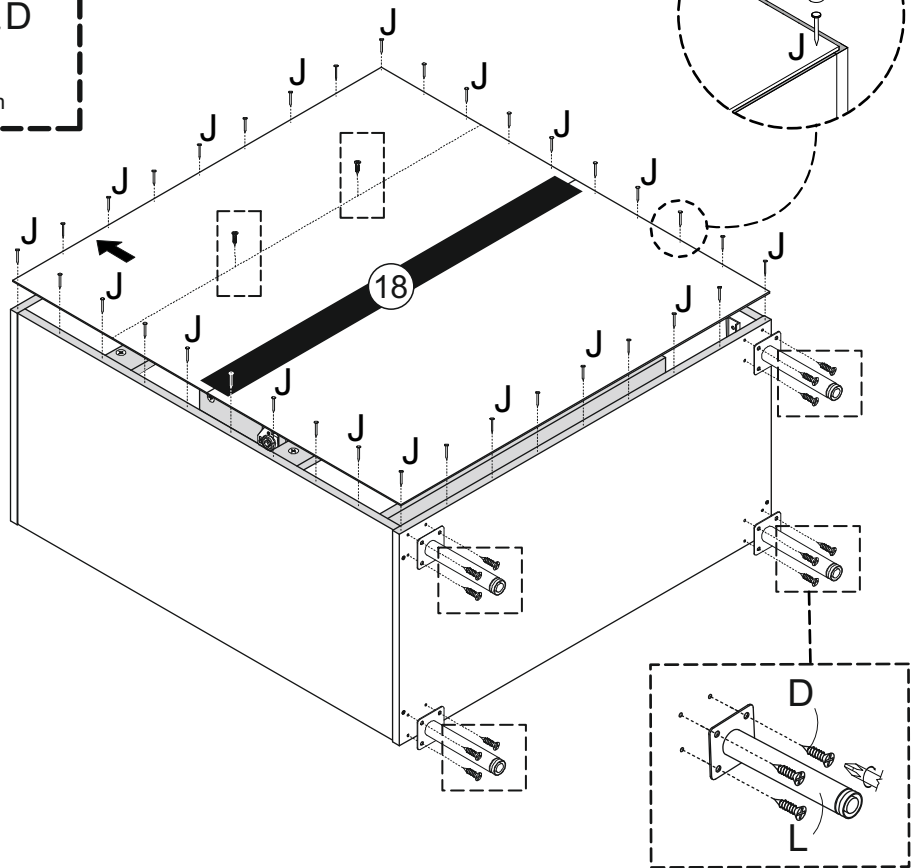
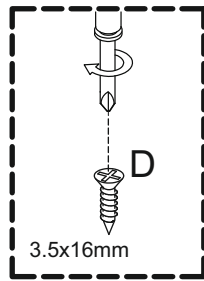
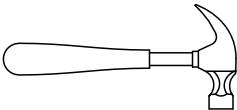
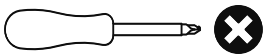

STEP 12

PARTS REQUIRED

6 - RIGHT DRAWER SIDE x5

7 - LEFT DRAWER SIDE x5

HARDWARE REQUIRED

A  20

C  10

TOOLS REQUIRED

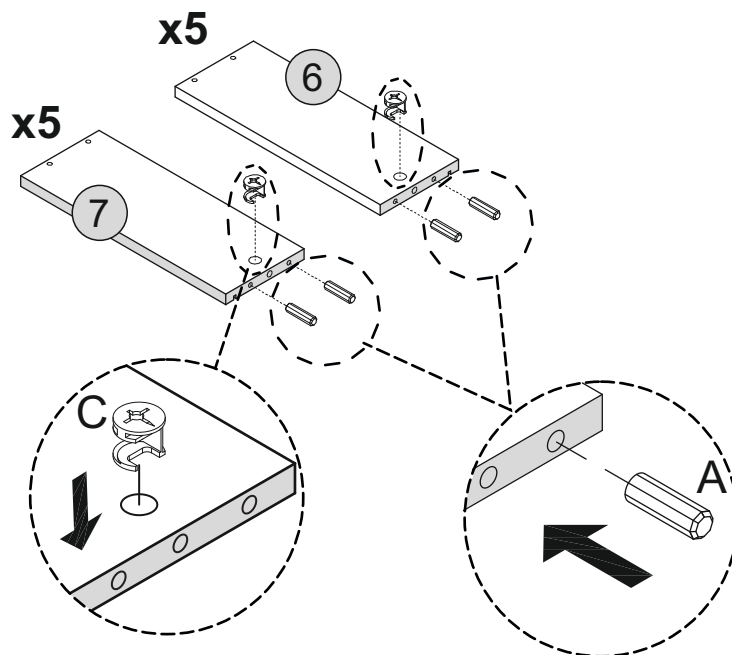
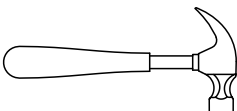

STEP 13

PARTS REQUIRED

3 - LARGE DRAWER FRONT x3

12 - SMALL DRAWER FRONT (R)x1

13 - SMALL DRAWER FRONT (L) x1

14 - DRAWER SUPPORT x3

HARDWARE REQUIRED

B  13

K  03

TOOLS REQUIRED

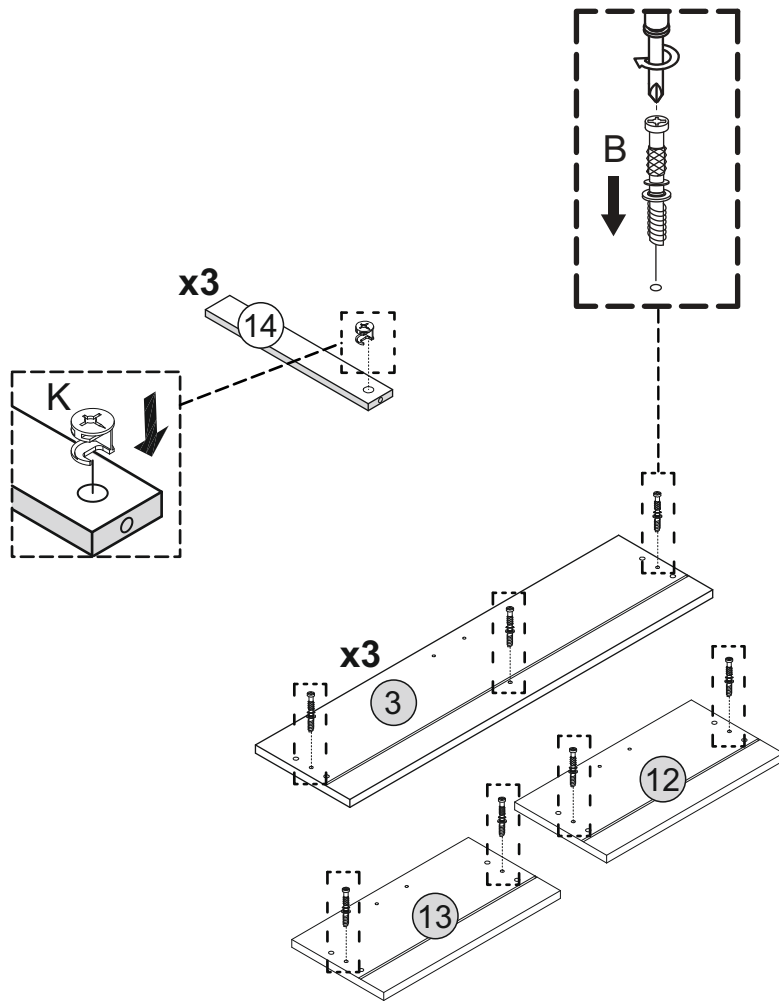
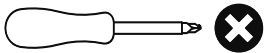

STEP 14

PARTS REQUIRED

6 - RIGHT DRAWER SIDE x3

7 - LEFT DRAWER SIDE x3

10 - LARGE DRAWER BACK x3

14 - DRAWER SUPPORT x3

16 - LARGE DRAWER BASE x3

HARDWARE REQUIRED

F  4x38mm 15

TOOLS REQUIRED

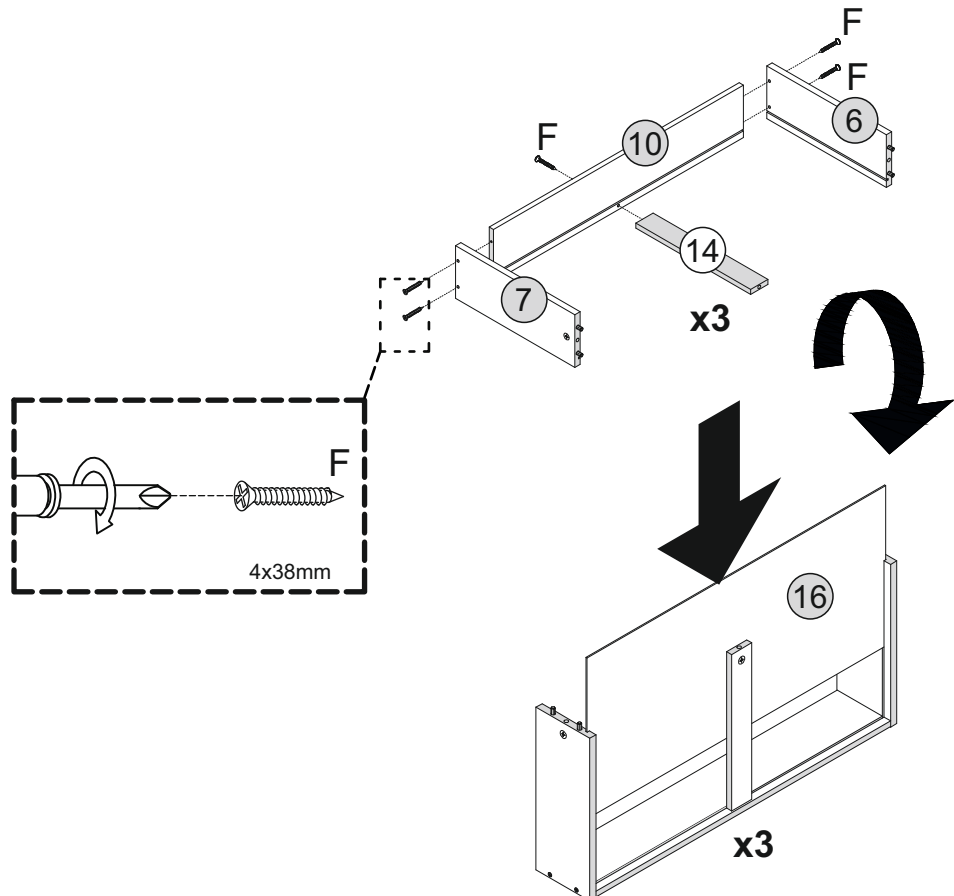
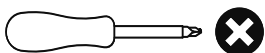

STEP 15

PARTS REQUIRED

- 6 - RIGHT DRAWER SIDE x2
- 7 - LEFT DRAWER SIDE x2
- 11 - SMALL DRAWER BACK x2
- 17 - SMALL DRAWER BASE x2

HARDWARE REQUIRED

- F  08

TOOLS REQUIRED

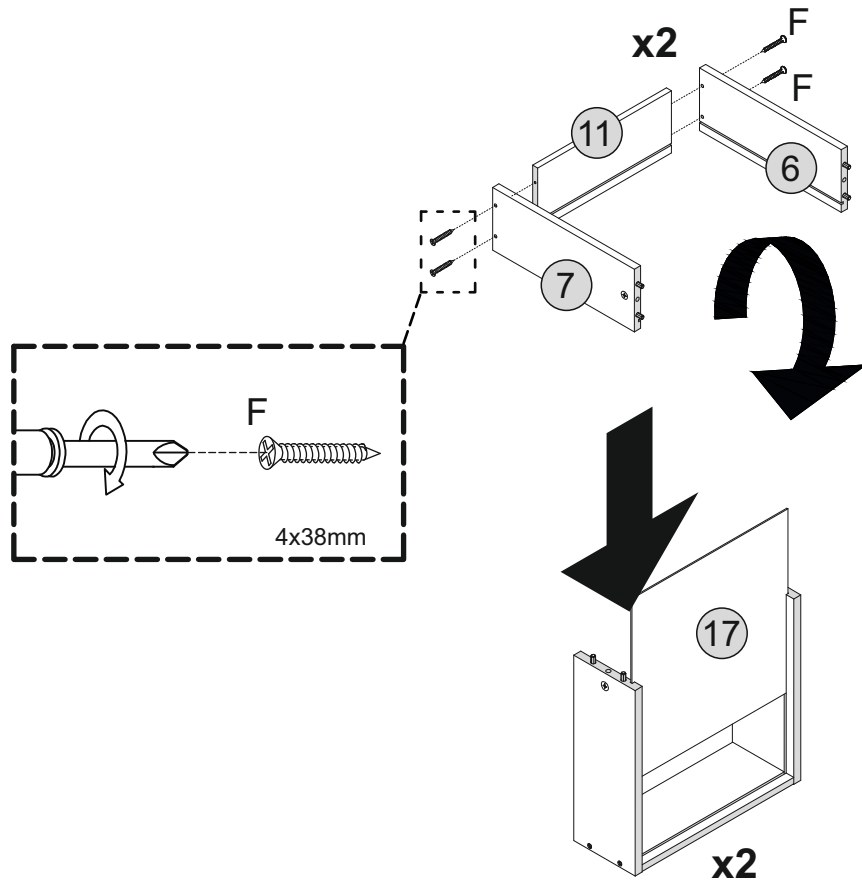
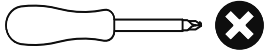

STEP 16

PARTS REQUIRED

- 3 - DRAWER FRONT x1
- 12 - SMALL DRAWER FRONT (R) x1
- 13 - SMALL DRAWER FRONT (L) x1

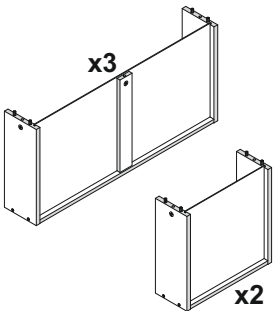

HARDWARE REQUIRED

TOOLS REQUIRED

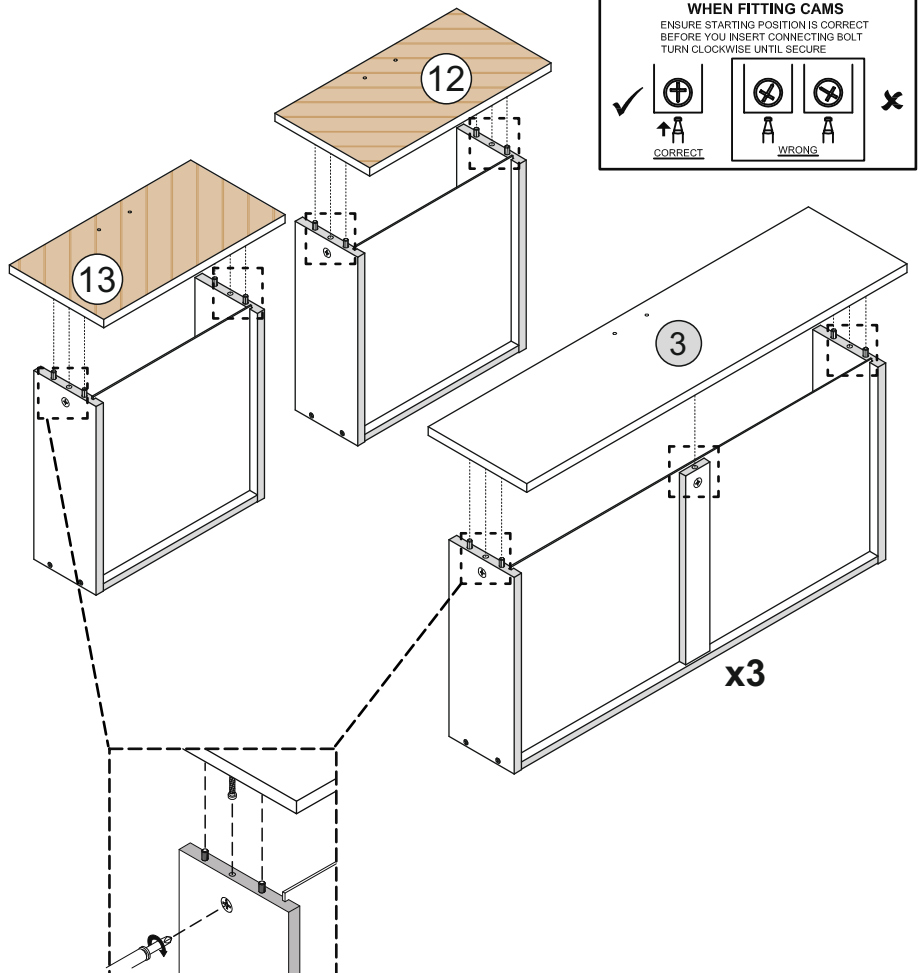
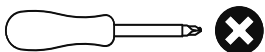

STEP 17

PARTS REQUIRED

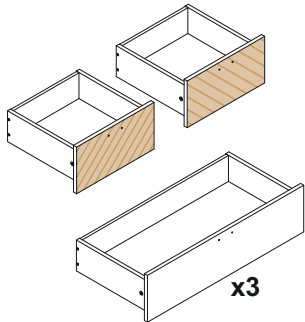

HARDWARE REQUIRED

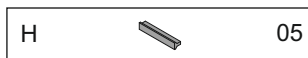

TOOLS REQUIRED

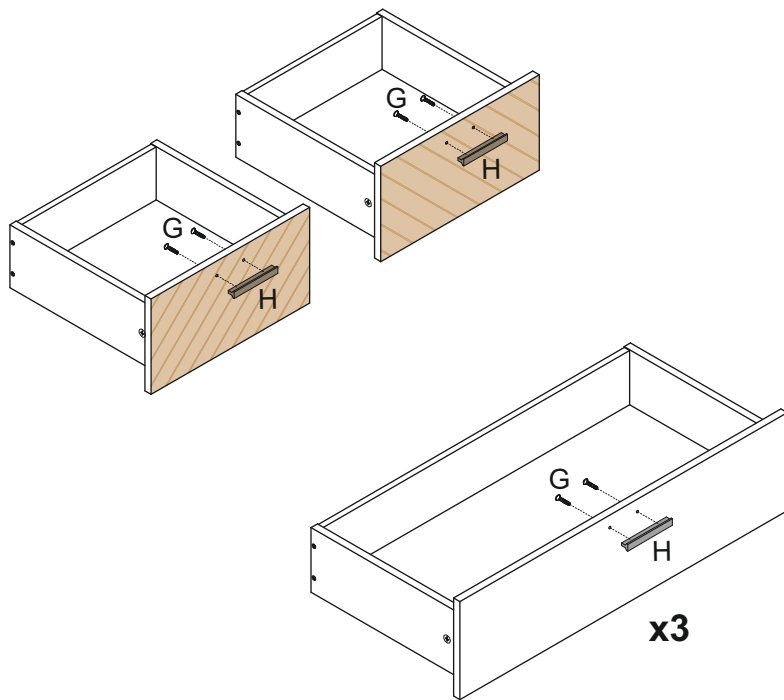
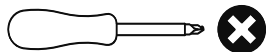

STEP 18

PARTS REQUIRED

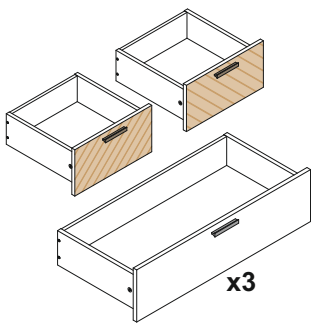

HARDWARE REQUIRED

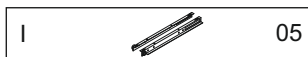
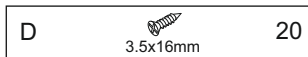

TOOLS REQUIRED

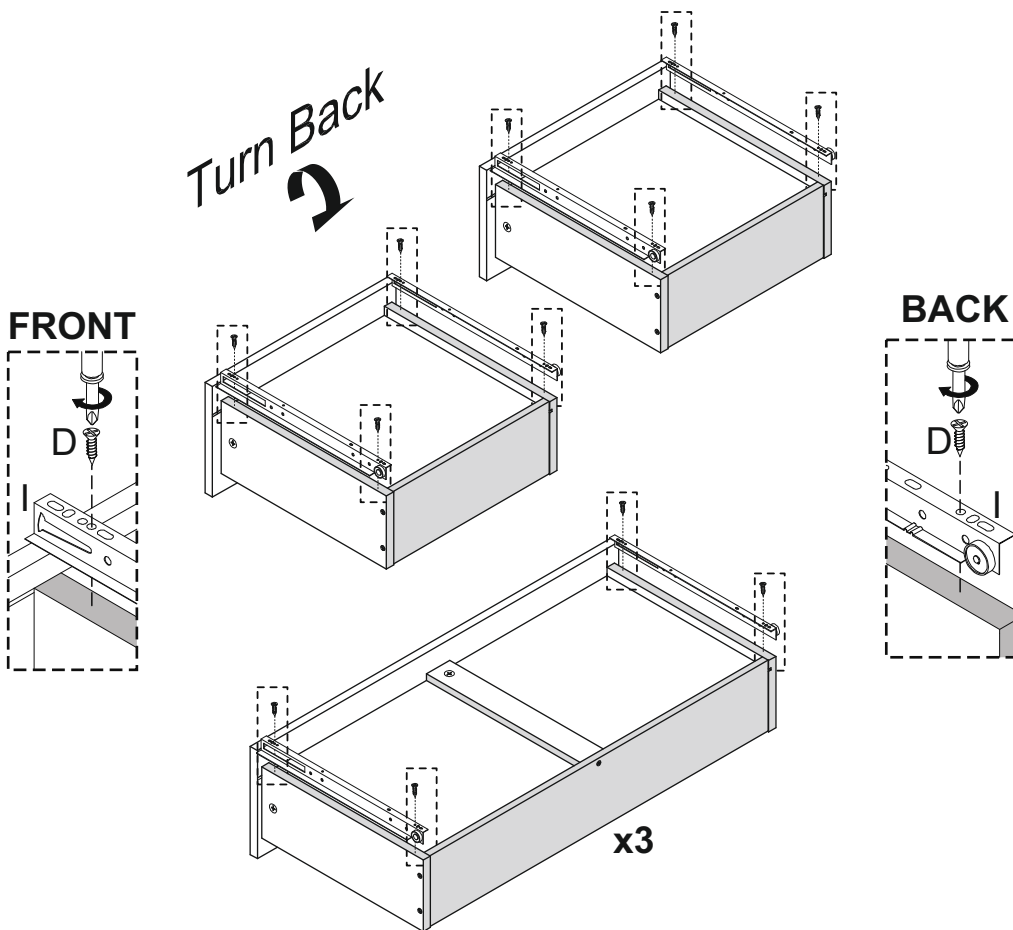
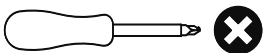

STEP 19

PARTS REQUIRED

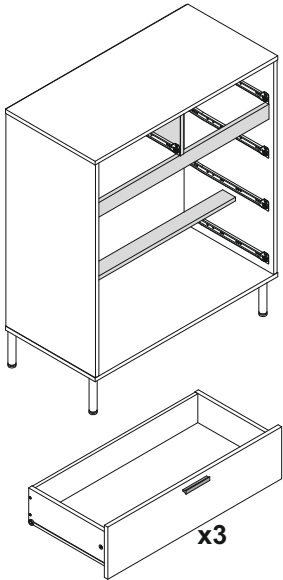

HARDWARE REQUIRED

TOOLS REQUIRED

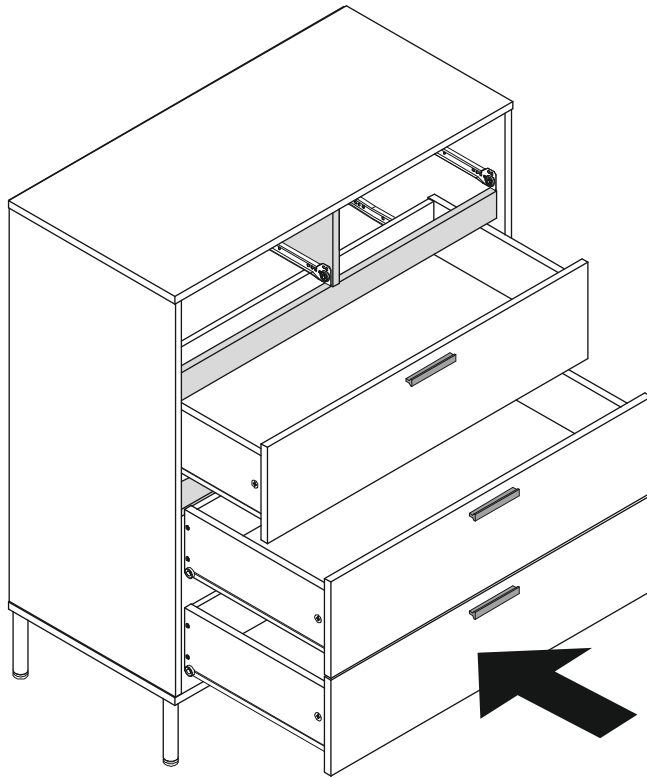

STEP 20

PARTS REQUIRED

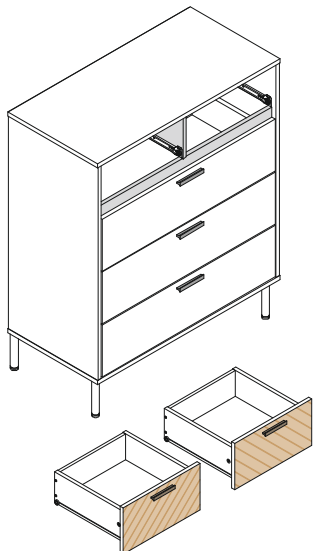

HARDWARE REQUIRED

TOOLS REQUIRED

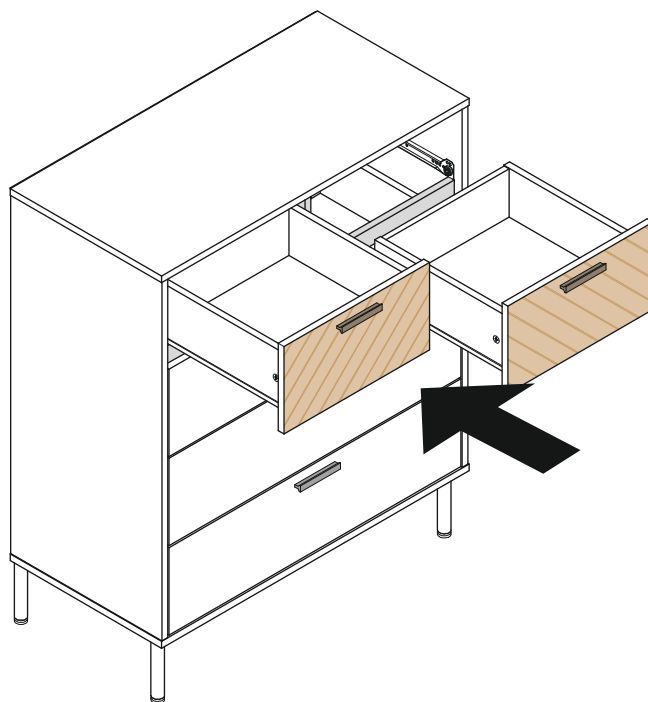

STEP 21

PARTS REQUIRED

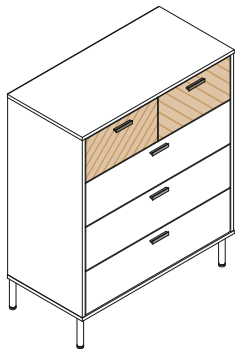

HARDWARE REQUIRED



TOOLS REQUIRED

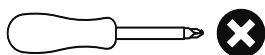

WARNING

Serious or fatal injuries can occur from furniture tipping over. To prevent the furniture from tipping over we recommend that it is permanently fixed to the wall.

Wall fixings are not supplied with this product as different wall materials require different types of fixing devices. Please make sure you use fixings suitable for the walls in your home.

