

# LEON 1 DOOR 2 SHELF CABINET ASSEMBLY INSTRUCTIONS

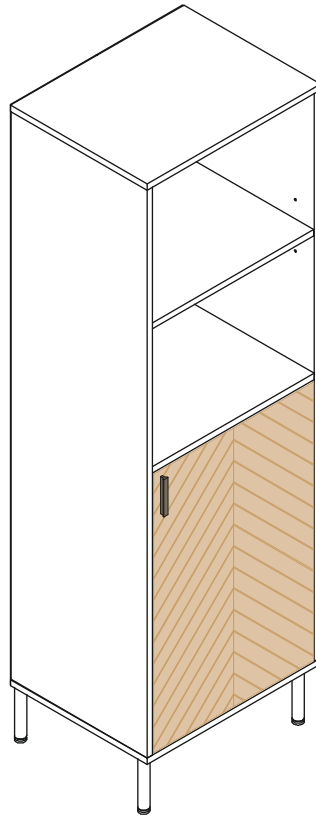

**FOR DOMESTIC USE ONLY  
IMPORTANT**

**PLEASE READ BEFORE YOU CONTINUE FURTHER**

THE PRODUCT YOU HAVE PURCHASED WILL GIVE YOU MANY YEARS OF SERVICE IF YOU FOLLOW THE GUIDELINES FOR ITS SAFE ASSEMBLY AND PERIODIC MAINTENANCE AND CLEANING.

ASSEMBLE ON A SOFT CLEAN SURFACE.

DO NOT USE ANY TOOLS OTHER THAN THOSE SHOWN.

ANY SPANNERS OR ALLEN KEYS REQUIRED ARE INCLUDED WITH THE FITTING KIT.

DO NOT FOR ANY REASON USE A POWER TOOL TO ASSEMBLE THIS PRODUCT. ITS USE WILL INVALIDATE ANY CLAIM YOU MAY HAVE AND COULD MAKE THIS PRODUCT UNSAFE.

DEPENDING ON THE AMOUNT OF USE THIS PRODUCT RECEIVES, IT MAY BE NECESSARY TO TIGHTEN UP THE FIXINGS FROM TIME TO TIME. THIS IS COMPLETELY NORMAL FOR ANY FLAT PACK FURNITURE. DO NOT OVERTIGHTEN FIXINGS.

FOR CLEANING, YOU MAY USE A DAMP CLOTH (NOT WET). DO NOT USE POLISH, DETERGENT OR CHEMICAL CLEANERS.



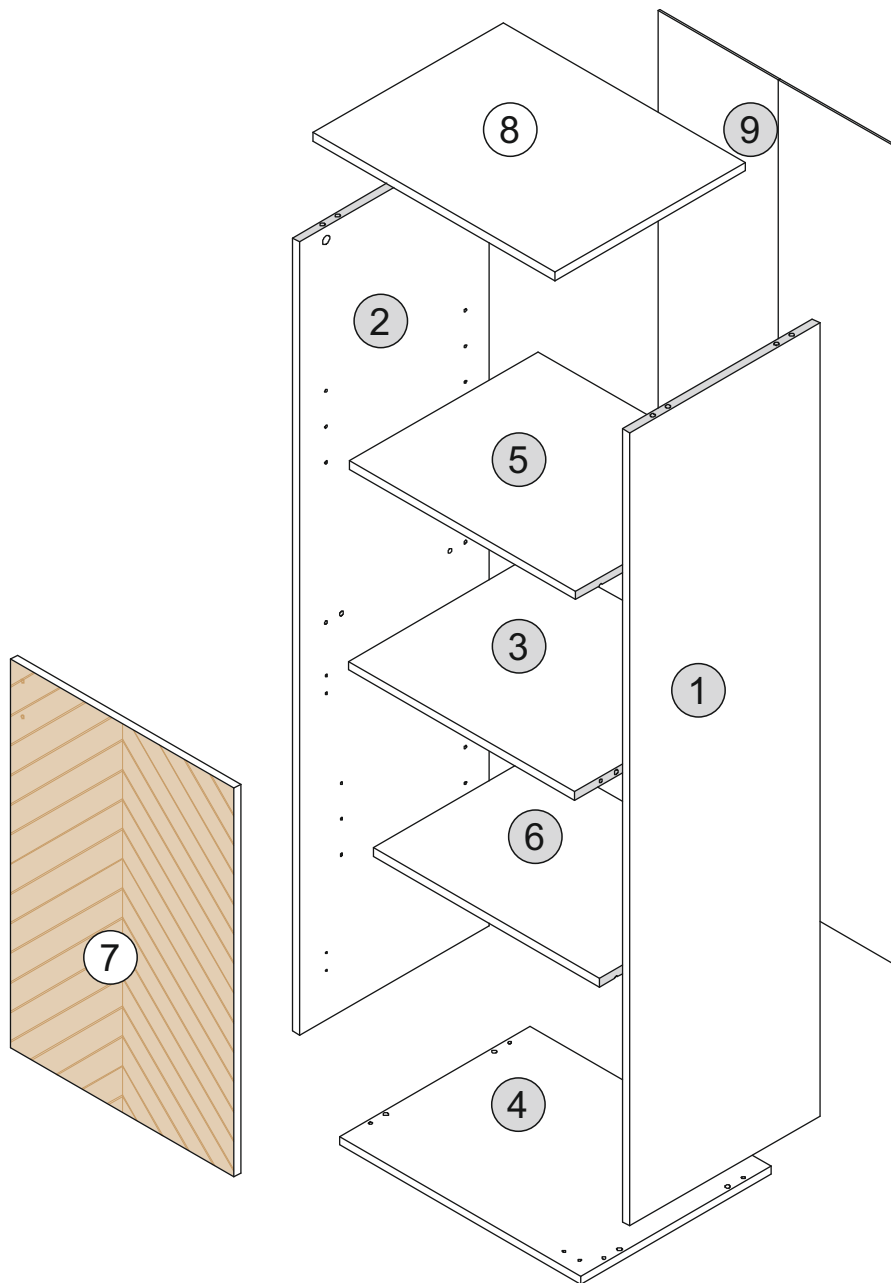











THIS SURFACE OF THIS ITEM IS NOT HEAT RESISTANT. ALWAYS USE A PLACE MAT UNDER HOT OR COLD ITEMS TO PREVENT MARKING.



## PART LIST

Part Number	Part Code	Part Description	Quantity	Carton
1	S300-320-036-ZF1-01	Right Side Panel	1	1/1
2	S300-320-036-ZF1-01	Left Side Panel	1	1/1
3	S300-320-036-ZF1-01	Shelf Panel	1	1/1
4	S300-320-036-ZF1-01	Bottom Panel	1	1/1
5	S300-320-036-ZF1-01	Large Shelf Panel	1	1/1
6	S300-320-036-ZF1-01	Small Shelf Panel	1	1/1
7	S300-320-036-ZF1-01	Door	1	1/1
8	S300-320-036-ZF1-01	Top Panel	1	1/1
9	S300-320-036-ZF1-01	Back Panel	1	1/1

# HARDWARE LIST

No	Part Name		Qty	Carton
A	M8x30mm Wooden Dowel		x12	1
B	Minifix Cam Bolt (8032t)		x8	1
C	Minifix Cam Nut (1512)		x8	1
D	M3.5x16mm Screw		x24	1
E	M4x45mm Screw		x4	1
F	Iron Leg (150mm) - Black		x4	1
G	20mm Handle Screw		x2	1
H	Handle (64mm)		x1	1
I	End Hinges (M11)		x2	1
J	Nail		x42	1
K	Screw Cover (Sticker 22mm)		x8	1
L	Shelf Support		x8	1
M	Door Stopper - Black		x1	1
N	Wall Fixing (4x20mm=1pc)		x1	1

## TIPS FOR FITTINGS CAM-LOCKS

WHEN FITTING CAM NUT. ENSURE STARTING POSITION IS CORRECT BEFORE YOU INSERT CONNECTING CAM BOLT TURN CLOCKWISE UNTIL SECURE



↑

**CORRECT**



↓

**WRONG**

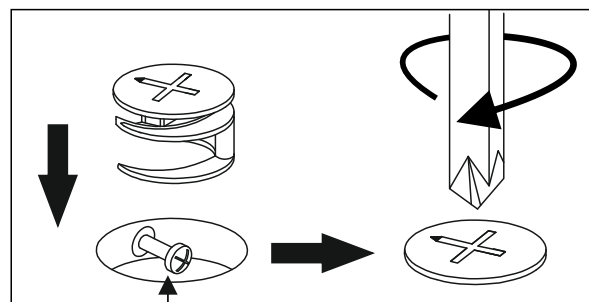

**Cam bolt head needs to be in centre**

### CAMBOLT

**Tighten until shoulder in flush with panel. Do not overtighten or undertighten (see example below)**

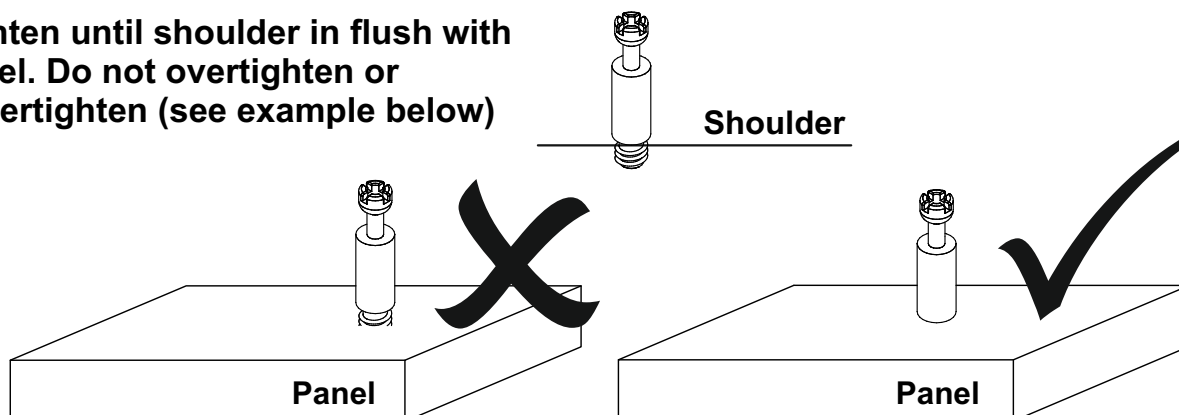

# STEP 1

## PARTS REQUIRED

1 - RIGHT SIDE PANEL x1

2 - LEFT SIDE PANEL x1

## HARDWARE REQUIRED

A  08

B  04

C  04

L  08

## TOOLS REQUIRED

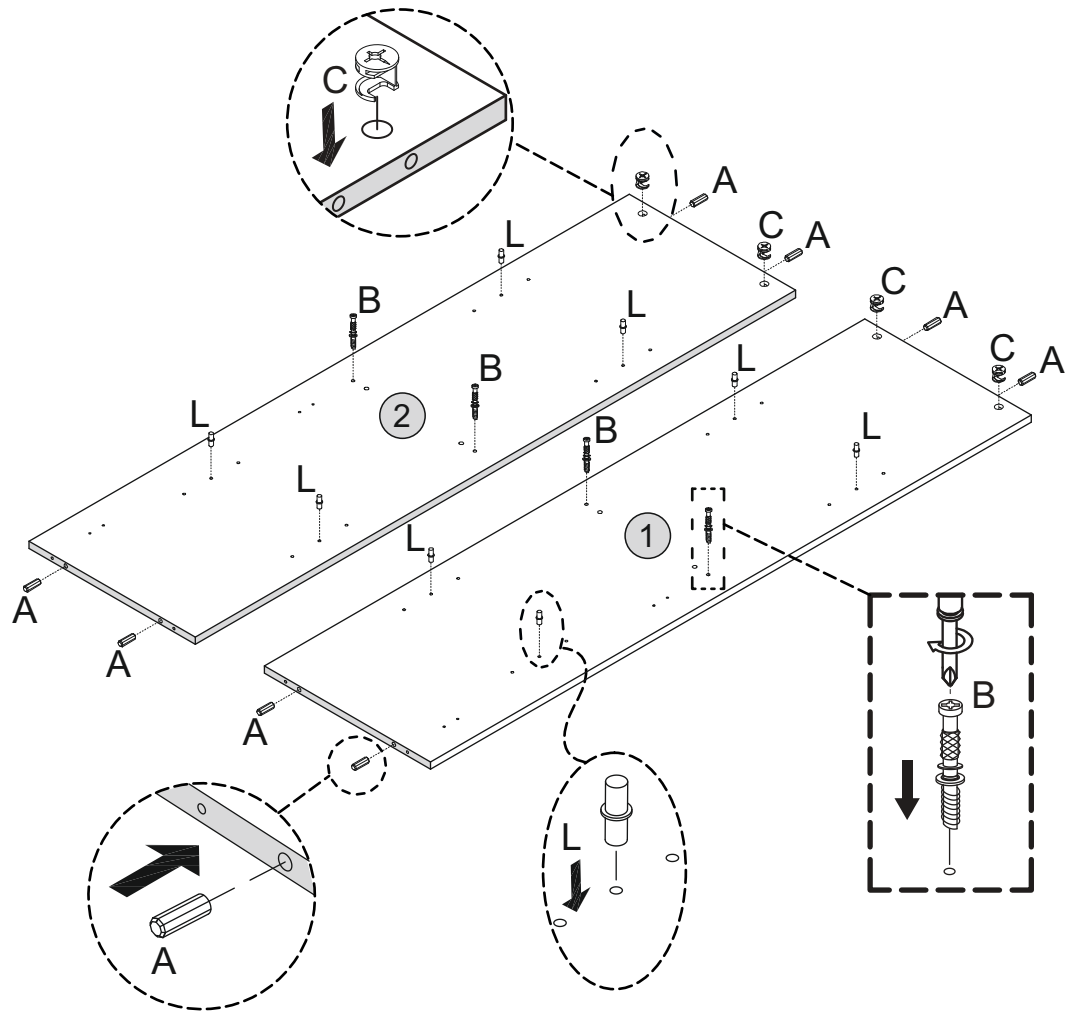
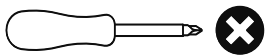
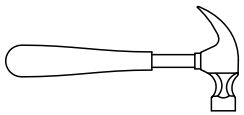

# STEP 2

## PARTS REQUIRED

3 - CENTRE SHELF PANEL x1

8 - TOP PANEL x1

## HARDWARE REQUIRED

A  04

B  04

C  04

M  01

## TOOLS REQUIRED

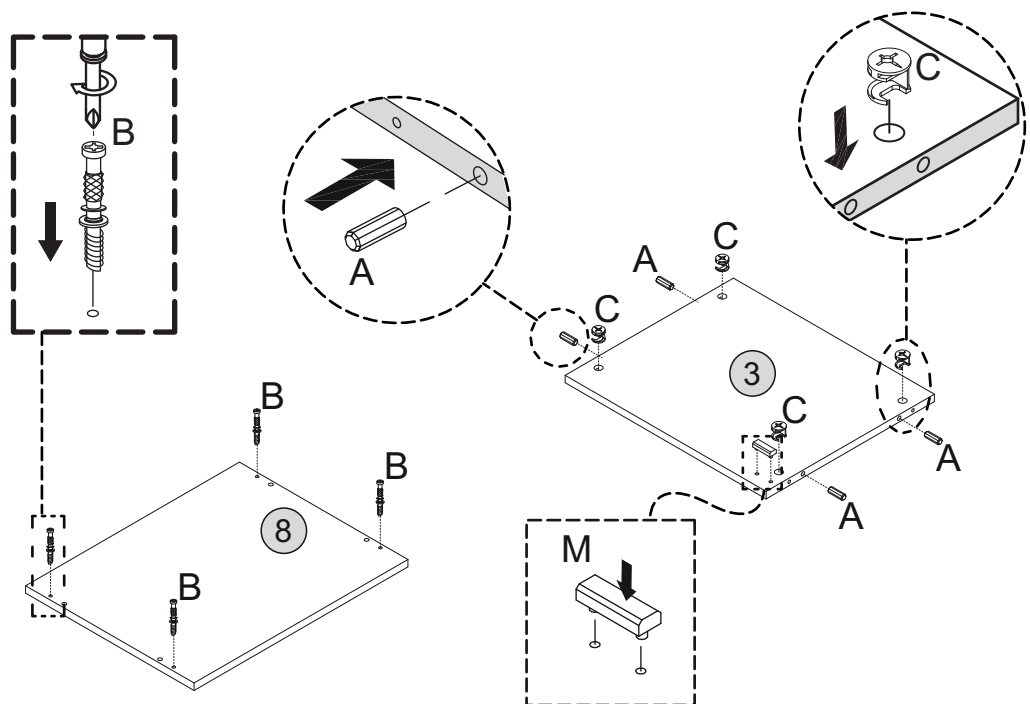
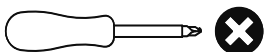
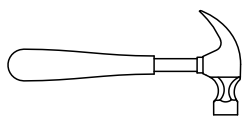

# STEP 3

## PARTS REQUIRED

7 - DOOR x1

## HARDWARE REQUIRED

D  04  
3.5x16mm

I  02

## TOOLS REQUIRED

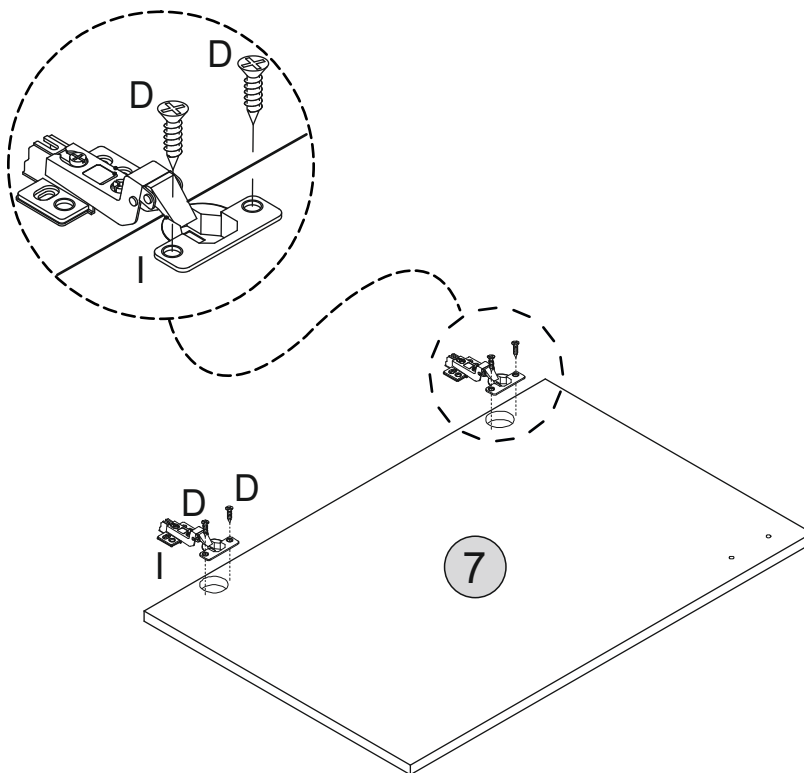
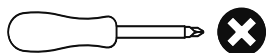

# STEP 4

## PARTS REQUIRED

2 - LEFT SIDE PANEL x1

3 - CENTRE SHELF PANEL x1



## HARDWARE REQUIRED

K  02

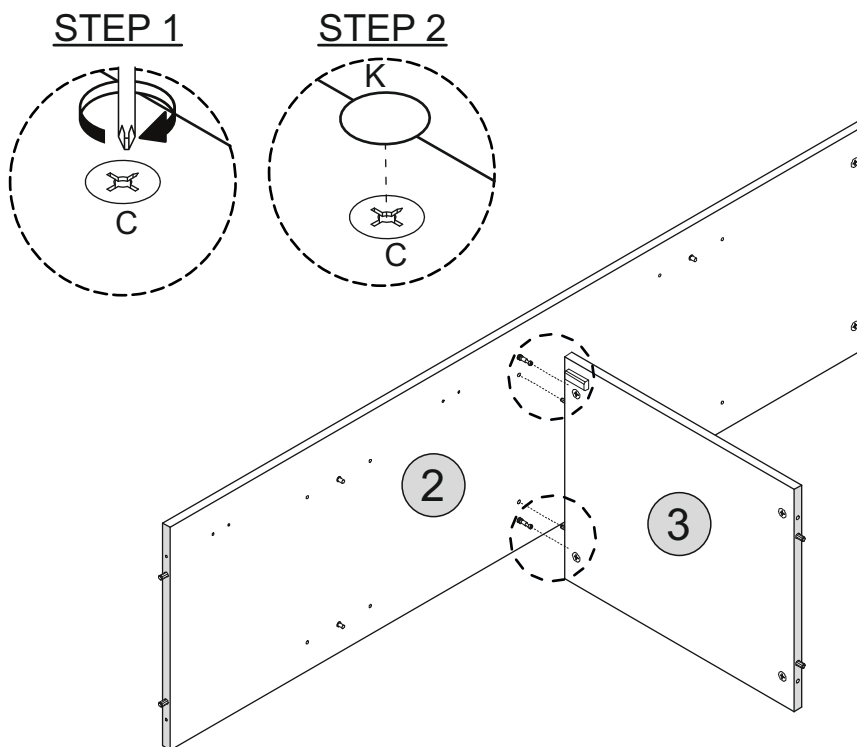
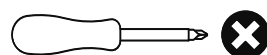
## TOOLS REQUIRED



**WHEN FITTING CAMS**  
ENSURE STARTING POSITION IS CORRECT  
BEFORE YOU INSERT CONNECTING BOLT  
TURN CLOCKWISE UNTIL SECURE

✓				✗
	↑ CORRECT	↑ WRONG	↑ WRONG	

# STEP 5

## PARTS REQUIRED

1 - RIGHT SIDE PANEL x1

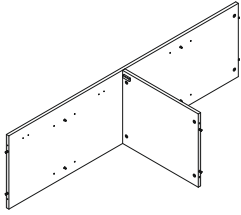

## HARDWARE REQUIRED

K  02

## TOOLS REQUIRED

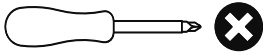

### STEP 1

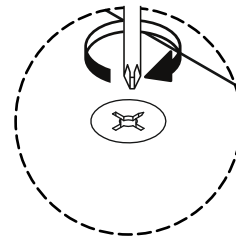

### STEP 2

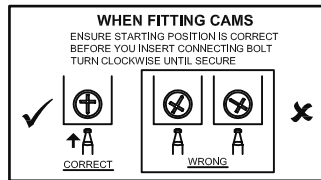
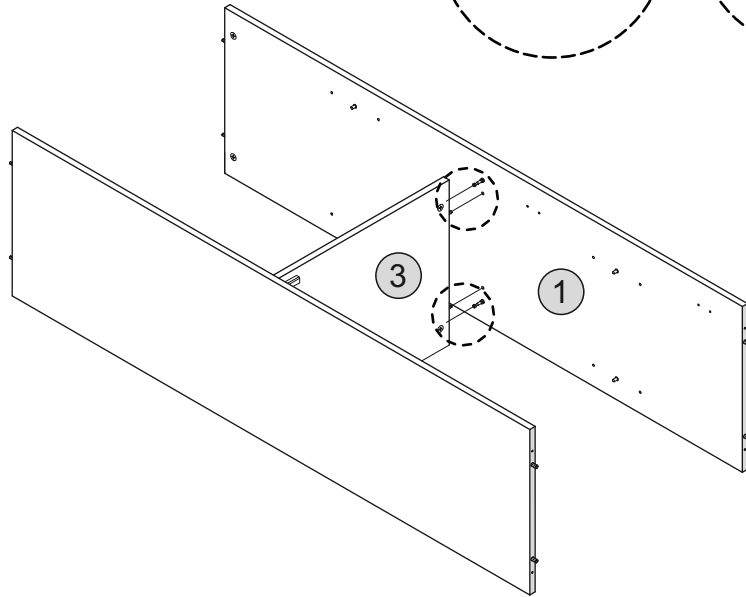
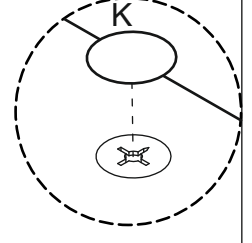

# STEP 6

## PARTS REQUIRED

8 - TOP PANEL x1

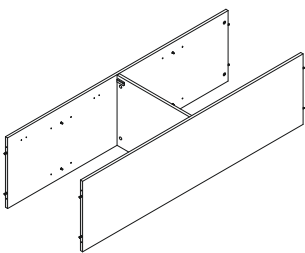

## HARDWARE REQUIRED

K  04

## TOOLS REQUIRED

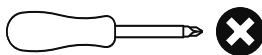

### STEP 1

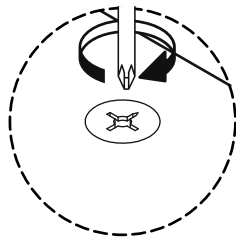

### STEP 2

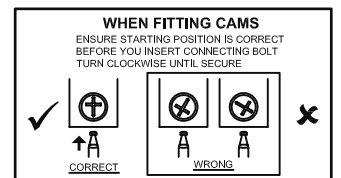
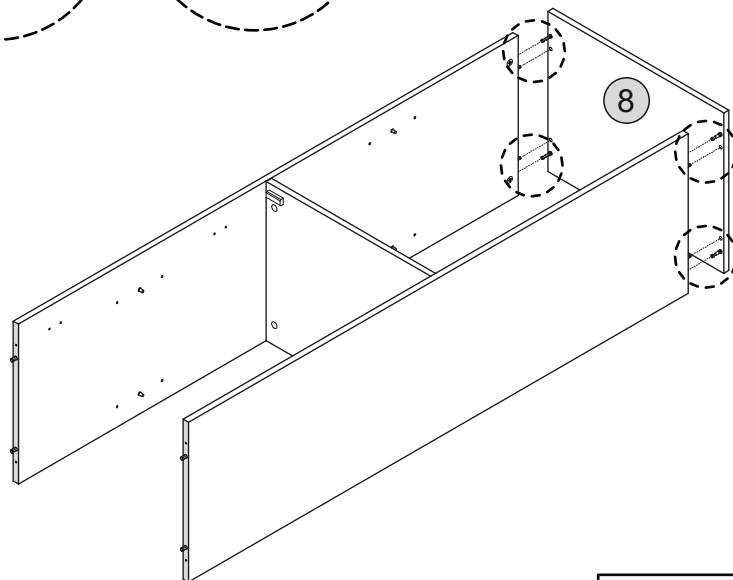
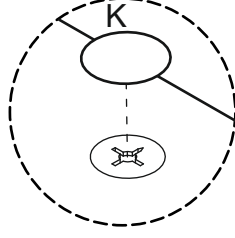

# STEP 7

## PARTS REQUIRED

4 - BOTTOM PANEL x1

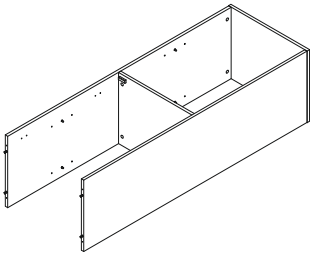

## HARDWARE REQUIRED

E  04  
4x45mm

## TOOLS REQUIRED

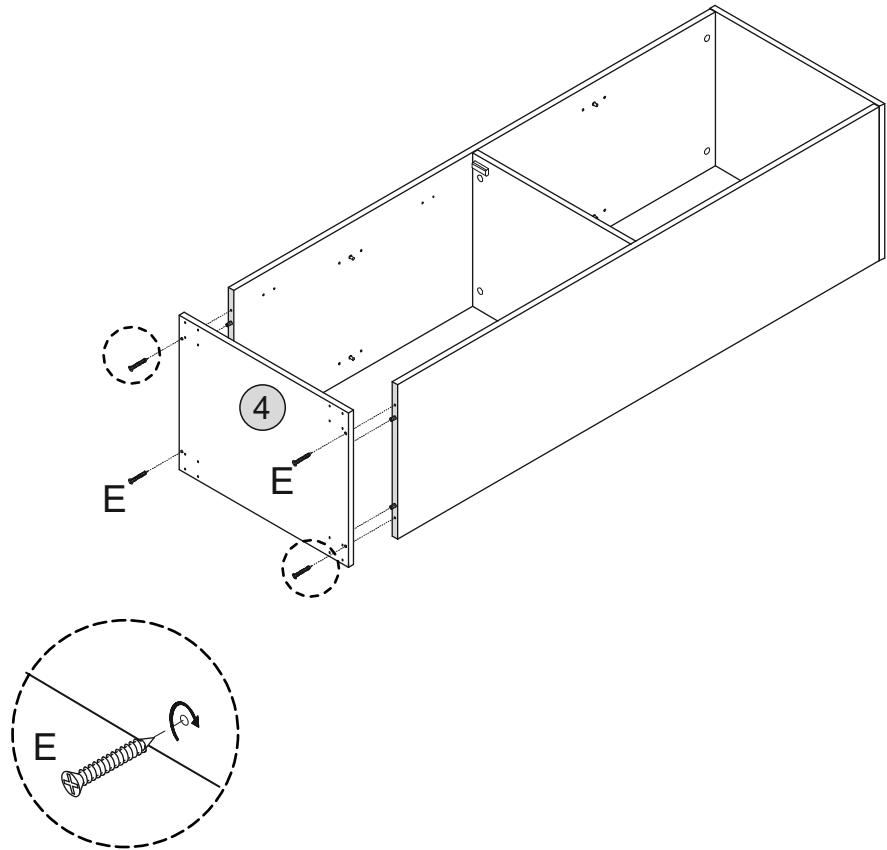
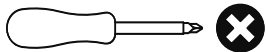

# STEP 8

## PARTS REQUIRED

9 - BACK PANEL x1

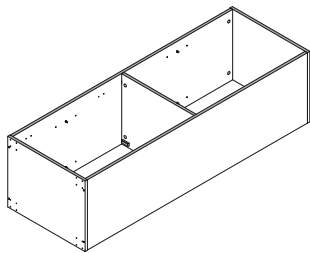

## HARDWARE REQUIRED

D  16  
3.5x16mm

F  04

J  42

## TOOLS REQUIRED

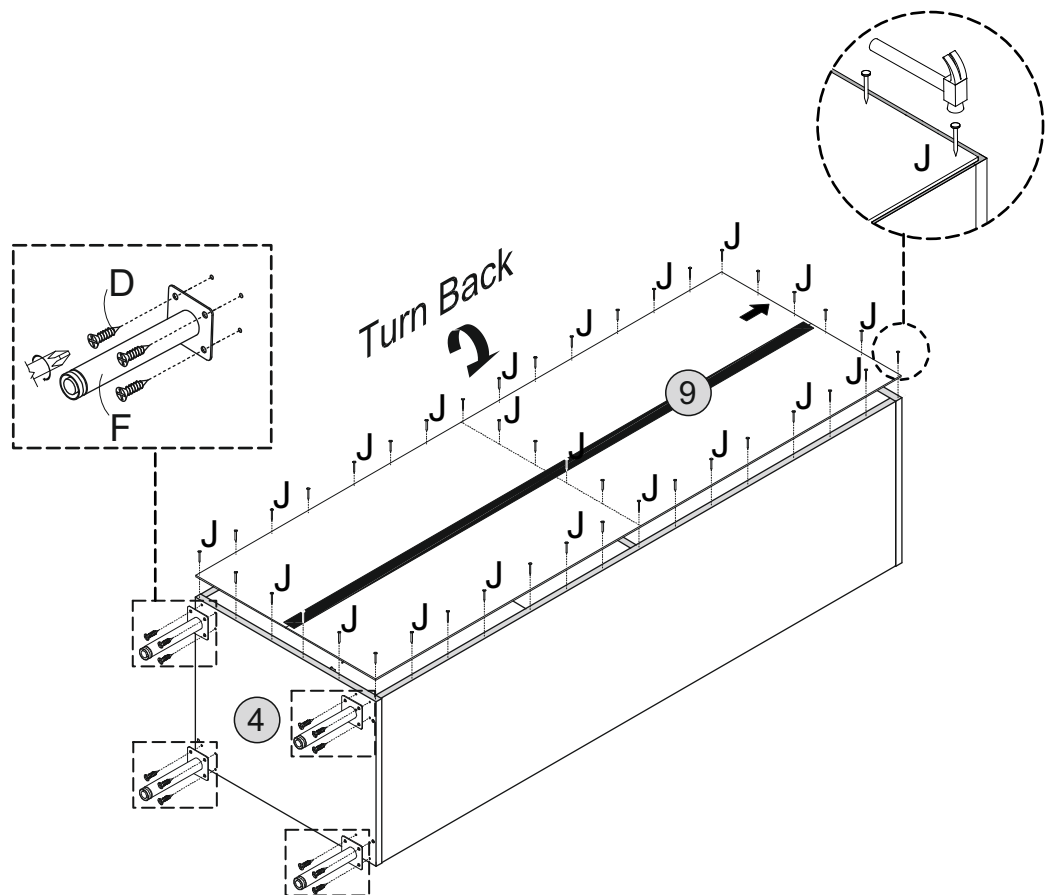
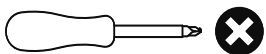

# STEP 9

## PARTS REQUIRED

5 - LARGE SHELF PANEL x1

6 - SMALL SHELF PANEL x1

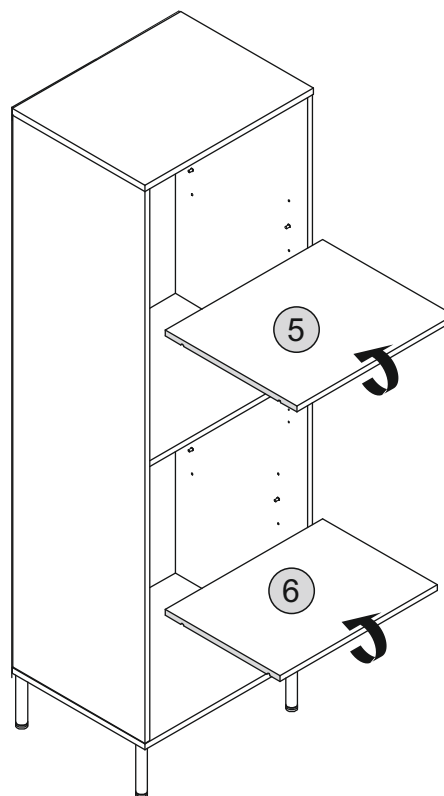
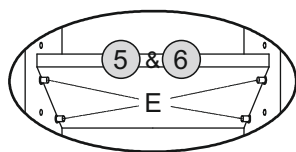
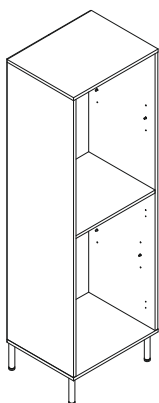

## HARDWARE REQUIRED

## TOOLS REQUIRED

# STEP 10

## PARTS REQUIRED

7 - DOOR x1

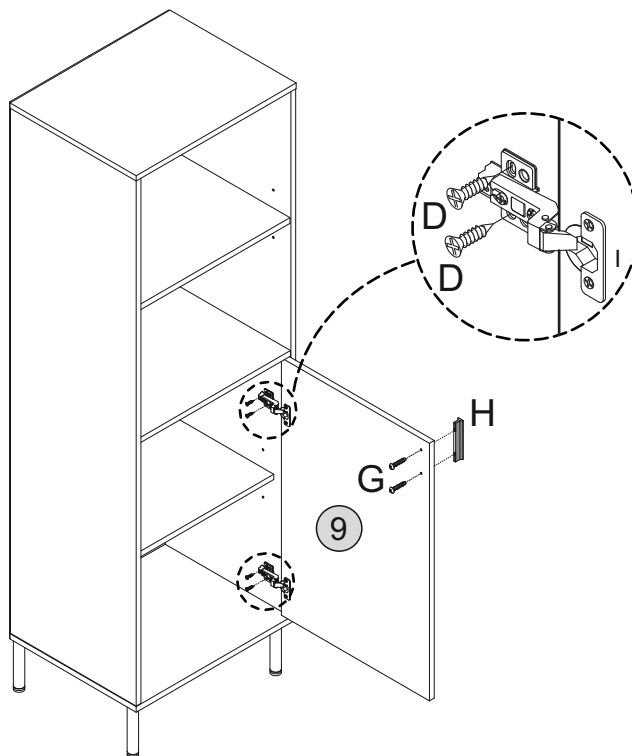
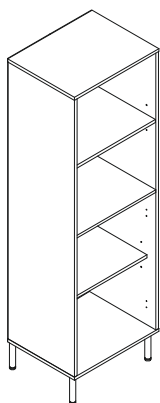

## HARDWARE REQUIRED

D  04  
3.5x16mm

G  02

H  01

## TOOLS REQUIRED

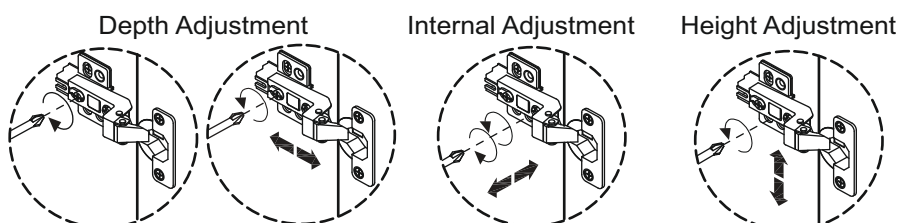
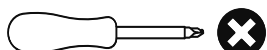



# STEP 11

## PARTS REQUIRED

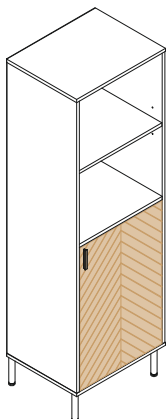

## HARDWARE REQUIRED



## TOOLS REQUIRED

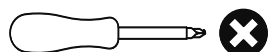

## WARNING

**Serious or fatal injuries can occur from furniture tipping over. To prevent the furniture from tipping over we recommend that it is permanently fixed to the wall.**

Wall fixings are not supplied with this product as different wall materials require different types of fixing devices. Please make sure you use fixings suitable for the walls in your home.

