

NEVADA DRESSING TABLE SET ASSEMBLY INSTRUCTIONS

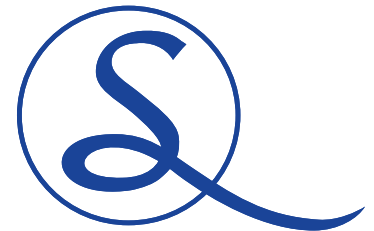
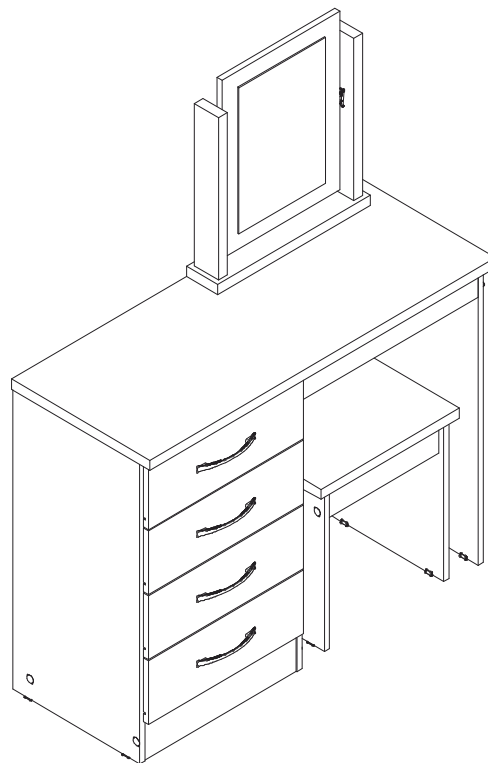

IMPORTANT FOR DOMESTIC USE ONLY

PLEASE READ BEFORE YOU CONTINUE FURTHER

CARE AND MAINTENANCE

After unpacking this product please keep the original packaging in case it needs to be returned for any reason.

- Please ensure all fittings and parts are present before commencing with assembly.
- Never drag or push products as this could cause damage to the joints making it inferior.
- We strongly recommend that you keep children away from your work area.
- We recommend that you lay a blanket or sheet on the floor to avoid damage to both your floor and the product.
- Assemble this product as close to its final position as possible.
- Do not place this product next to a radiator or in direct sunlight.
- Do not drag or push items across your high gloss furniture as this may cause the surface to scratch
- Wood is a natural product and may expand if subjected to damp and may shrink or crack if subjected to heat. Therefore it is recommended that room temperature is maintained, with no sudden temperature fluctuations.
- Make sure any spillage is wiped off immediately.
- Do not place hot or chilled items directly on to the surface, use a place mat or marking will occur.
- For general cleaning use a soft cotton or micro fibre cloth, and do not use detergents of any kind.
- From time to time it may be necessary to tighten fittings, regular inspections should be carried out.
- Do not place on a wet or damp floor as staining may occur to your floor.

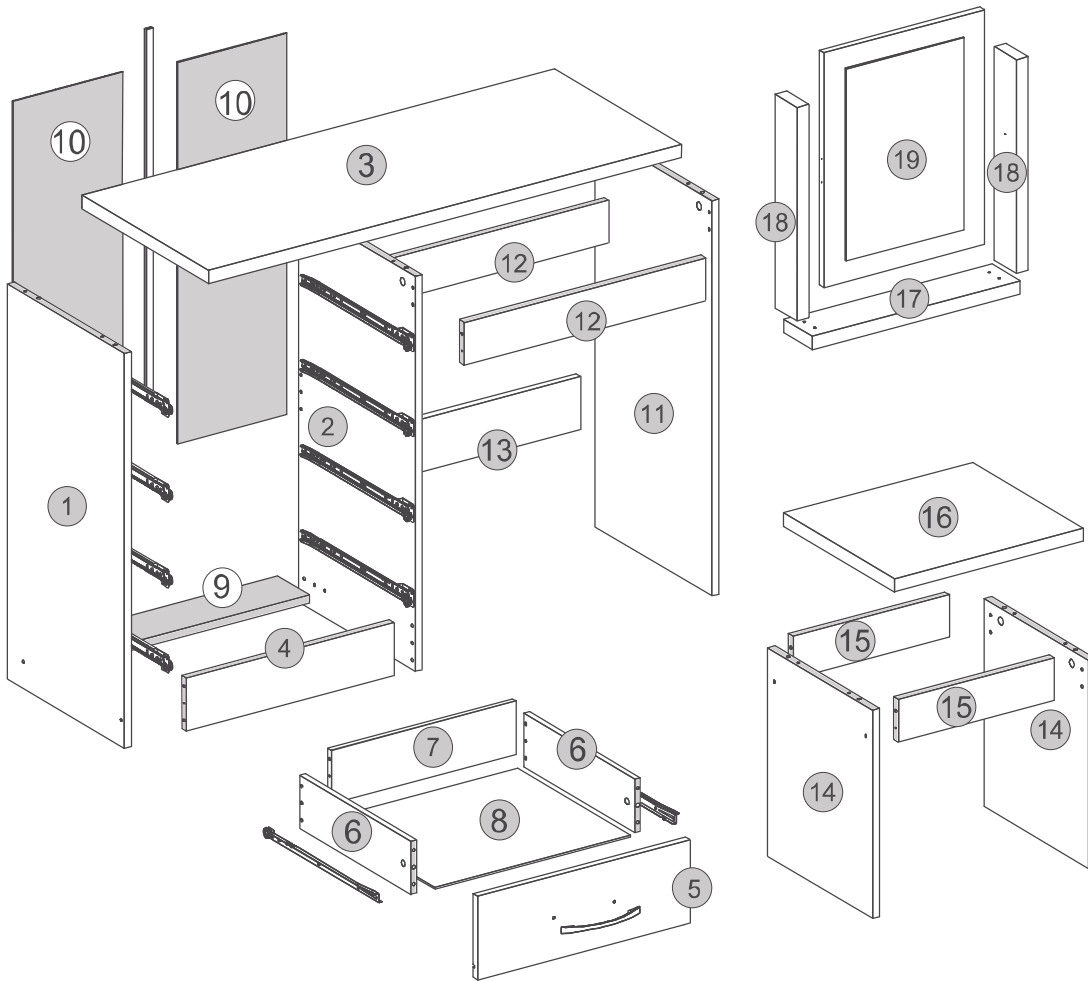

After assembly use an alcohol based product/cleaner to erase the numbers printed on the parts that are visual.

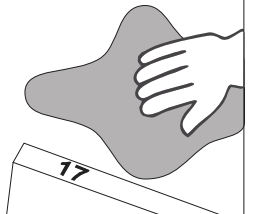



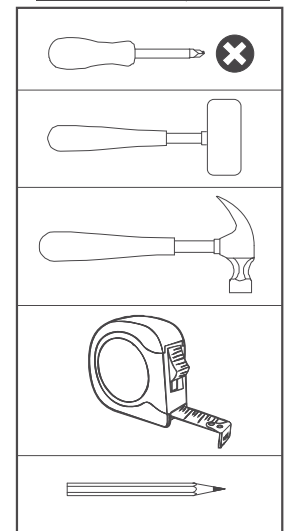









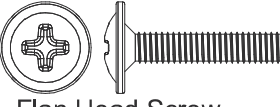

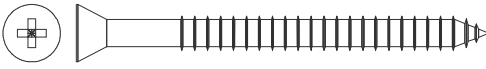
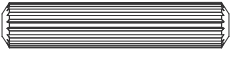
TOOLS REQUIRED

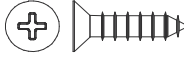
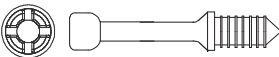
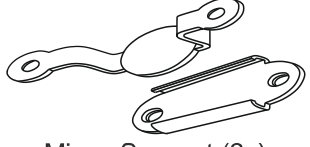
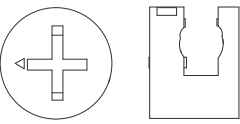
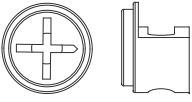
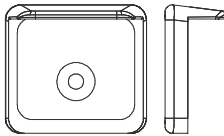

Please Note:
The below parts have all been stamped with the part number to help identify them during assembly.

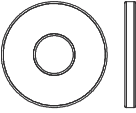
Part Number	Part Description	Quantity	Carton
01	Left Chest Side Panel	1	1/2
02	Right Chest Side Panel	1	1/2
03	Top Panel	1	2/2
04	Front Baseboard	1	1/2
05	Drawer Front	4	1/2
06	Drawer Side	8	2/2
07	Drawer Back	4	2/2
08	Drawer Bottom	4	2/2
09	Back Baseboard	1	1/2
10	Back Panel	2	1/2
11	Right Table Side Panel	1	1/2
12	Upper Crossbar	2	1/2
13	Back Crossbar	1	1/2
14	Stool Side Panel	2	2/2
15	Stool Crosspiece	2	2/2
16	Stool Seat	1	2/2
17	Mirror Base Panel	1	1/2
18	Mirror Side Panel	2	2/2
19	Mirror Panel	1	2/2

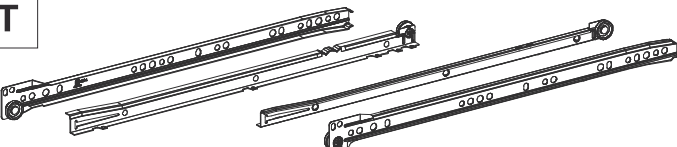
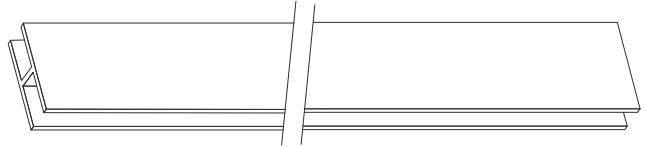
FITTINGS LIST

<p>A</p>  <p>Flat Head Screw Ø4,0 x 14mm (24x)</p> <p>+/2</p>	<p>B</p>  <p>Flat Head Screw Ø6,0 x 10mm (16x)</p> <p>+/2</p>	<p>C</p>  <p>Flan Head Screw Ø4,0 x 20mm (8x)</p> <p>+/1</p>	<p>D</p>  <p>Flan Head Screw Ø3,5 x 30mm (2x)</p> <p>+/1</p>
<p>E</p>  <p>Flat Head Screw Ø4,0x 50mm (22x)</p> <p>+/2</p>	<p>F</p>  <p>Flat Head Screw Ø4,5x 60mm (4x)</p> <p>+/1</p>	<p>G</p>  <p>+/2 Dowel Ø6,0 x 30mm (62x)</p>	
<p>H</p>  <p>+/2 Nail 10x10 Ringed -1,5x23mm (64x)</p>	<p>I</p>  <p>Flat Head Screw Black Ø3,0 x 16mm (8x)</p> <p>+/1</p>	<p>J</p>  <p>+/2 Cam Bolt (18x)</p>	<p>K</p>  <p>Mirror Support (2x)</p>
<p>L</p>  <p>+/2 Cam Nut Ø14,9x11mm (10x)</p>	<p>M</p>  <p>+/1 Cam Nut Ø12x8,8mm (8x)</p>	<p>N</p>  <p>+/2 Plastic Foot L 19x17x8mm Ø2 (10x)</p>	<p>O</p>  <p>+/2 Hole Plugs 19mm (22x)</p>
<p>P</p>  <p>Glue 10Gr (3x)</p>	<p>Q</p>  <p>Strap 200x20x1mm (2x)</p>	<p>R</p>  <p>+/1 Washer Ø16x7mm(4x)</p>	<p>S</p>  <p>Handle (4x)</p>
<p>T</p>  <p>Drawer Runners 350mm (4x)</p>		<p>U</p>  <p>Back Panel Strip H 683mm (1x)</p>	
<p>V</p>  <p>+/2 Hole Plugs Lineo 19mm (22x)</p>			

TIPS FOR FITTINGS CAM-LOCKS

WHEN FITTING CAM NUT. ENSURE STARTING POSITION IS CORRECT BEFORE YOU INSERT CONNECTING CAM BOLT TURN CLOCKWISE UNTIL SECURE

✓



↑

CORRECT

✗



↑

WRONG

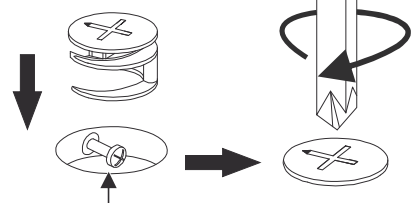

Cam bolt head needs to be in centre

CAMBOLT

Tighten until shoulder in flush with panel. Do not overtighten or undertighten (see example beside)

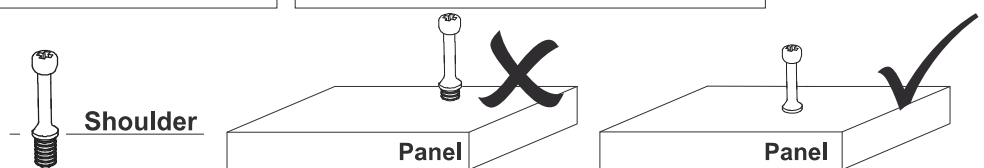



STEP 1

PARTS REQUIRED

4 - FRONT BASEBOARD	x1
9 - BACK BASEBOARD	x1
13- BACK CROSSBAR	x1
12 - UPPER CROSSBAR	x2
15 - STOOL CROSSPIECE	x2

HARDWARE REQUIRED

G		20
Ø6,0 x 30mm		
P		01
Glue		

TOOLS REQUIRED

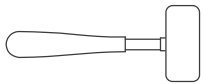

Detail 1

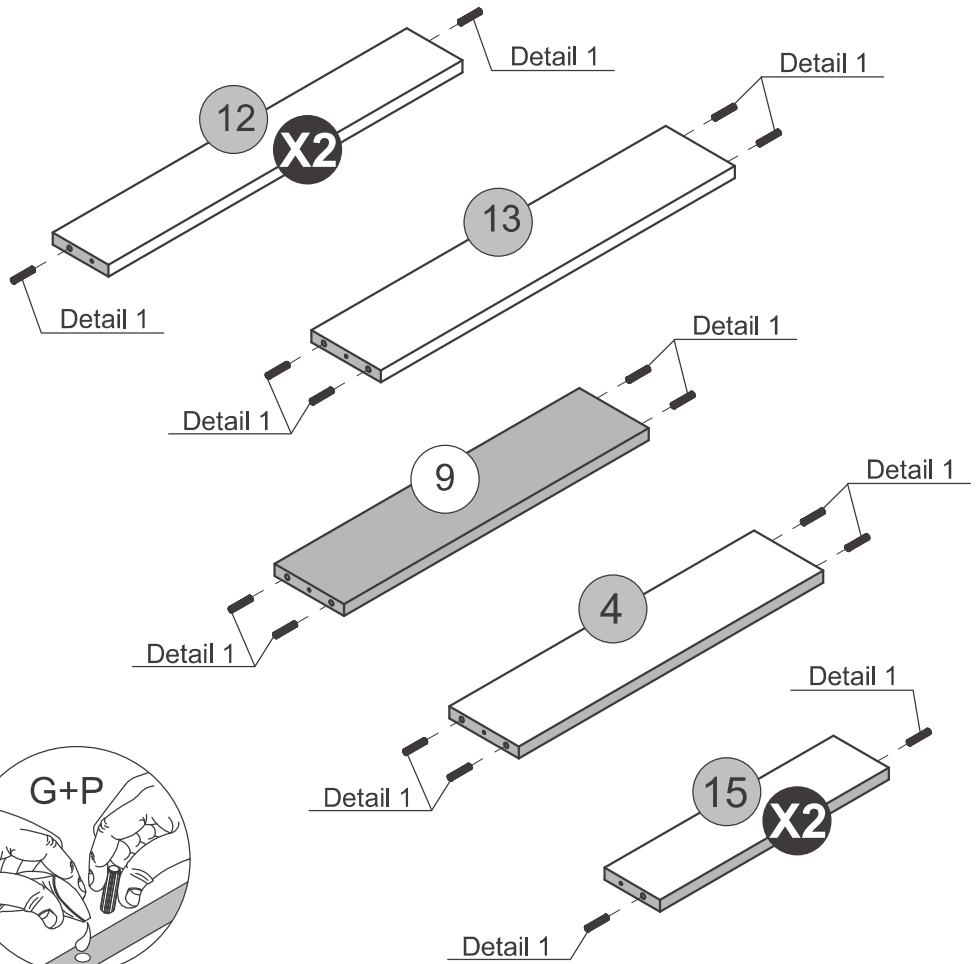

STEP 2

PARTS REQUIRED

3 - TOP PANEL	x1
16 - STOOL SEAT	x1

HARDWARE REQUIRED

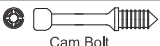
J		10
Cam Bolt		

TOOLS REQUIRED

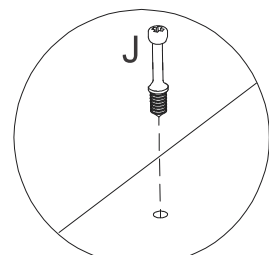

Detail 2

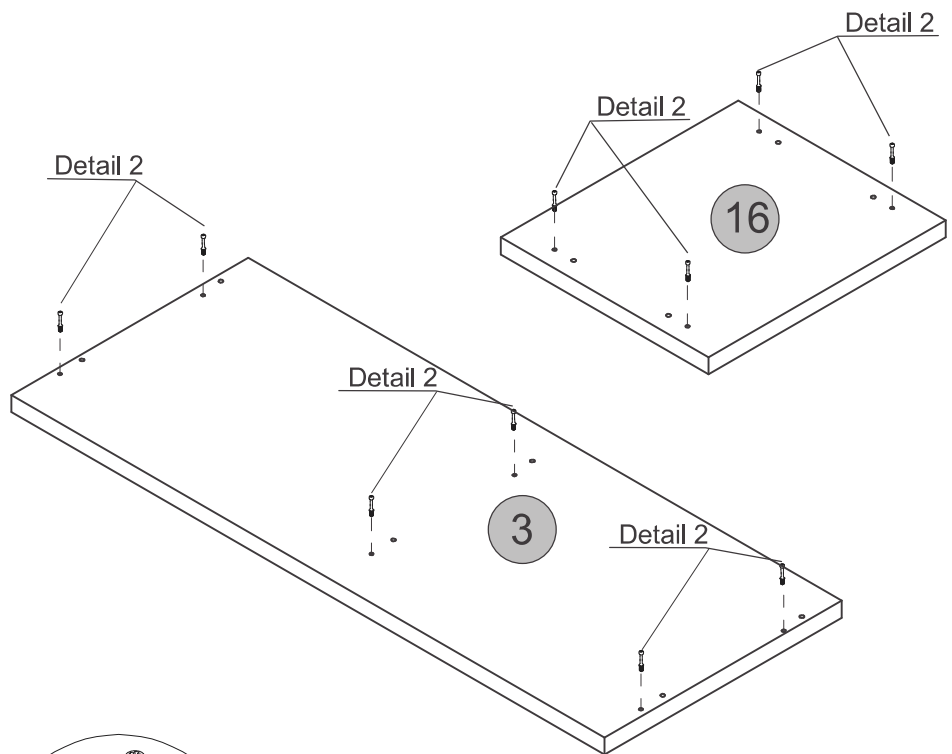
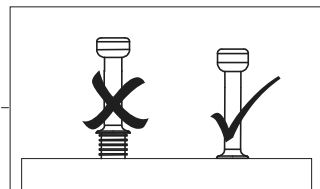

STEP 3

PARTS REQUIRED

2 - RIGHT CHEST SIDE PANEL x1

HARDWARE REQUIRED

A  04
Ø4,0 x 14mm

B  08
Ø6,0 x 10mm

G  02
Ø6,0 x 30mm

H  02

N  02

P  01

T  04
Right

TOOLS REQUIRED

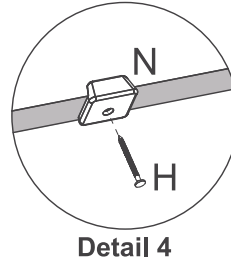
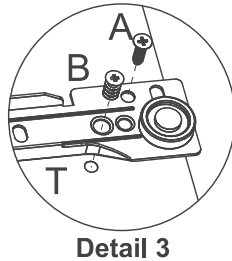
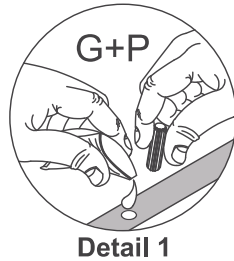
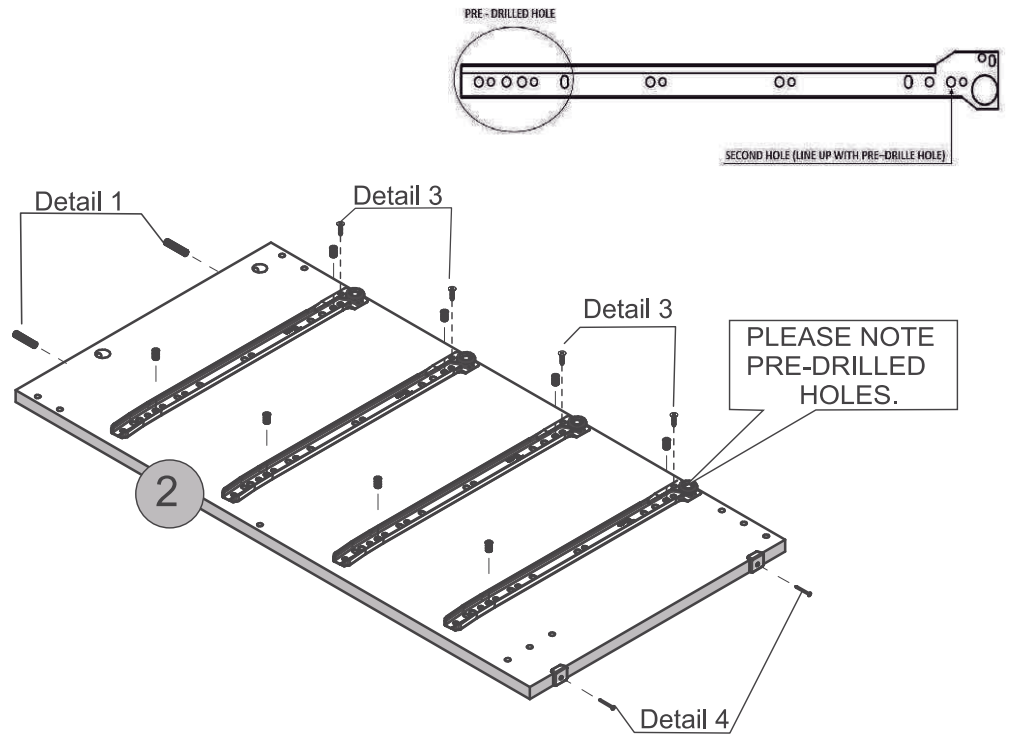
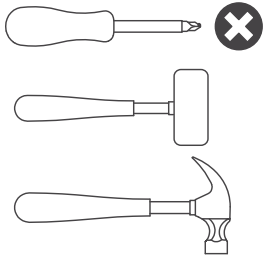

STEP 4

PARTS REQUIRED

1 - LEFT CHEST SIDE PANEL x1

HARDWARE REQUIRED

A  04
Ø4,0 x 14mm

B  08
Ø6,0 x 10mm

G  02
Ø6,0 x 30mm

H  02

N  02

P  01

T  04
Left

TOOLS REQUIRED

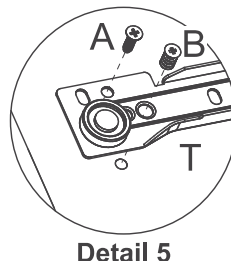
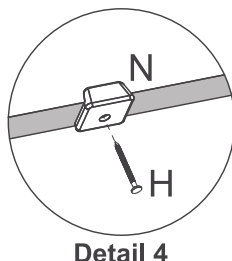
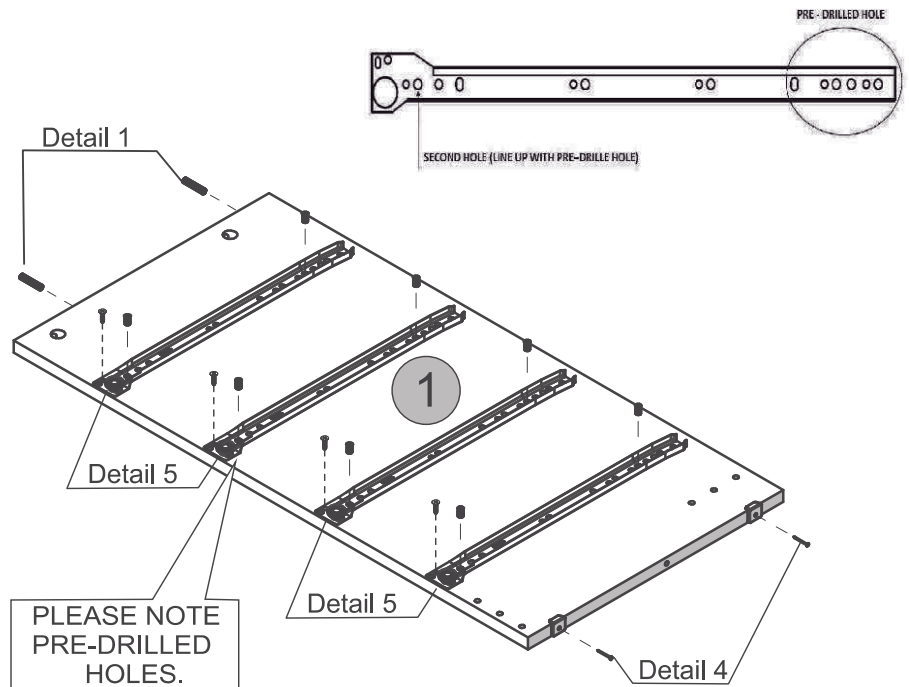
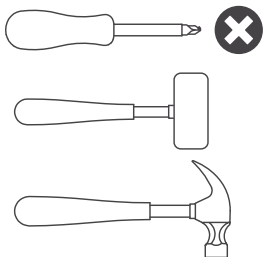

STEP 5

PARTS REQUIRED

11 - RIGHT TABLE SIDE PANEL x1

14 - STOOL SIDE PANEL x2

HARDWARE REQUIRED

G  06
Ø6,0 x 30mm

H  06

N  06

P  01

TOOLS REQUIRED

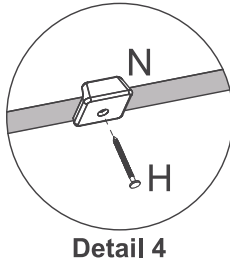
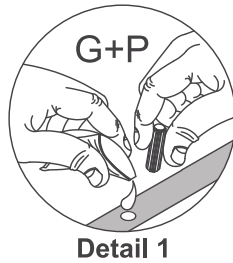
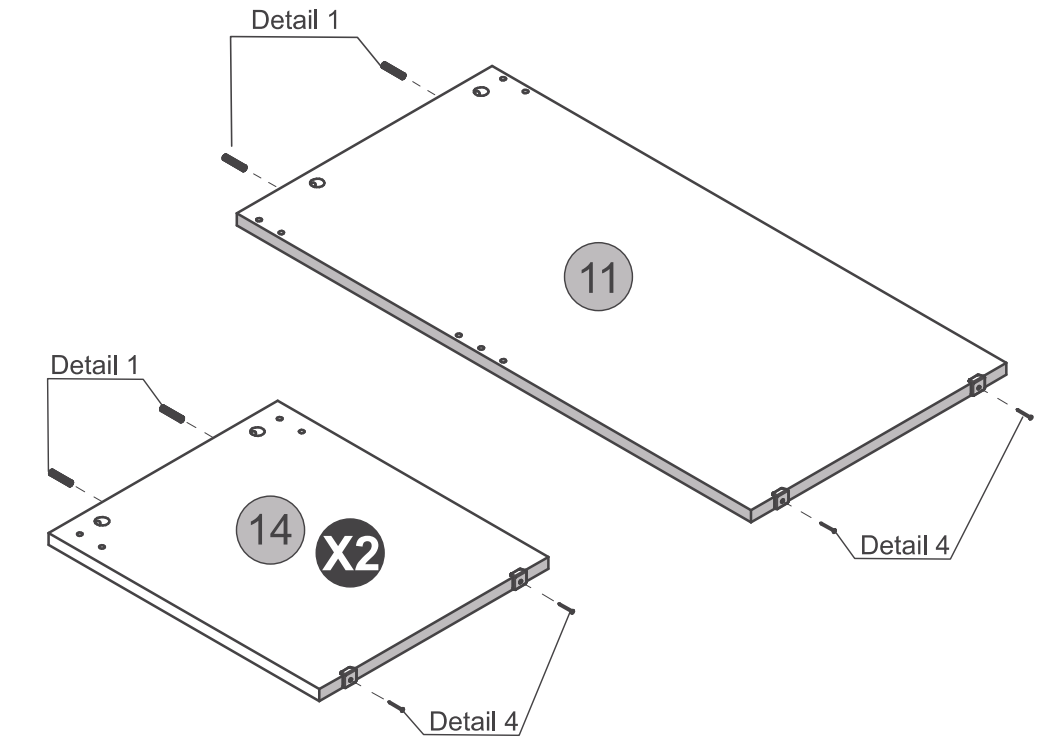
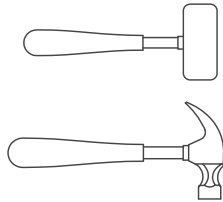

STEP 6

PARTS REQUIRED

1 - LEFT CHEST SIDE PANEL x1

2 - RIGHT CHEST SIDE PANEL x1

4 - FRONT BASEBOARD x1

9 - BACK BASEBOARD x1

HARDWARE REQUIRED

E  04
Ø4,0 x 50mm

P  01

TOOLS REQUIRED

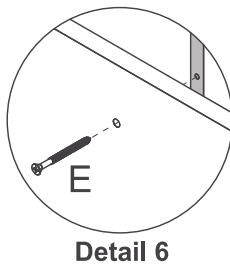
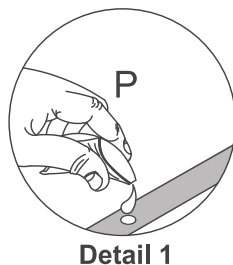
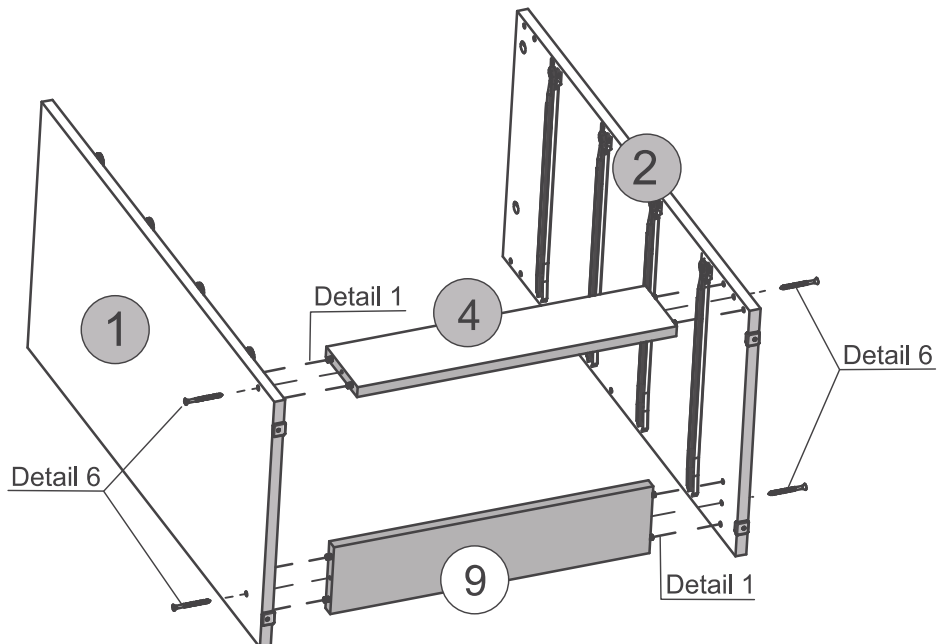
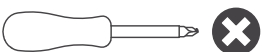

STEP 7

PARTS REQUIRED

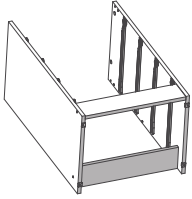

11 - RIGHT TABLE SIDE PANEL x1

12 - UPPER CROSSBAR x2

13 - BACK CROSSBAR x1

HARDWARE REQUIRED

E  06
Ø4,0 x 50mm

P  01

TOOLS REQUIRED

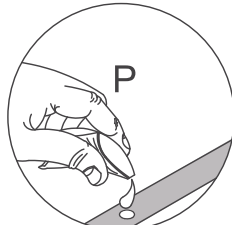
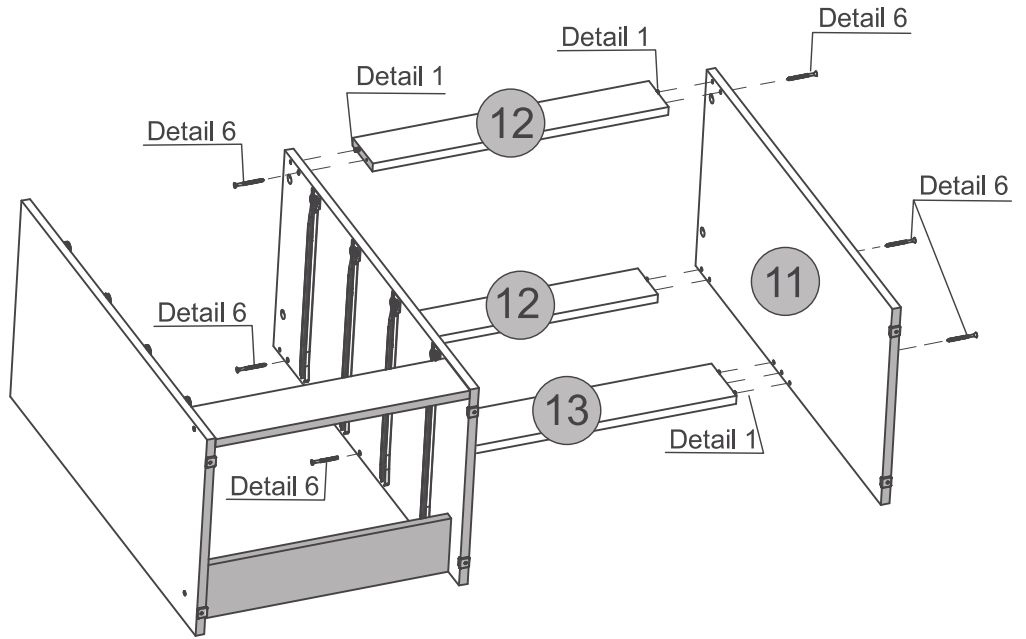
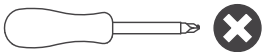

Detail 1

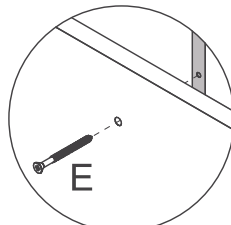

Detail 6

STEP 8

PARTS REQUIRED

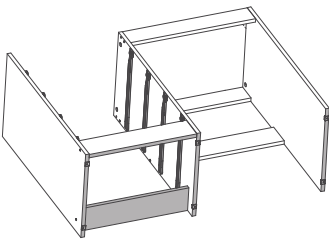

3 - TOP PANEL x1

HARDWARE REQUIRED

L  06

P  01

TOOLS REQUIRED

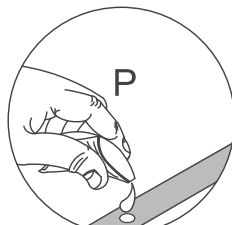
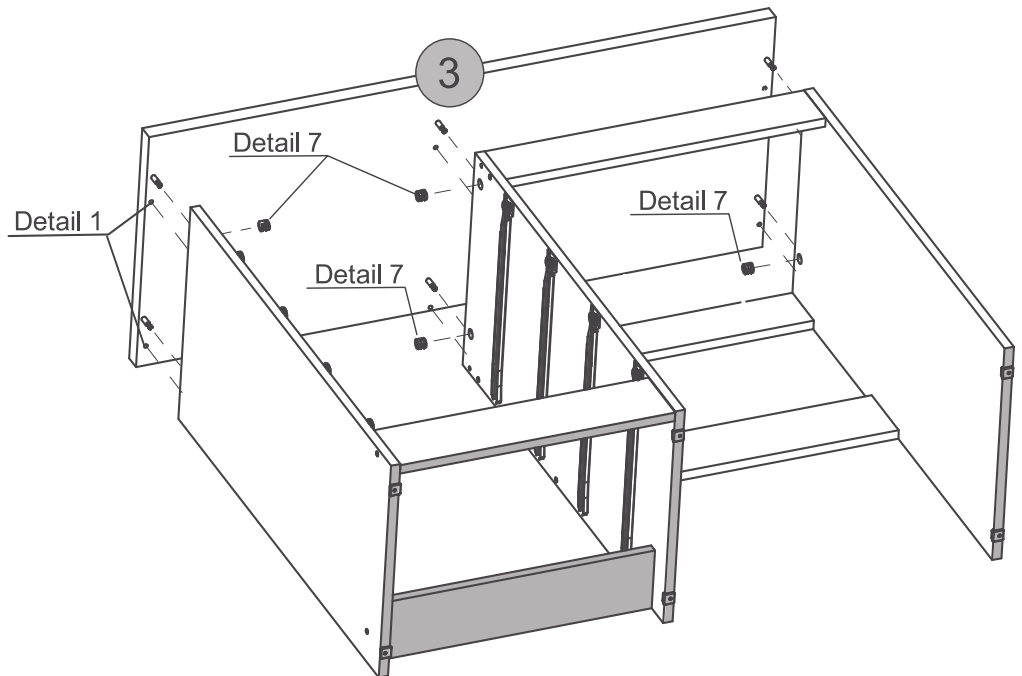

Detail 1

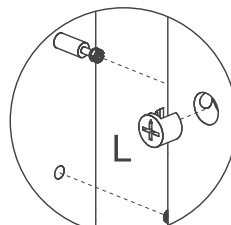

Detail 7

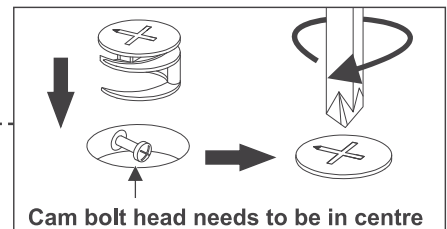

STEP 9

PARTS REQUIRED

10 - BACK PANEL x2

HARDWARE REQUIRED

H  22
10 x 10

U  01

TOOLS REQUIRED

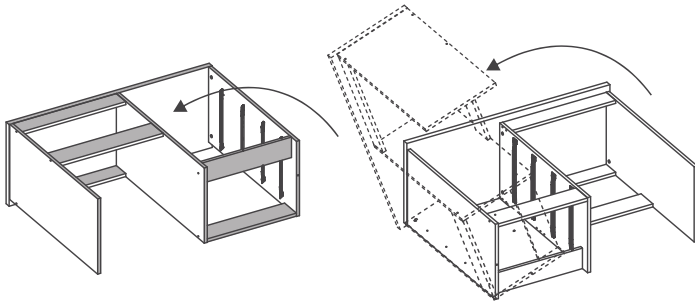
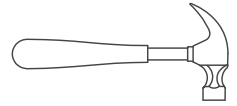

* For your future reference
Order Number should be here

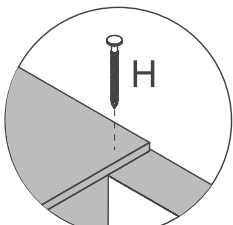
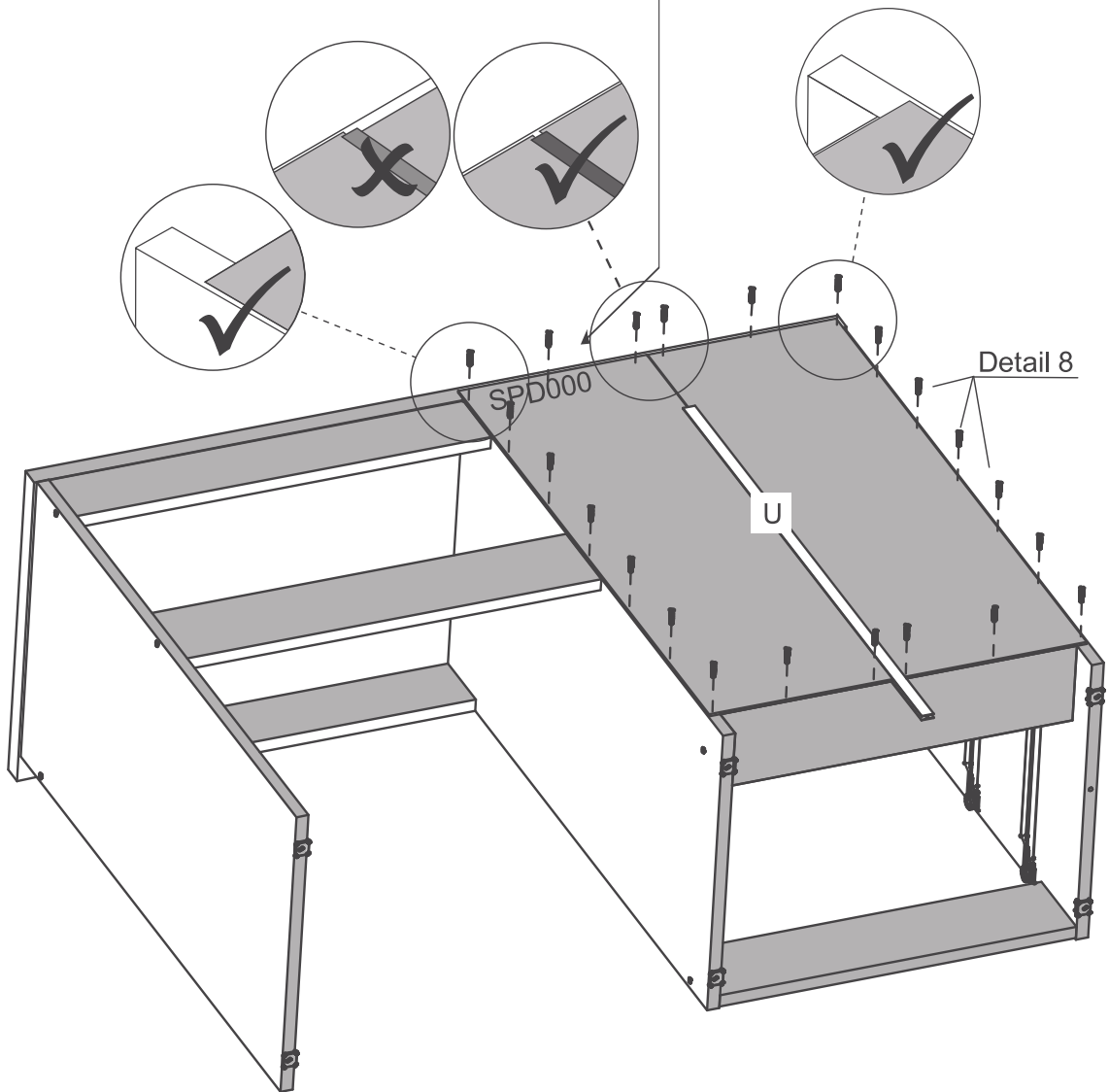

Detail 8

STEP 10

PARTS REQUIRED

5 - DRAWER FRONT x4

HARDWARE REQUIRED

J  08

TOOLS REQUIRED

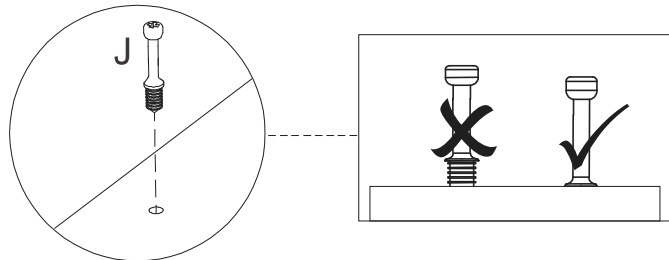
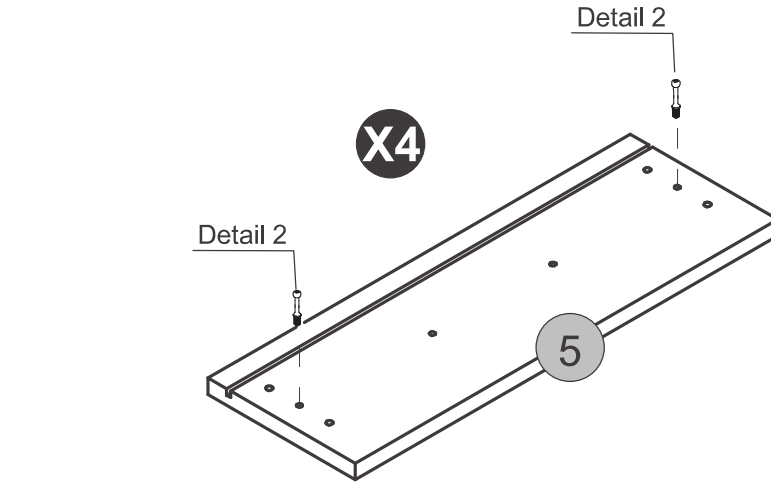

Detail 2

STEP 11

PARTS REQUIRED

6 - DRAWER SIDE x8

7 - DRAWER BACK x4

HARDWARE REQUIRED

G  32
Ø6,0 x 30mm

P  01

TOOLS REQUIRED

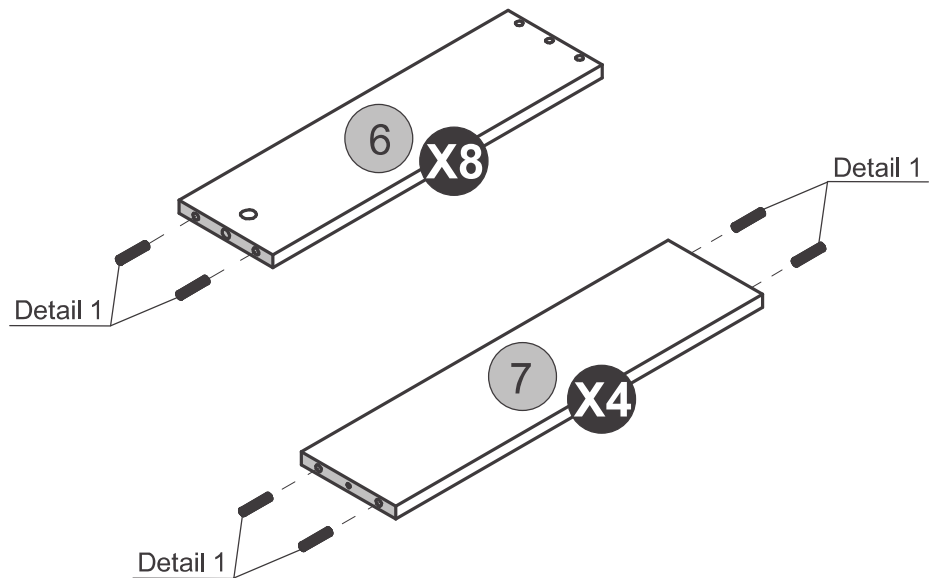
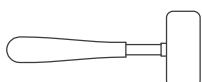



Detail 1

STEP 12

PARTS REQUIRED

6 - DRAWER SIDE	x8
7 - DRAWER BACK	x4

HARDWARE REQUIRED

E			08
Ø4,0 x 50mm			
P		01	

TOOLS REQUIRED

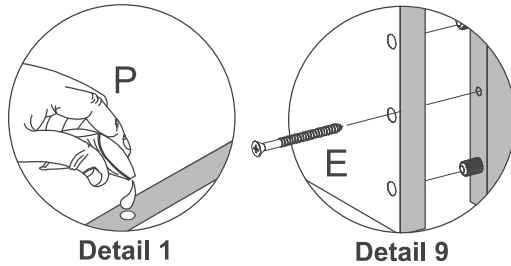
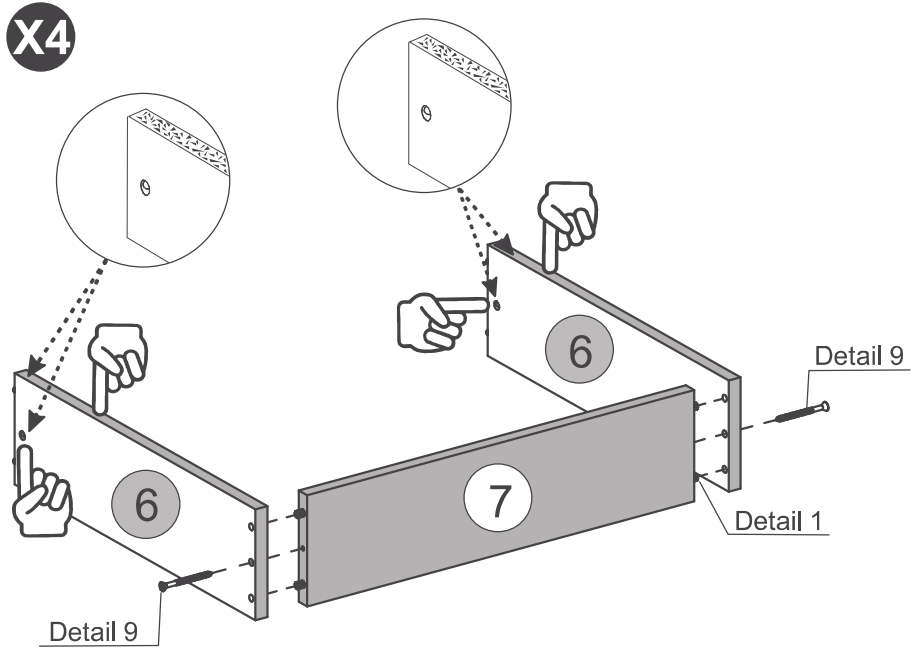
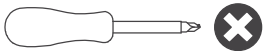



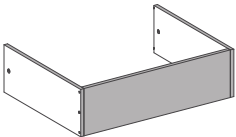

STEP 13

PARTS REQUIRED



5 - DRAWER FRONT	x4
------------------	----

HARDWARE REQUIRED

M			08
V		08	
P		01	

TOOLS REQUIRED

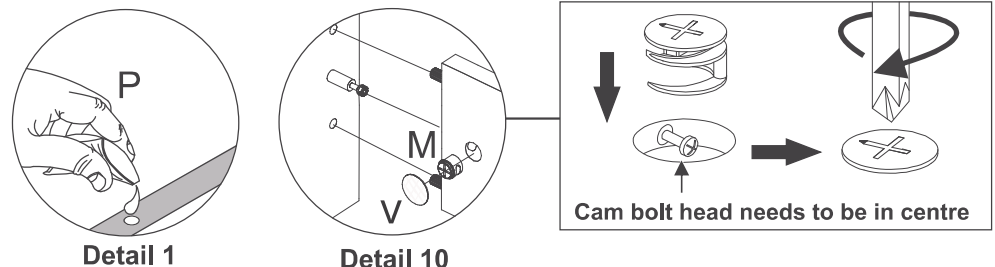
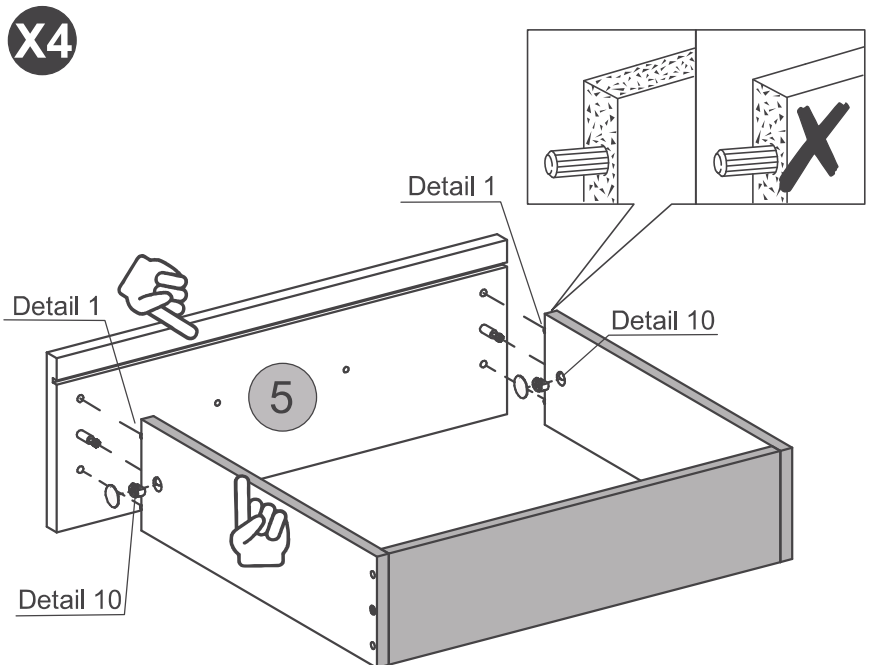

STEP 14

PARTS REQUIRED

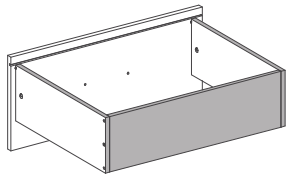

8 - DRAWER BOTTOM x4

HARDWARE REQUIRED

H  32
10 x 10

TOOLS REQUIRED

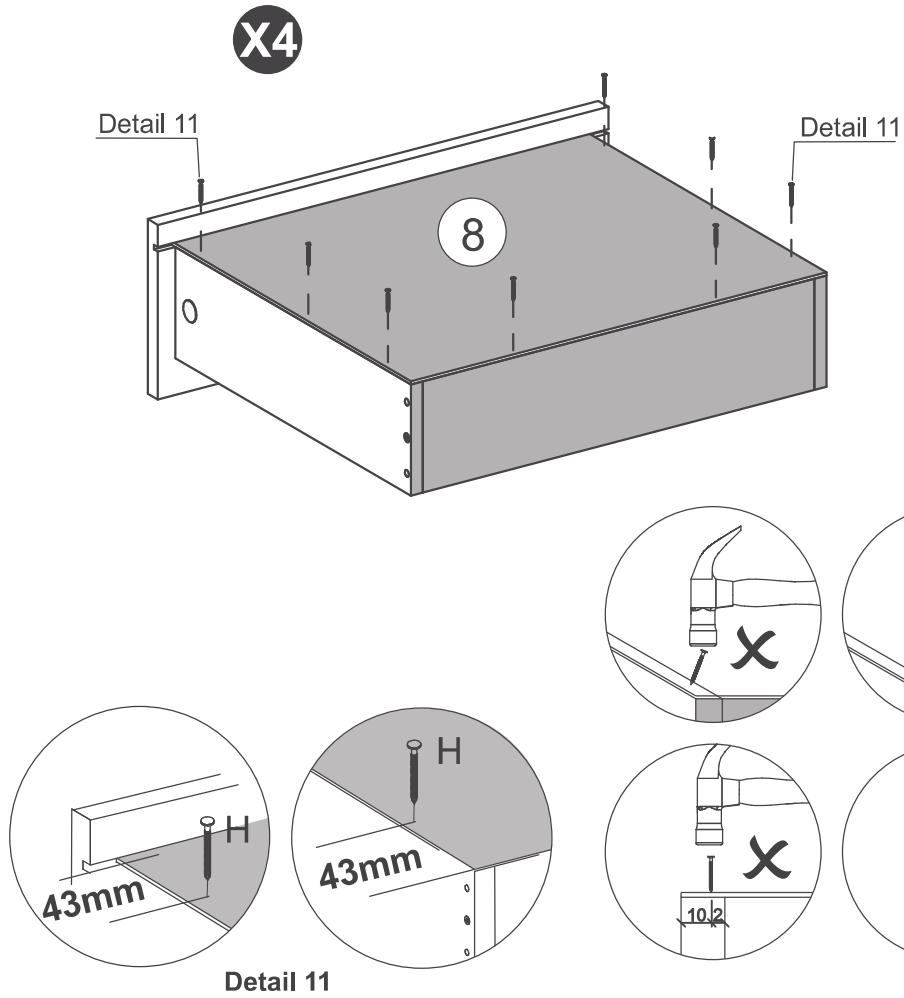
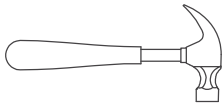

STEP 15

PARTS REQUIRED

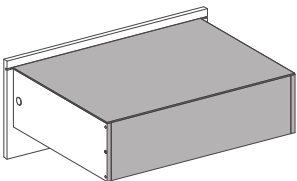

HARDWARE REQUIRED

A  16
Ø4,0 x 14mm

T LEFT 04

T RIGHT 04

TOOLS REQUIRED

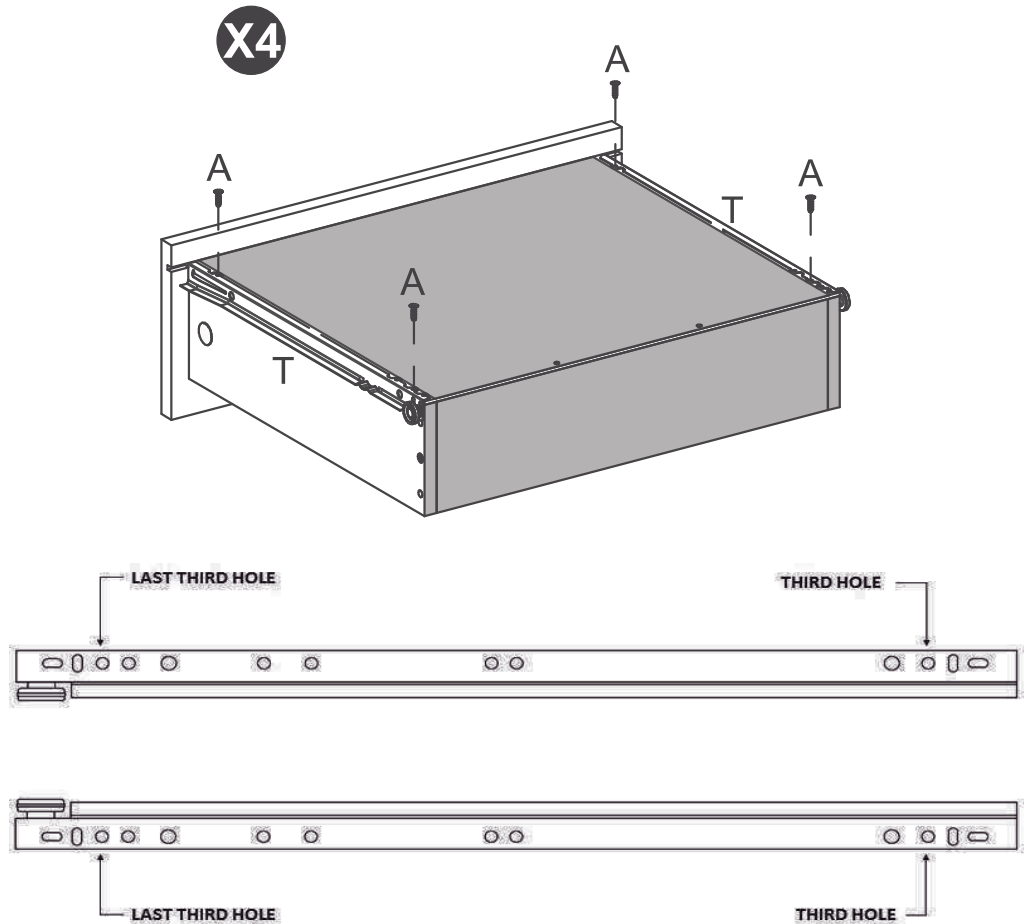

STEP 16

PARTS REQUIRED

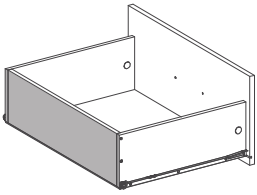

HARDWARE REQUIRED



TOOLS REQUIRED

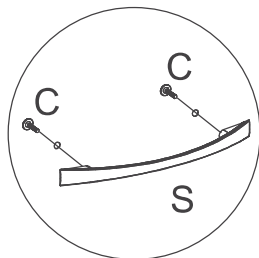
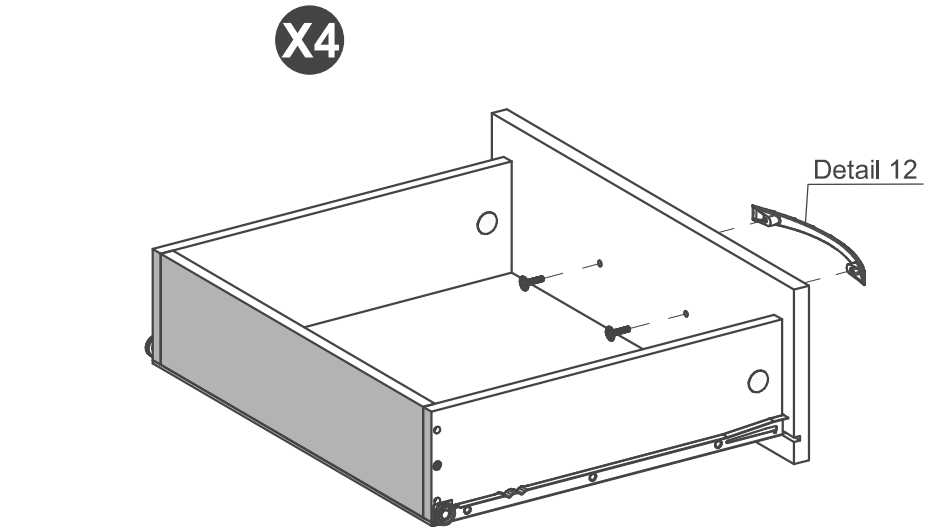
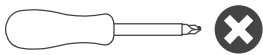

Detail 12

STEP 17

PARTS REQUIRED



HARDWARE REQUIRED

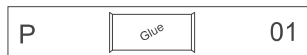
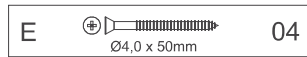

TOOLS REQUIRED

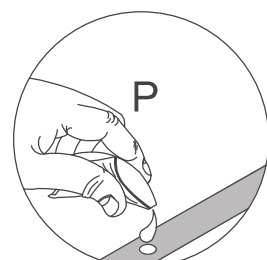
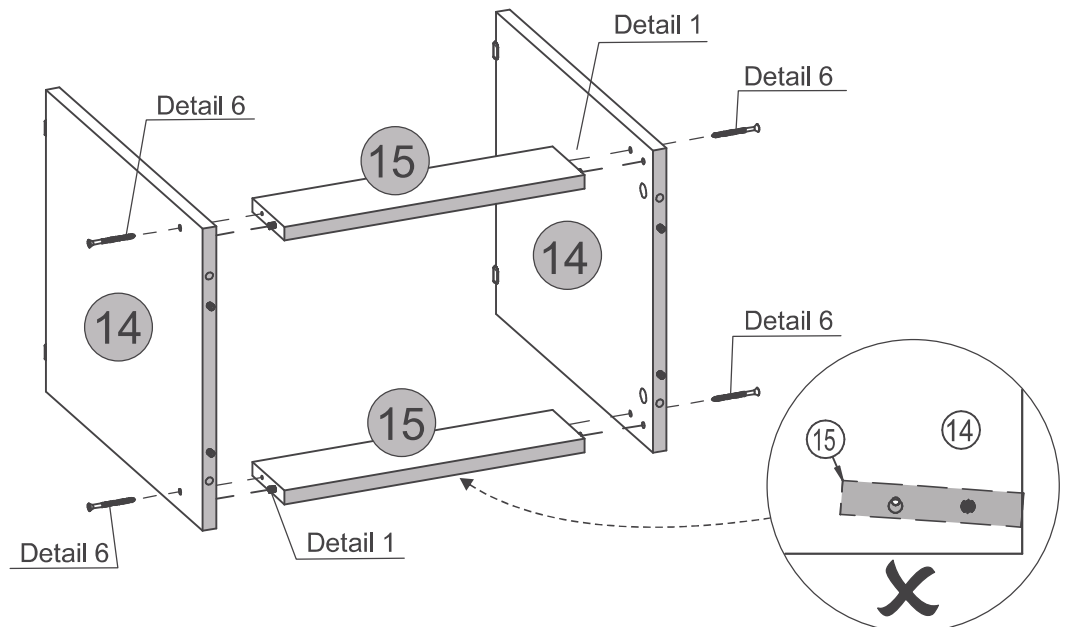

Detail 1

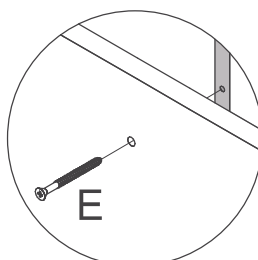

Detail 6

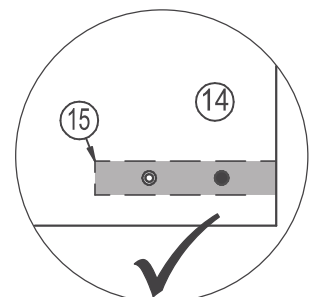

STEP 18

PARTS REQUIRED

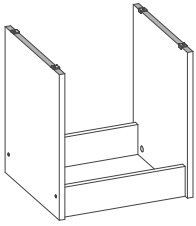

16 - STOOL SEAT x1

HARDWARE REQUIRED

L  04

P  01

TOOLS REQUIRED

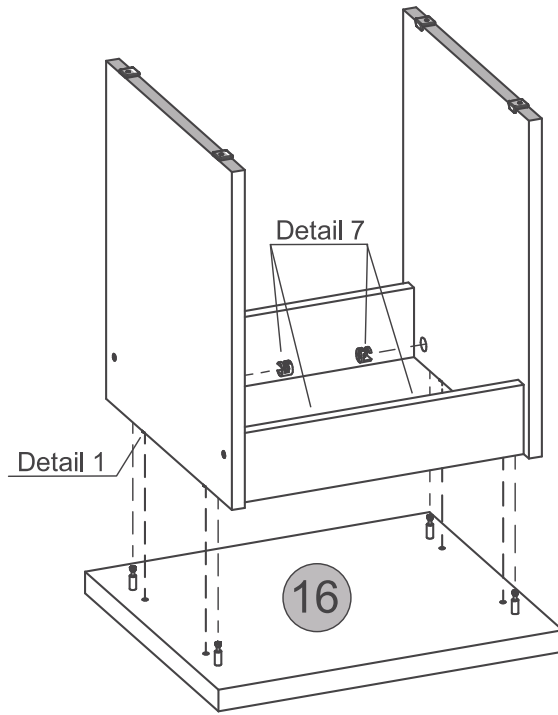
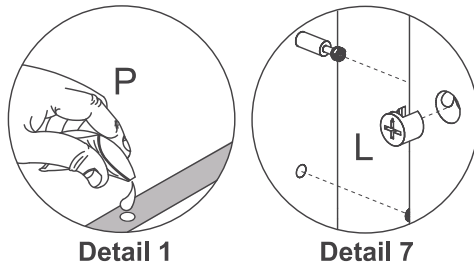

STEP 19

PARTS REQUIRED

17 - MIRROR BASE PANEL x1

18 - MIRROR SIDE PANEL x2

HARDWARE REQUIRED

F  04
Ø4,5 x 60mm

I  04
Ø3,0 x 16mm

K  02

TOOLS REQUIRED

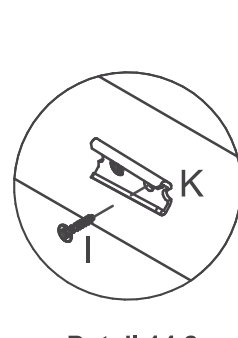
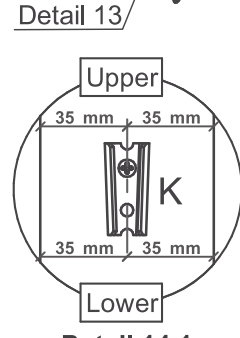
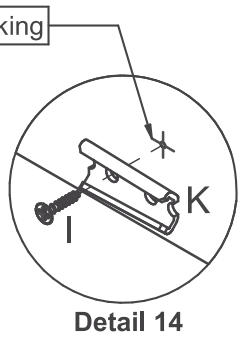
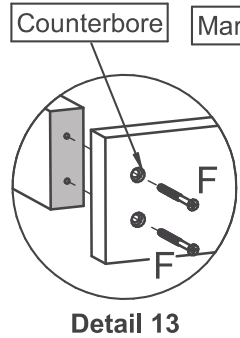
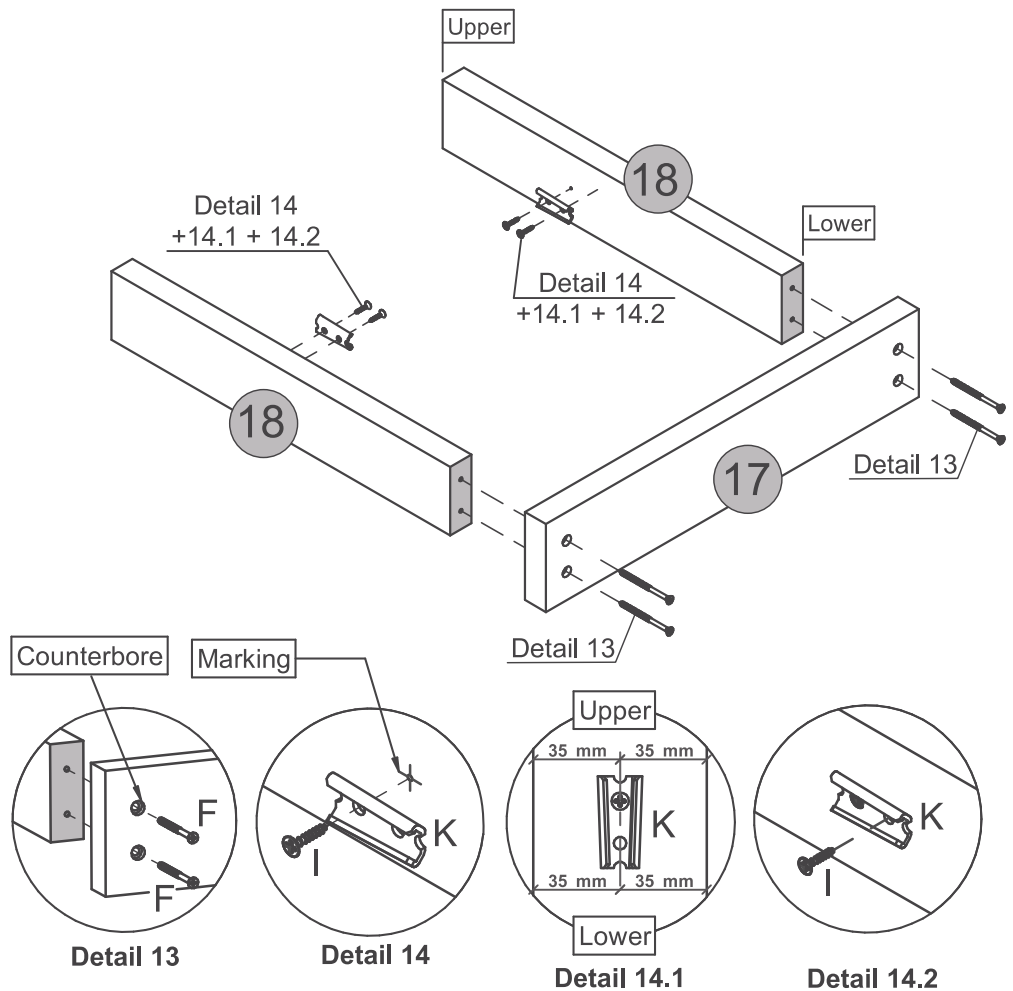

STEP 20

PARTS REQUIRED

19 - MIRROR PANEL x1

HARDWARE REQUIRED

I  04
Ø3,0 x 16mm

K  02

TOOLS REQUIRED

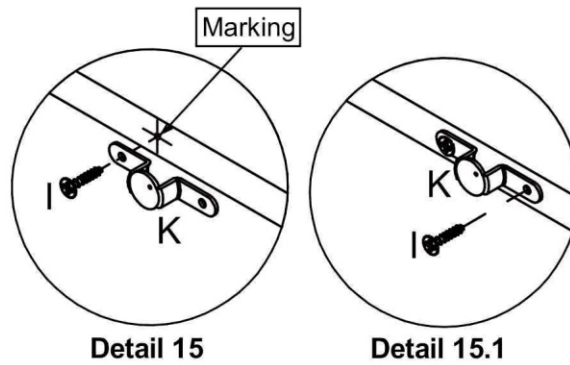
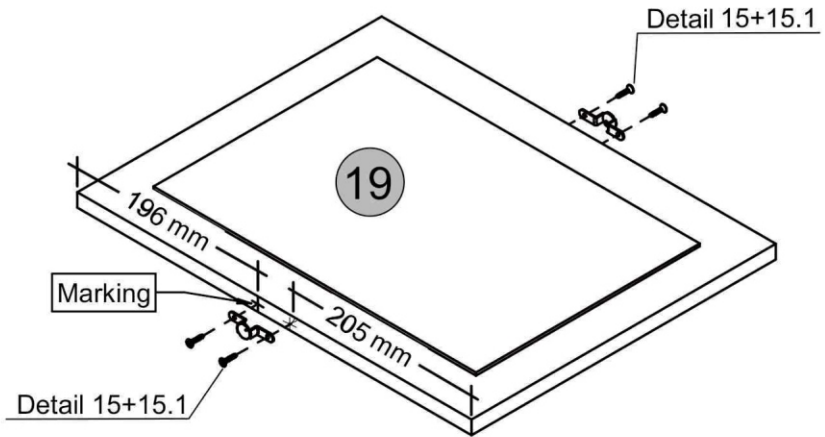
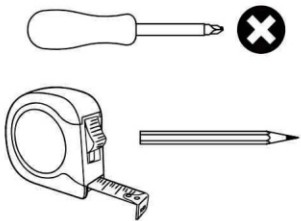

STEP 21

PARTS REQUIRED

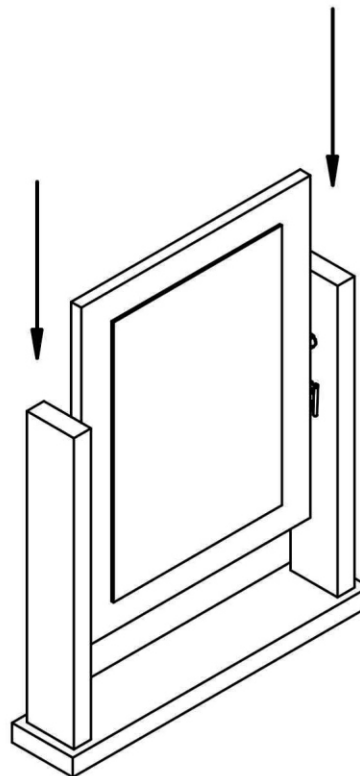
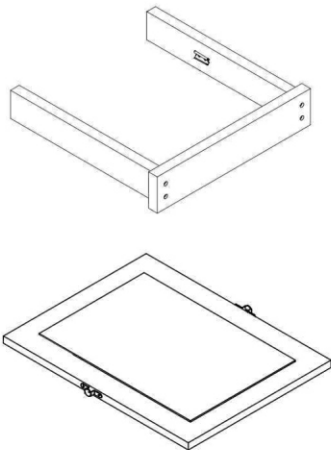

STEP 22

PARTS REQUIRED

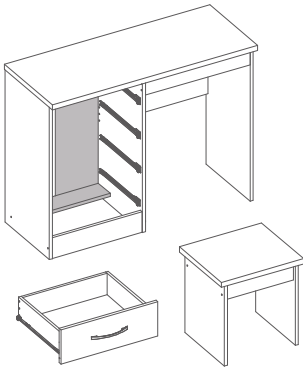

HARDWARE REQUIRED



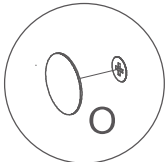
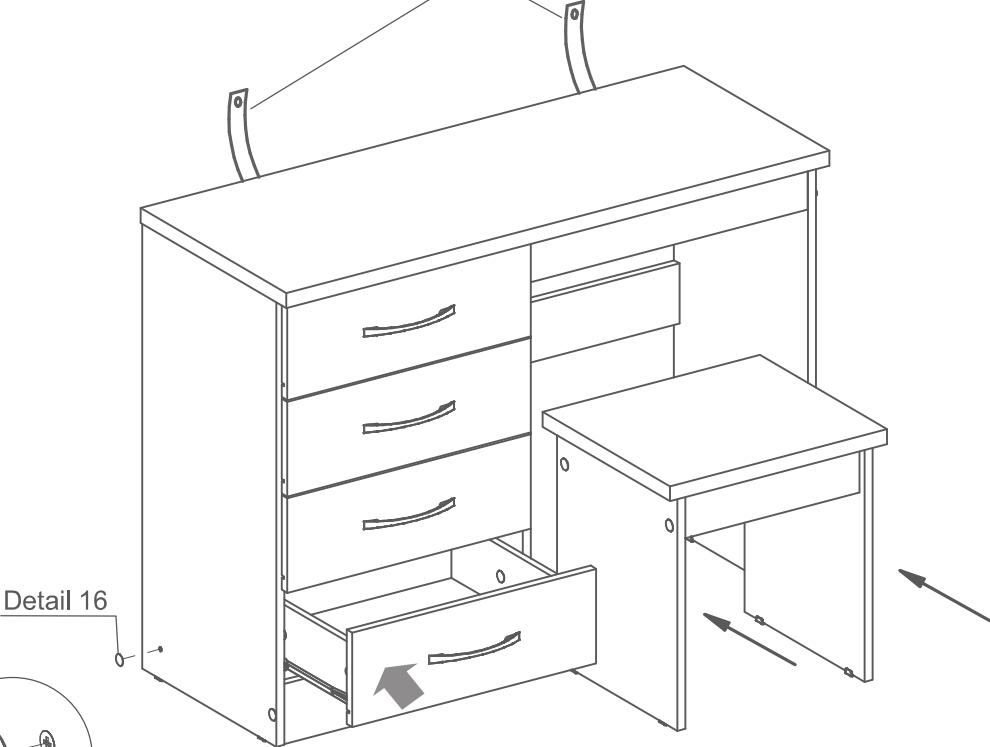

See the last page

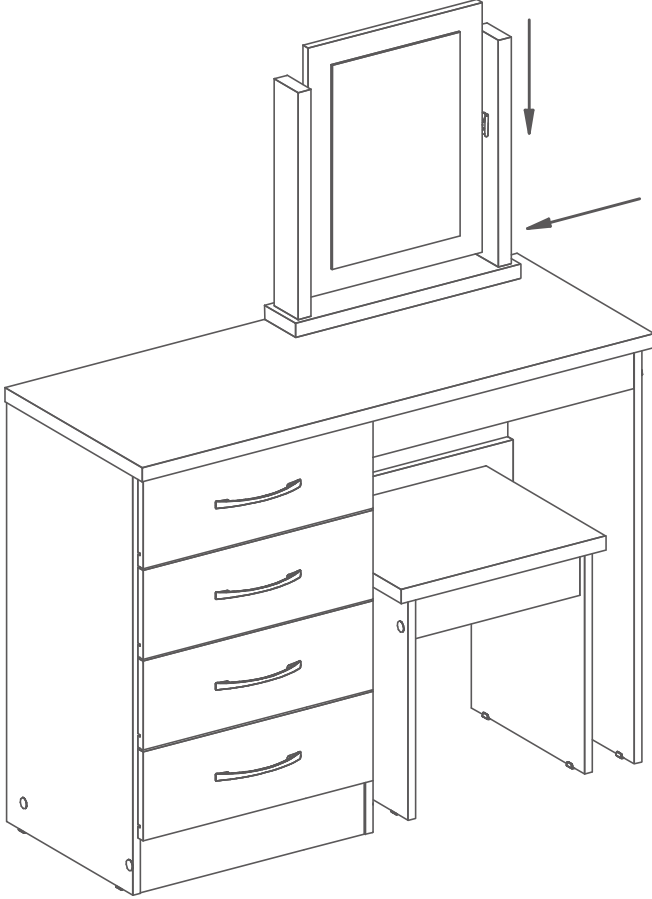
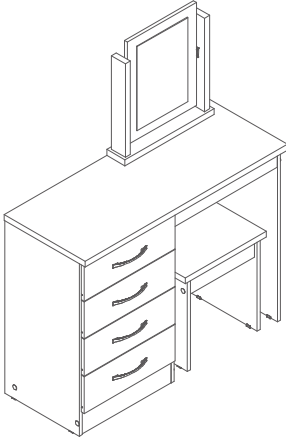

Detail 16

STEP 23



WARNING

Serious or fatal injuries can occur from furniture tipping over. To prevent the furniture from tipping over we recommend that it is permanently fixed to the wall.

Wall fixings are not supplied with this product as different wall materials require different types of fixing devices.

Please make sure you use fixings suitable for the walls in your home.

