

# NEVADA 4 DOOR 2 DRAWER WARDROBE ASSEMBLY INSTRUCTIONS

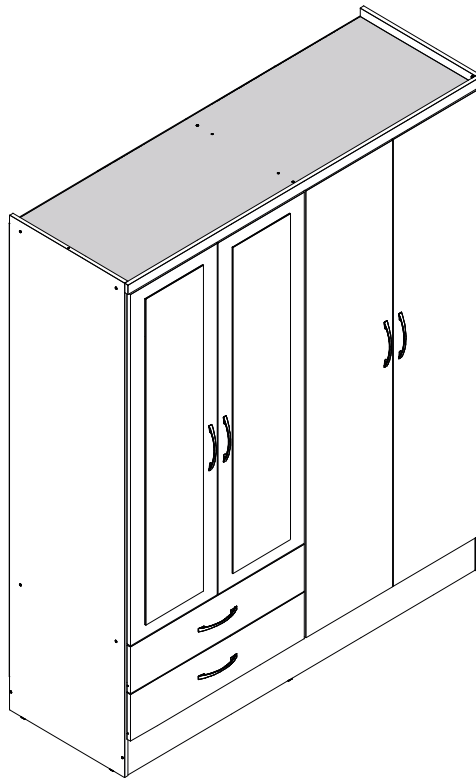

## **IMPORTANT FOR DOMESTIC USE ONLY PLEASE READ BEFORE YOU CONTINUE FURTHER CARE AND MAINTENANCE**

After unpacking this product please keep the original packaging in case it needs to be returned for any reason.

- Please ensure all fittings and parts are present before commencing with assembly.
- Never drag or push products as this could cause damage to the joints making it inferior.
- We strongly recommend that you keep children away from your work area.
- We recommend that you lay a blanket or sheet on the floor to avoid damage to both your floor and the product.
- Assemble this product as close to its final position as possible.
- Do not place this product next to a radiator or in direct sunlight.
- Do not drag or push items across your high gloss furniture as this may cause the surface to scratch
- Wood is a natural product and may expand if subjected to damp and may shrink or crack if subjected to heat. Therefore it is recommended that room temperature is maintained, with no sudden temperature fluctuations.
- Make sure any spillage is wiped off immediately.
- Do not place hot or chilled items directly on to the surface, use a place mat or marking will occur.
- For general cleaning use a soft cotton or micro fibre cloth, and do not use detergents of any kind.
- From time to time it may be necessary to tighten fittings, regular inspections should be carried out.
- Do not place on a wet or damp floor as staining may occur to your floor.

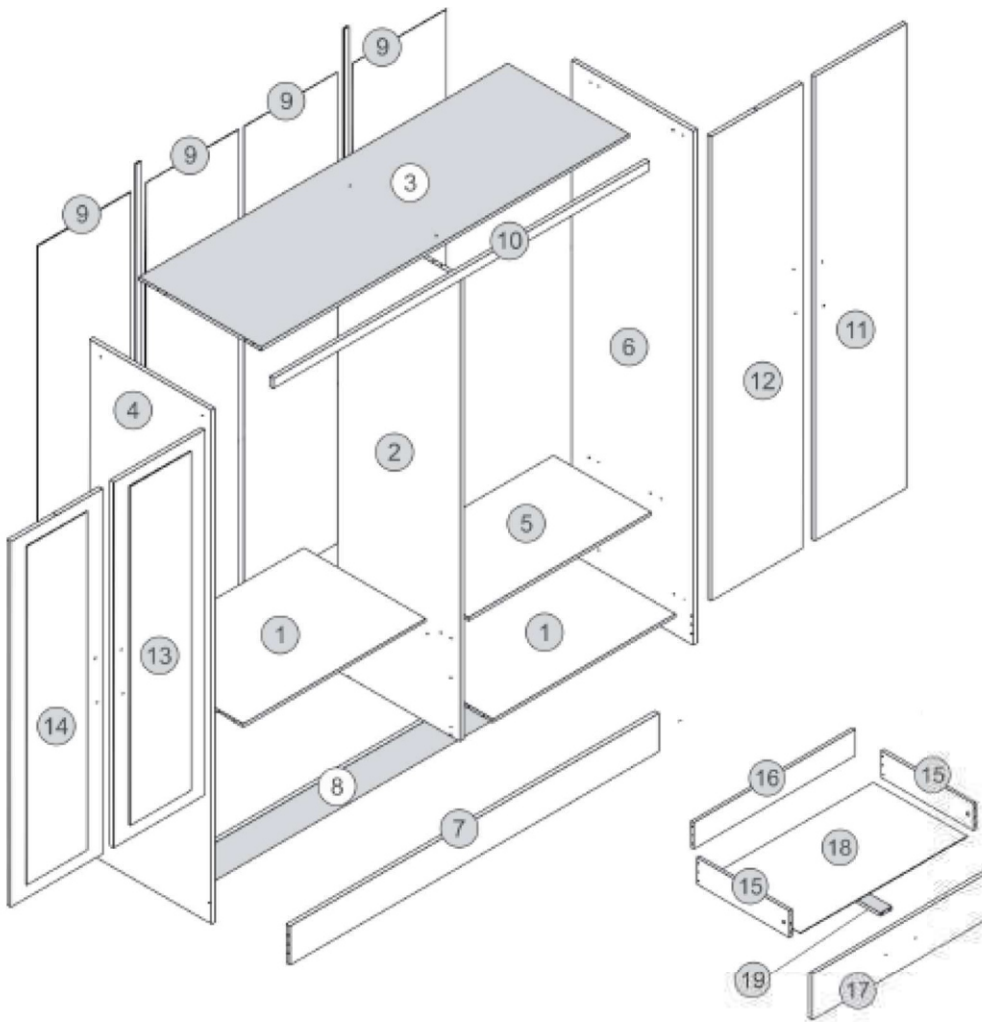

After assembly use an alcohol based product/cleaner to erase the numbers printed on the parts that are visual.

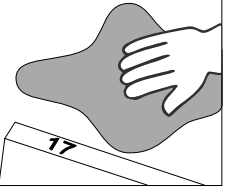

#### TOOLS REQUIRED

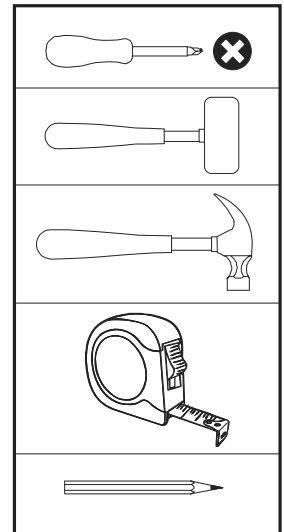







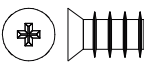
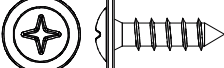
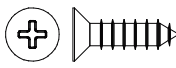
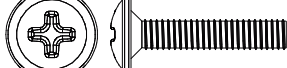
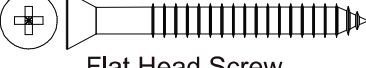
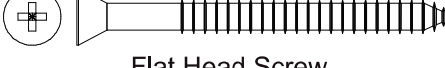

#### ***Please Note:***

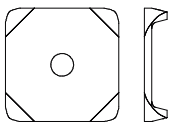
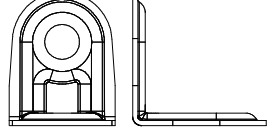
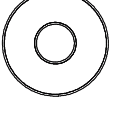
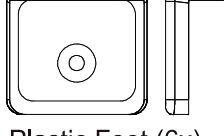
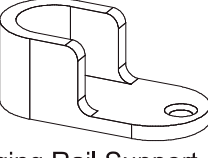
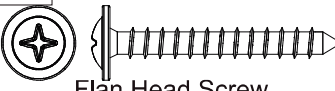
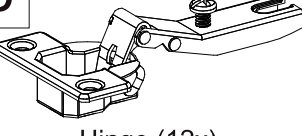
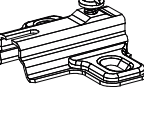
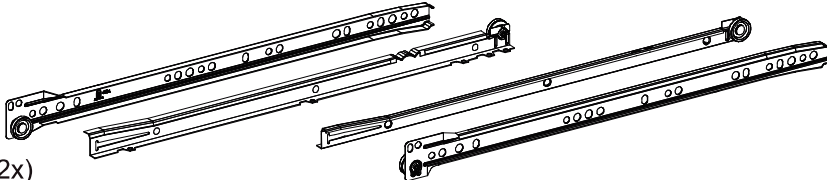
The below parts have all been stamped with the part number to help identify them during assembly.

<b>Part Number</b>	<b>Part Description</b>	<b>Quantity</b>	<b>Carton</b>
01	Base Panel	2	1/3
02	Division Panel	1	2/3
03	Top Panel	1	2/3
04	Left Side Panel	1	1/3
05	Shelf	1	1/3
06	Right Side Panel	1	1/3
07	Front Baseboard	1	2/3
08	Back Baseboard	1	2/3
09	Back Panel	4	2/3
10	Frame	1	2/3
11	Right Large Door	1	3/3
12	Left Large Door	1	3/3
13	Right Small Door	1	3/3
14	Left Small Door	1	3/3
15	Drawer Side	4	1/3
16	Drawer Back Panel	2	1/3
17	Drawer Front	2	2/3
18	Drawer Bottom	2	2/3
19	Drawer Bottom Support Bar	2	2/3

### FITTINGS LIST

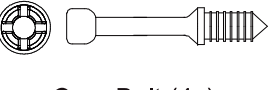
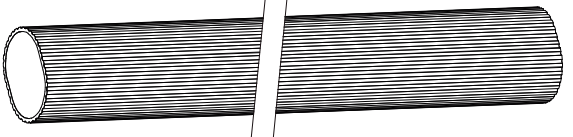
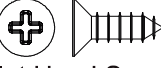
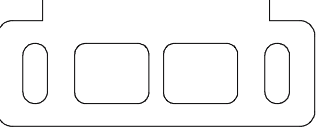
<p><b>A</b></p>  <p>Flat Head Screw Ø6,0 x 10mm (8x)</p> <p>+/1</p>	<p><b>B</b></p>  <p>Flan Head Screw Ø4,0 x 14mm (12x)</p> <p>+/2</p>	<p><b>C</b></p>  <p>Flat Head Screw Ø4,0 x 14mm (68x)</p> <p>+/2</p>	<p><b>D</b></p>  <p>Flan Head Screw Ø4,0 x 20mm (12x)</p> <p>+/2</p>
<p><b>E</b></p>  <p>Flat Head Screw Ø3,5 x 40mm (4x)</p> <p>+/1</p>	<p><b>F</b></p>  <p>Flat Head Screw Ø4,0 x 50mm (26x)</p> <p>+/2</p>	<p><b>G</b></p>  <p>+/2 Dowel Ø6,0 x 30mm (46x)</p>	
<p><b>H</b></p>  <p>Nail 10 x 10 (100x)</p> <p>+/2</p>	<p><b>I</b></p>  <p>Back Panel Bracket (16x)</p> <p>+/2</p>	<p><b>J</b></p>  <p>'L' Metallic Support (10x)</p> <p>+/2</p>	<p><b>K</b></p>  <p>Washer (4x)</p> <p>+/1</p>
<p><b>L</b></p>  <p>Plastic Foot (6x)</p> <p>+/1</p>	<p><b>M</b></p>  <p>Hanging Rail Support (4x)</p>	<p><b>N</b></p>  <p>Flan Head Screw Ø3,5 x 30mm (2x)</p> <p>+/1</p>	<p><b>O</b></p>  <p>Hinge (12x)</p>
<p><b>P</b></p>  <p>Hinge Plate (12x)</p>	<p><b>Q</b></p>  <p>Drawer Runners (2x)</p>		
<p><b>R</b></p>  <p>Back Panel Strip (2x)</p>	<p><b>S</b></p>  <p>Strap (2x)</p>	<p><b>T</b></p>  <p>Handle (6x)</p>	
<p><b>U</b></p>  <p>Hole Plugs (14x)</p> <p>+/2</p>	<p><b>V</b></p>  <p>Glue (2x)</p>	<p><b>W</b></p>  <p>Cam Nut (4x)</p> <p>+/1</p>	<p><b>X</b></p>  <p>Cam Bolt (4x)</p> <p>+/1</p>
<p><b>Y</b></p>  <p>Hanging Rail (2x)</p>	<p><b>Z</b></p>  <p>Flat Head Screw Ø4,0 x 12mm (28x)</p> <p>+/2</p>	<p><b>A1</b></p>  <p>Door Support (4x)</p>	

### TIPS FOR FITTINGS CAM-LOCKS

WHEN FITTING CAM NUT. ENSURE STARTING POSITION IS CORRECT BEFORE YOU INSERT CONNECTING CAM BOLT TURN CLOCKWISE UNTIL SECURE

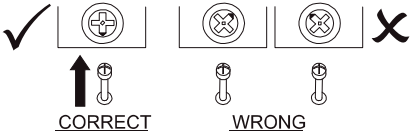

↑ CORRECT      ↓ WRONG

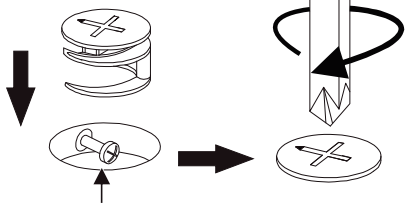

Cam bolt head needs to be in centre

**B1**



+/2 Hole Plugs Lineo 19mm (6x)

#### CAMBOLT

Tighten until shoulder in flush with panel. Do not overtighten or undertighten (see example beside)

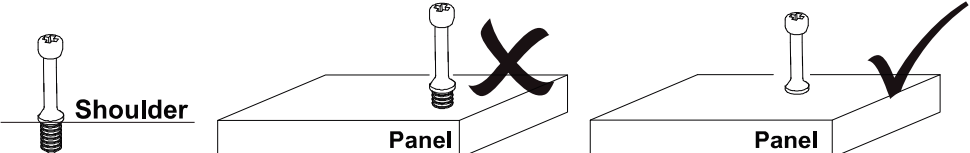

Shoulder      Panel      Panel

# STEP 1

## PARTS REQUIRED

4 - LEFT SIDE PANEL x1

## HARDWARE REQUIRED

C  08  
Ø4,0 x 14mm

H  02

L  02

M  01

P  03

## TOOLS REQUIRED

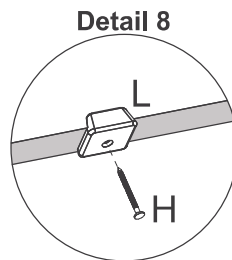
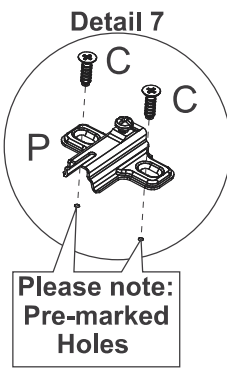
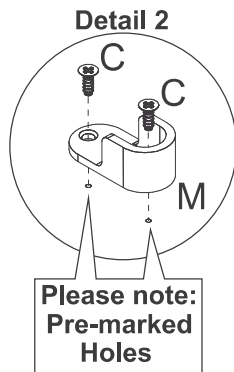
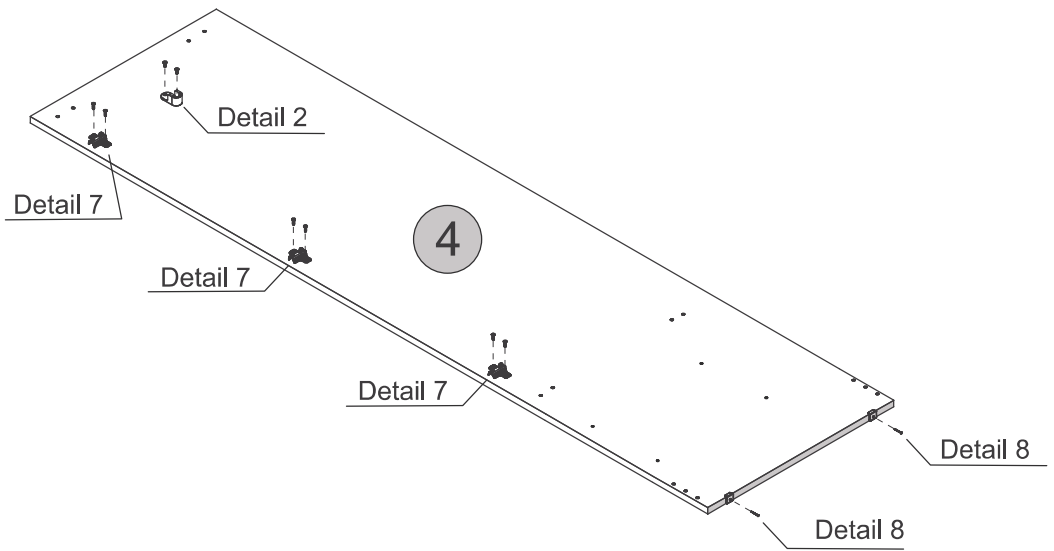
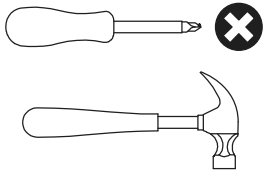

# STEP 2

## PARTS REQUIRED

4 - LEFT SIDE PANEL x1

## HARDWARE REQUIRED

A  04  
Ø6,0 x 10mm

Q  02  
Left

## TOOLS REQUIRED

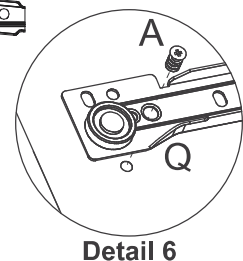
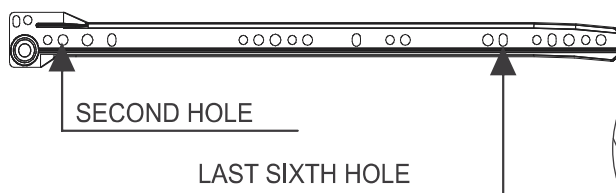
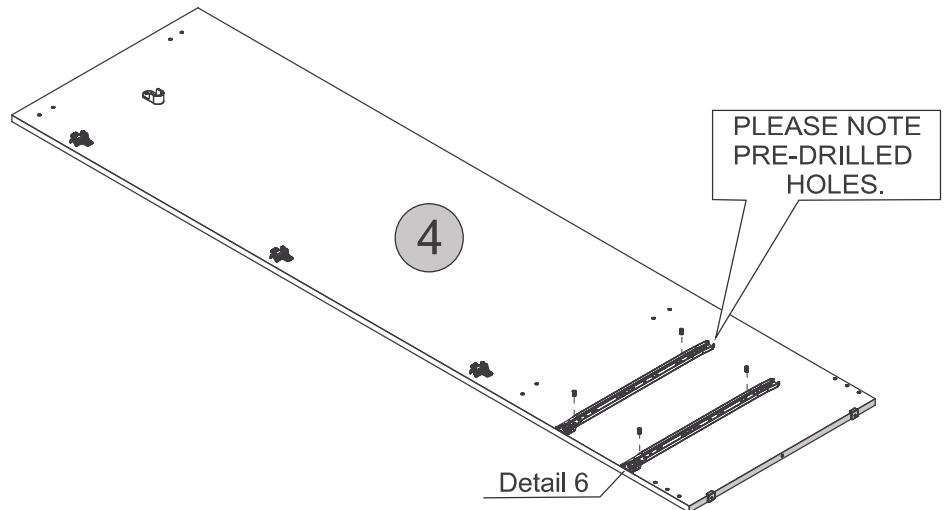
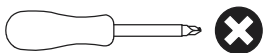





# STEP 3

## PARTS REQUIRED

2 - DIVISION PANEL x1

## HARDWARE REQUIRED

C  08  
Ø4,0 x 14mm

G  02  
Ø6,0 x 30mm

M  01

P  03

V  01

## TOOLS REQUIRED

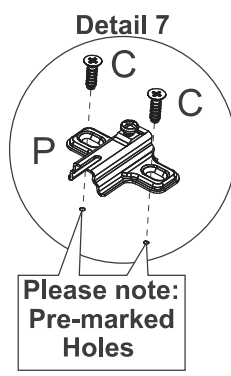
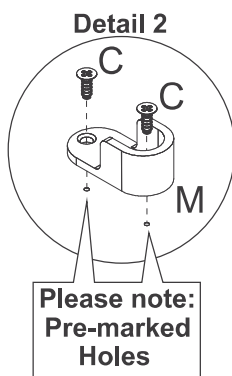
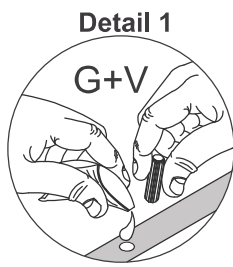
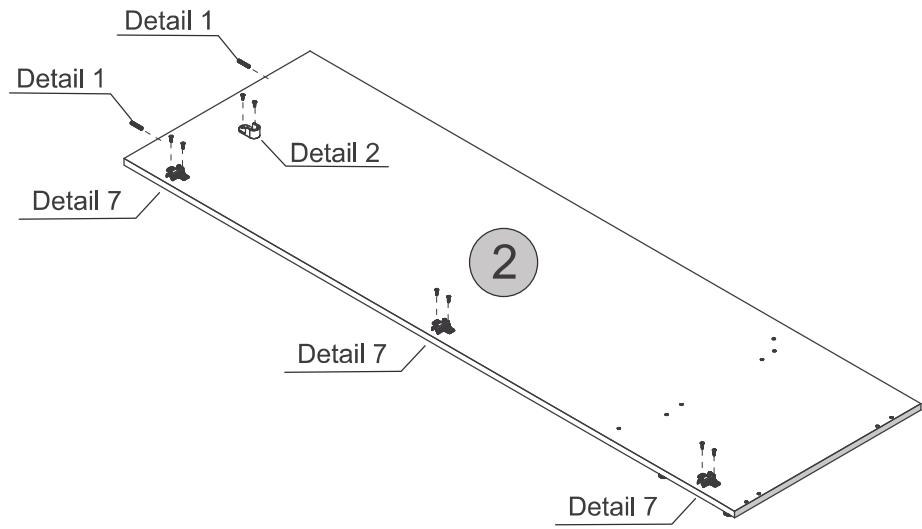
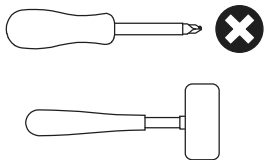

# STEP 4

## PARTS REQUIRED

2 - DIVISION PANEL x1

## HARDWARE REQUIRED

C  08  
Ø4,0 x 14mm

M  01

P  03

## TOOLS REQUIRED

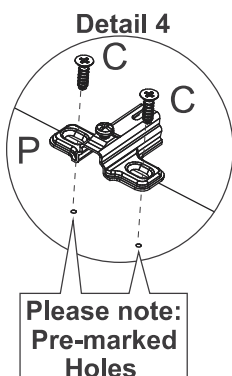
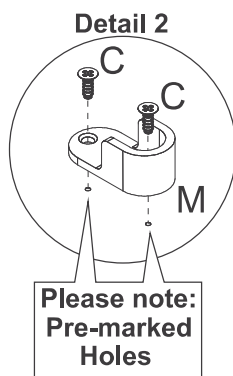
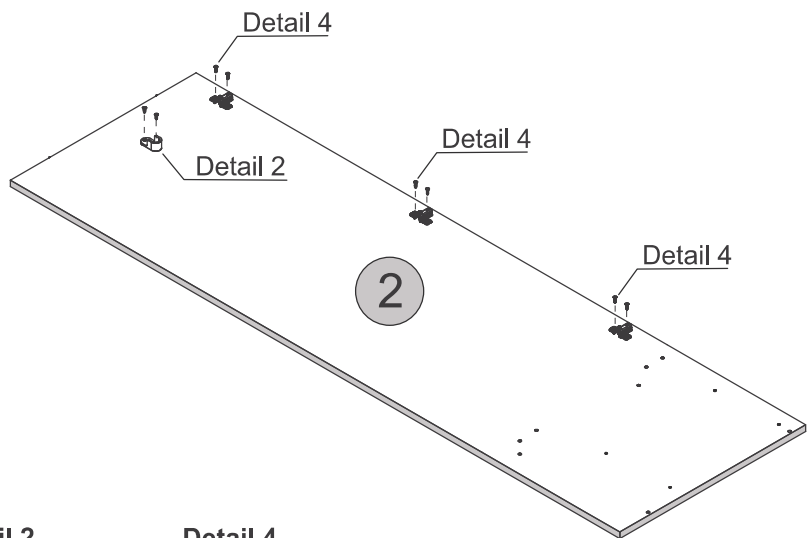
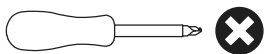

# STEP 5

## PARTS REQUIRED

2 - DIVISION PANEL x1

## HARDWARE REQUIRED

A  04  
Ø6,0 x 10mm

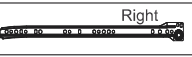
Q  02  
Right

## TOOLS REQUIRED

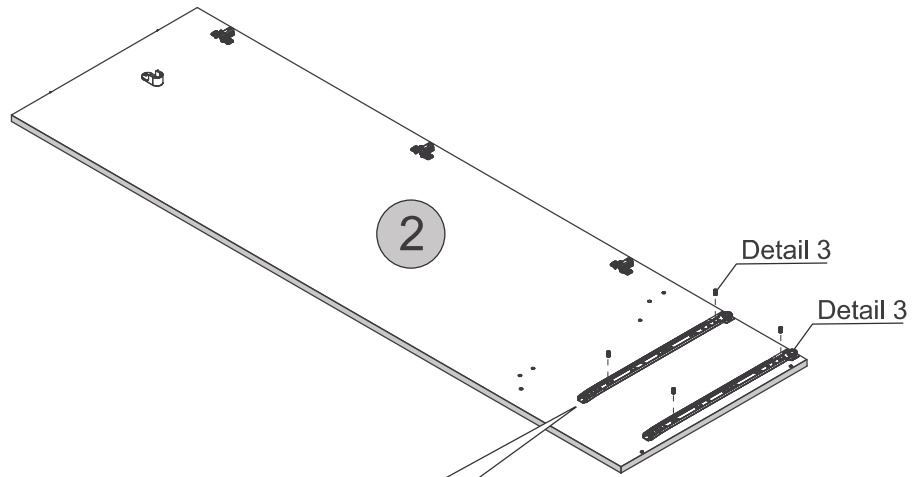
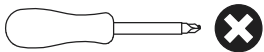

PLEASE NOTE  
PRE-DRILLED  
HOLES.

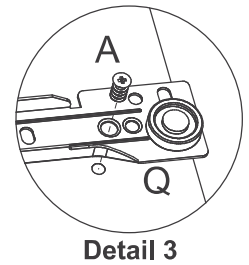
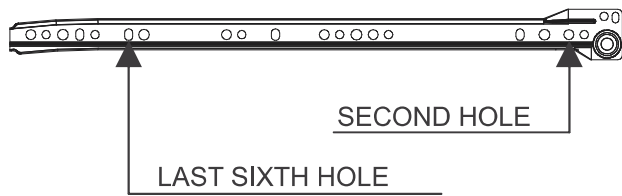



# STEP 6

## PARTS REQUIRED

6 - RIGHT SIDE PANEL x1

## HARDWARE REQUIRED

C  08  
Ø4,0 x 14mm

H  02

L  02

M  01

P  03

## TOOLS REQUIRED

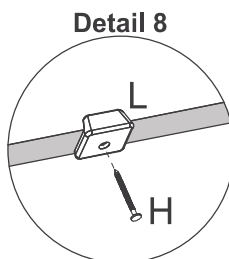
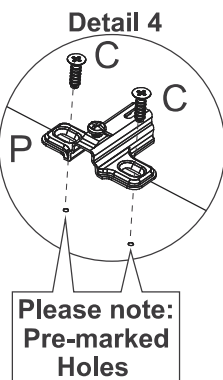
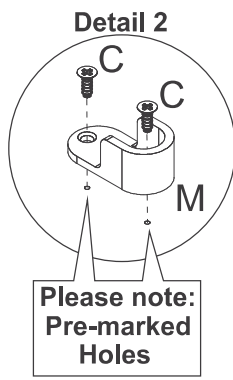
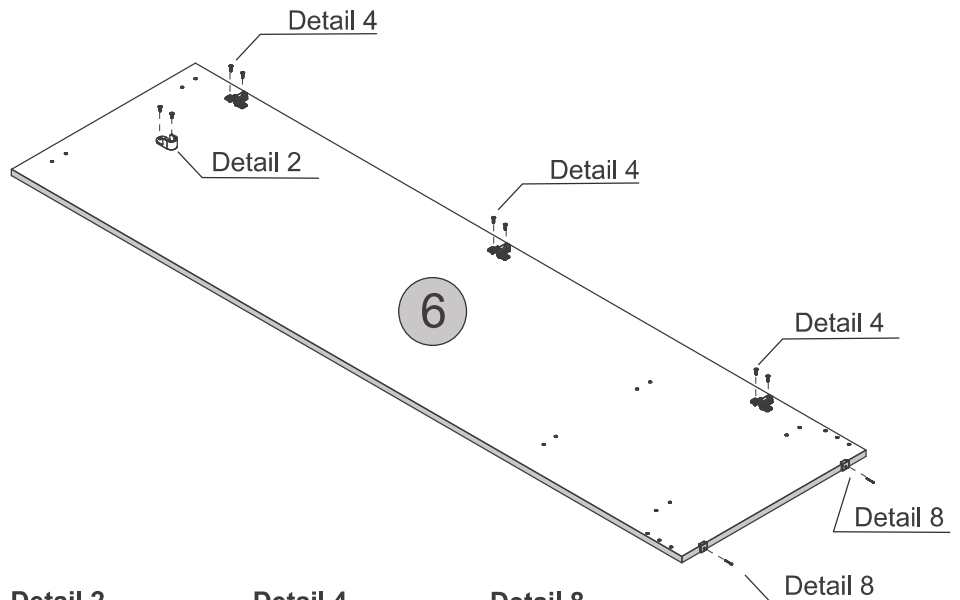
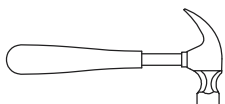
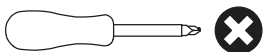

# STEP 7

## PARTS REQUIRED

7 - FRONT BASEBOARD x1

8 - BACK BASEBOARD x1

## HARDWARE REQUIRED

H  02

L  02

G  Ø6,0 x 30mm 08

V  01

## TOOLS REQUIRED

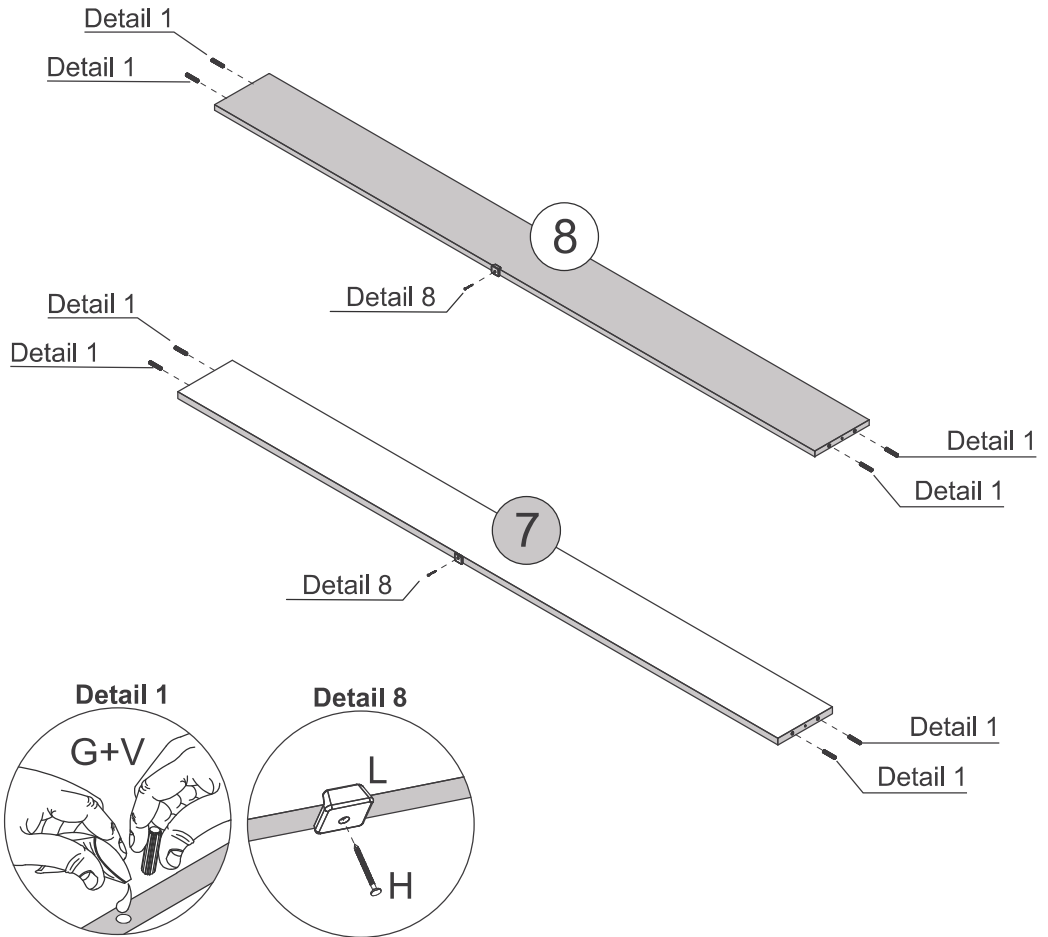
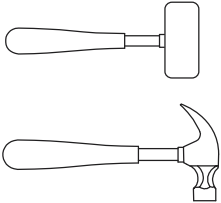

# STEP 8

## PARTS REQUIRED

1 - BASE PANEL x2

5 - SHELF x1

## HARDWARE REQUIRED

G  Ø6,0 x 30mm 12

V  01

Z  Ø4,0 x 12mm 04

A1  02

## TOOLS REQUIRED

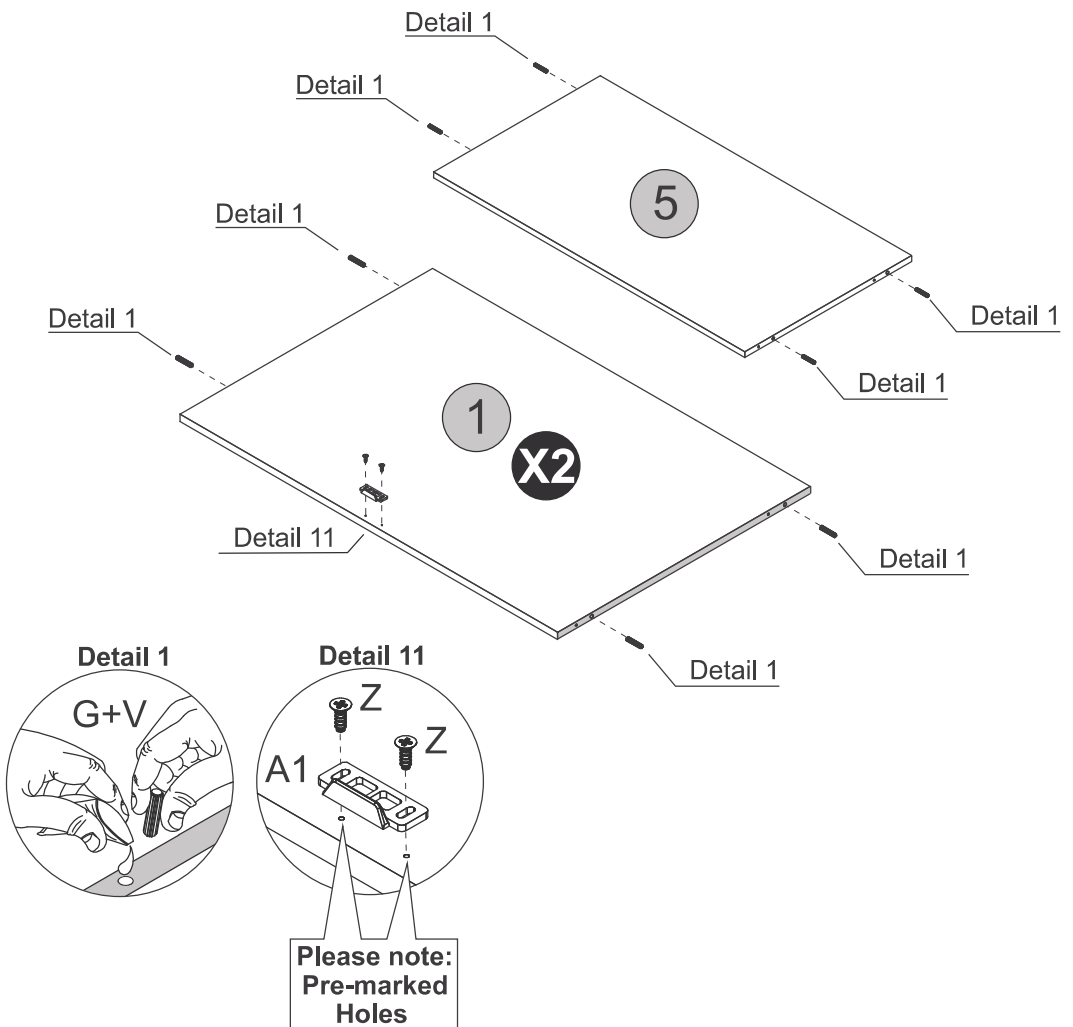
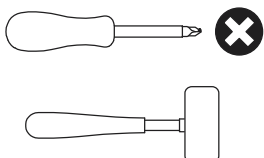



# STEP 11

**PARTS REQUIRED**

4 - LEFT SIDE PANEL x1

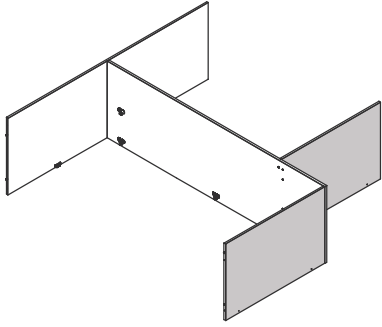

**HARDWARE REQUIRED**

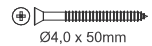
F  04  
Ø4,0 x 50mm

V  01  
Glue

**TOOLS REQUIRED**

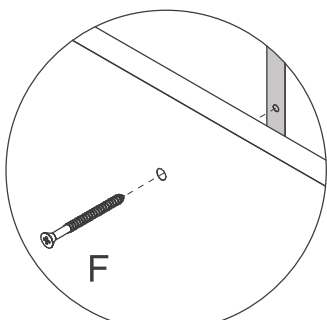
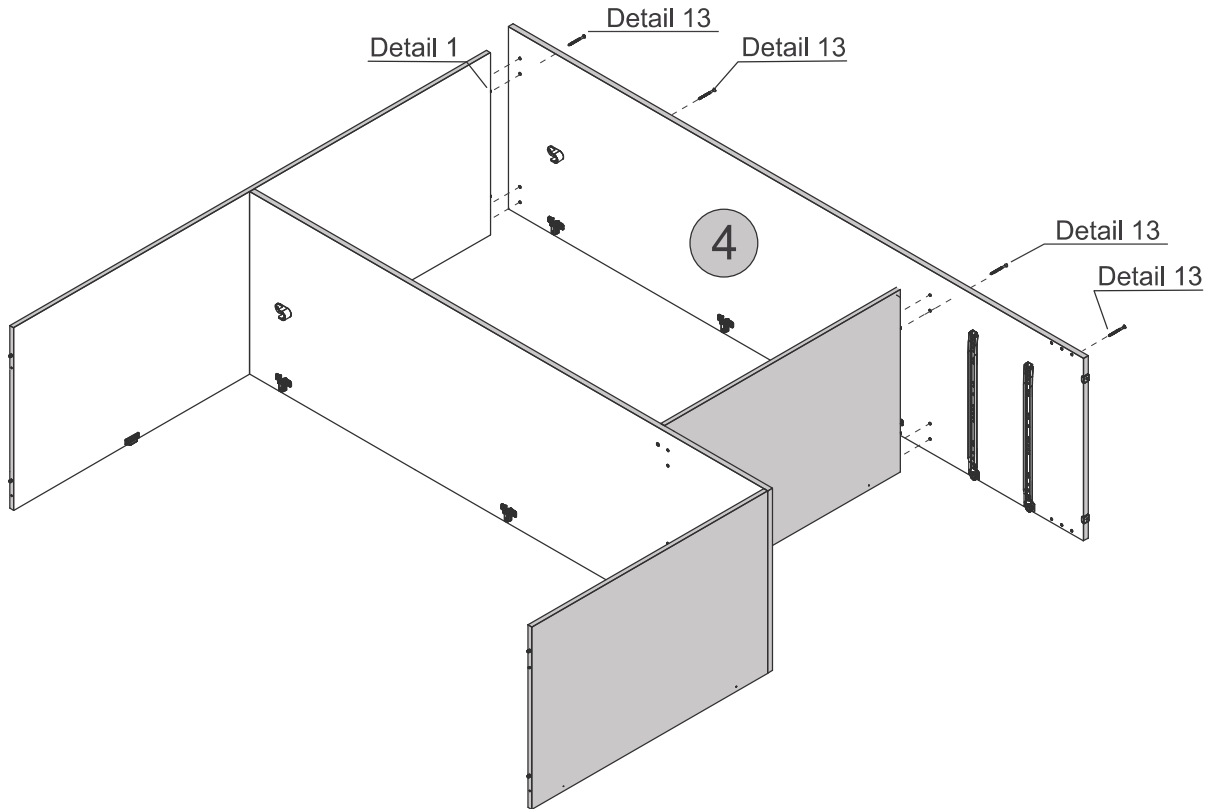
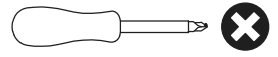

Detail 13

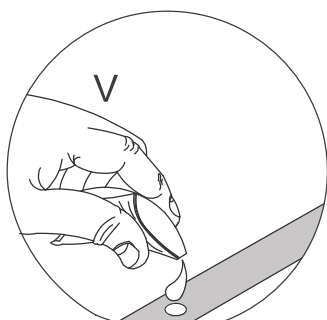



Detail 1

# STEP 12

## PARTS REQUIRED

5 - SHELF	x1
6 - RIGHT SIDE PANEL	x1
7 - FRONT BASEBOARD	x1
8 - BACK BASEBOARD	x1

## HARDWARE REQUIRED

F	 Ø4,0 x 50mm	12
V	 Glue	01

## TOOLS REQUIRED

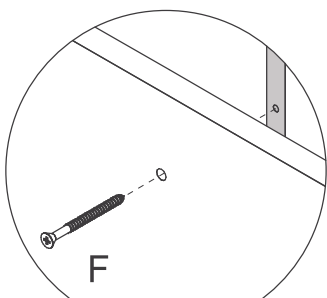
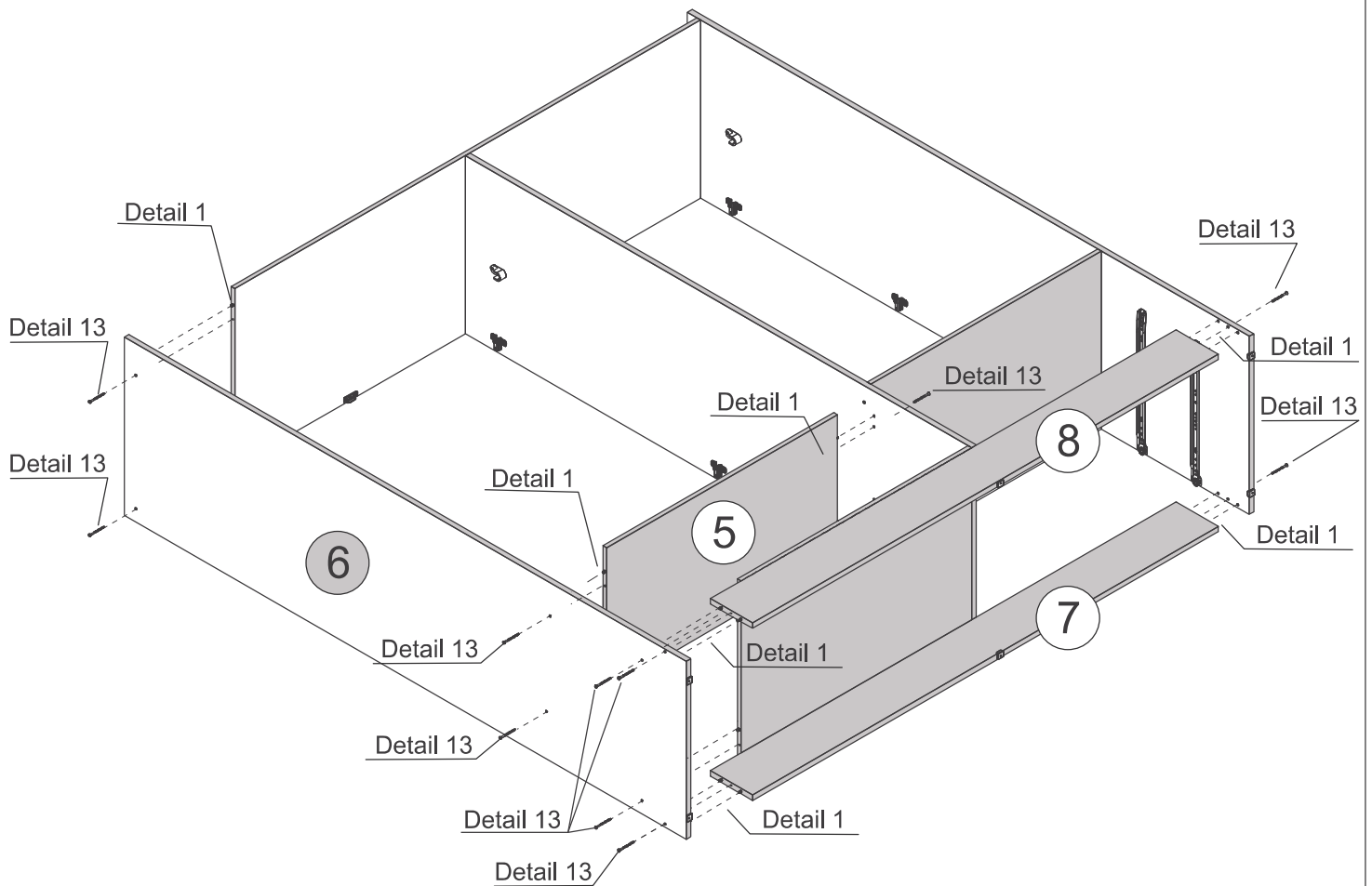
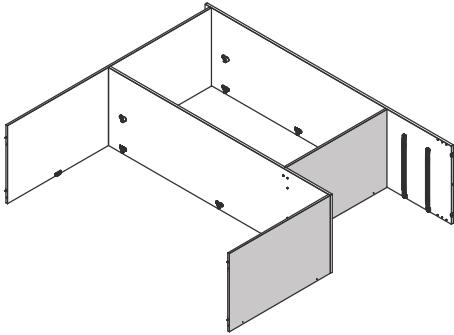
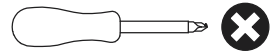

Detail 13

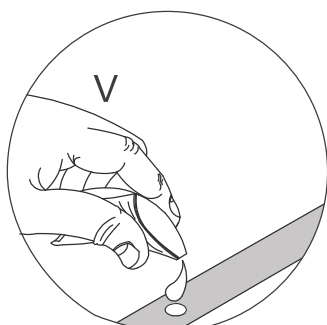

Detail 1





# STEP 13

**PARTS REQUIRED**

9 - BACK PANEL x4

**HARDWARE REQUIRED**

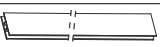
- B  12  
Ø4,0 x 14mm
- H  12  
10 x 10
- R  02

**TOOLS REQUIRED**

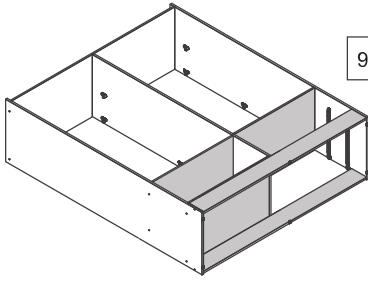
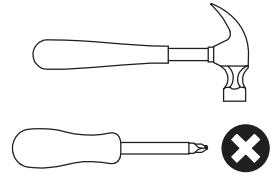

**IMPORTANT PLEASE FOLLOW !**

Please make sure Part 9 is lined up correctly at the top before placing fitting H into the panel as this can affect the alignment of the doors once assembled.

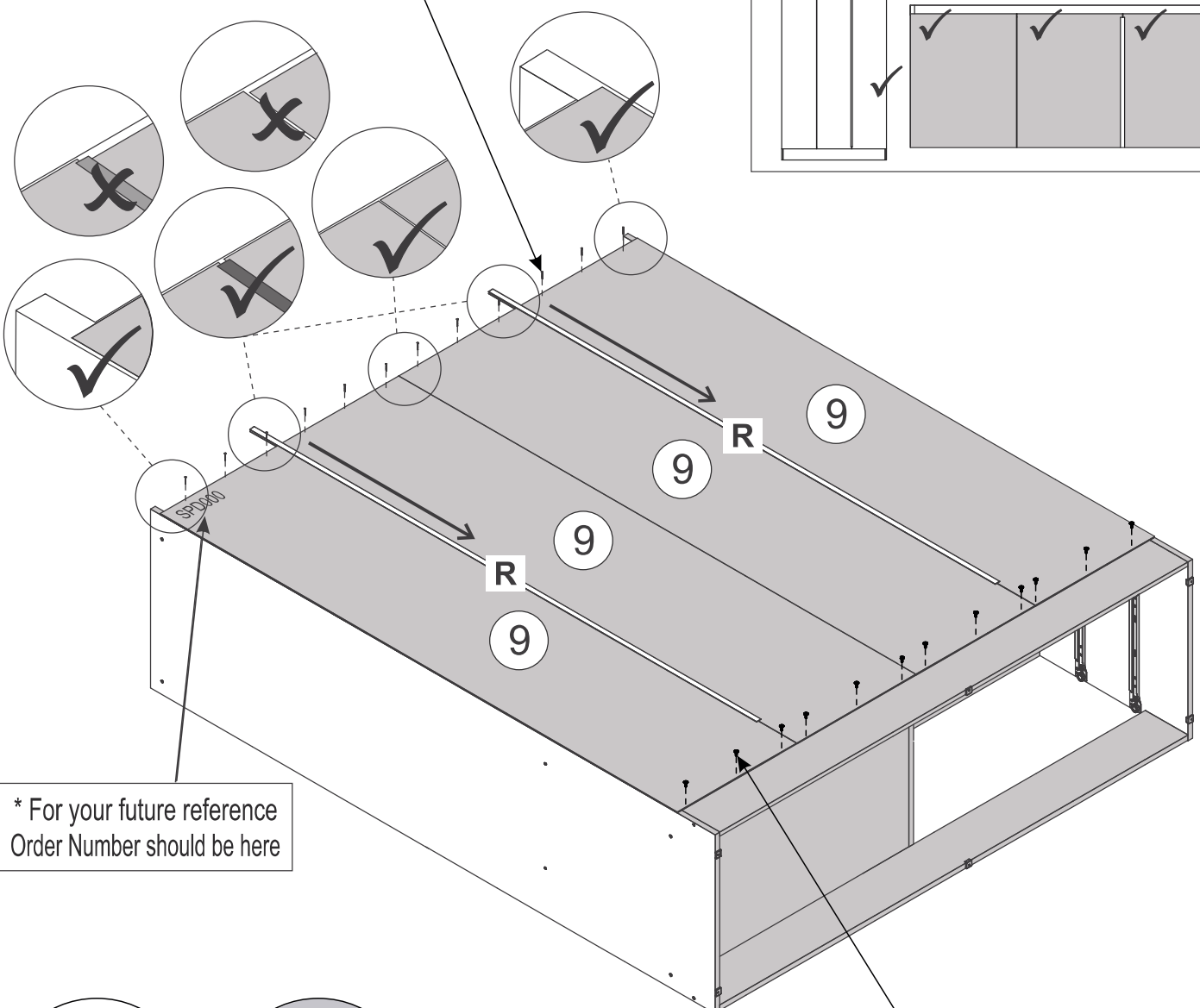
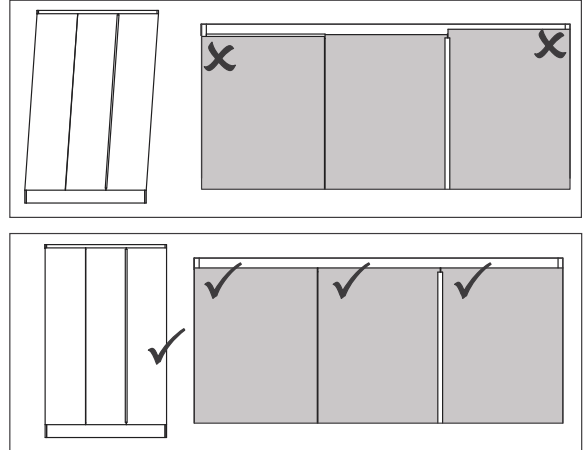

\* For your future reference Order Number should be here

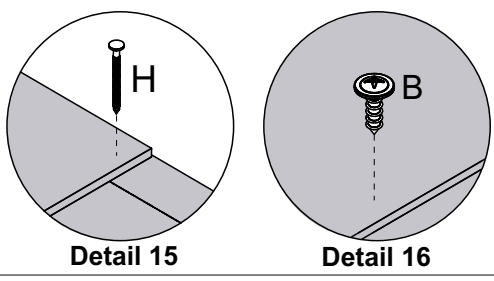

**IMPORTANT PLEASE FOLLOW !**

Please make sure Part 9 isn't Overhanging at the sides before you screw fitting B into the plinth

# STEP 14

**PARTS REQUIRED**

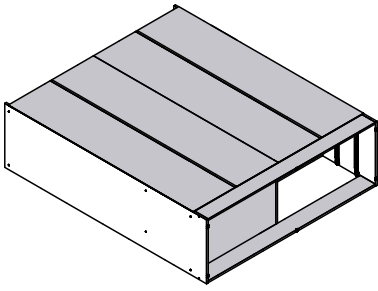

**HARDWARE REQUIRED**

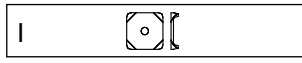
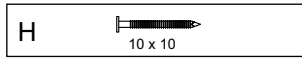

**TOOLS REQUIRED**

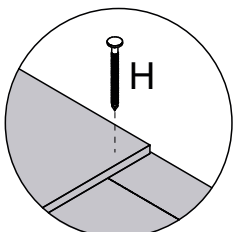
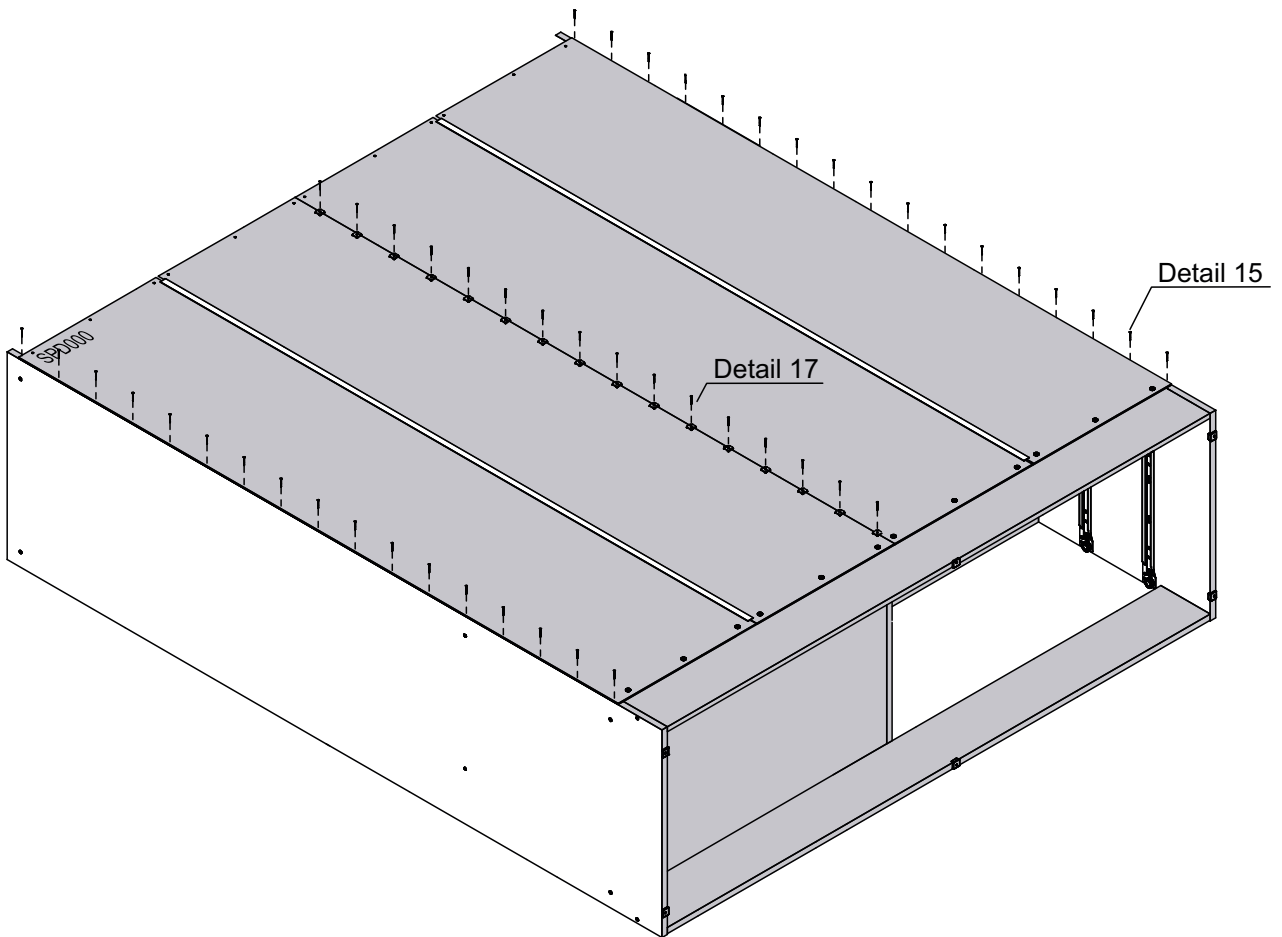
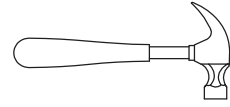

**Detail 15**

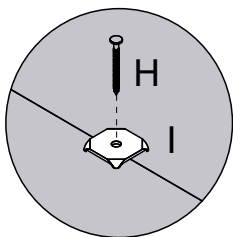

**Detail 17**

# STEP 15

## PARTS REQUIRED

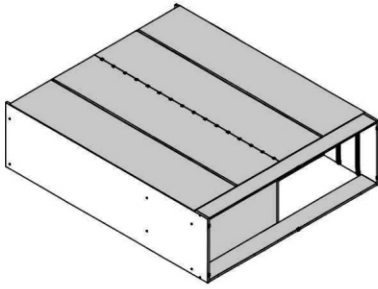

## HARDWARE REQUIRED

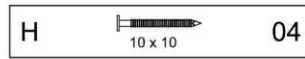

## TOOLS REQUIRED

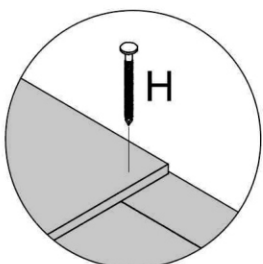
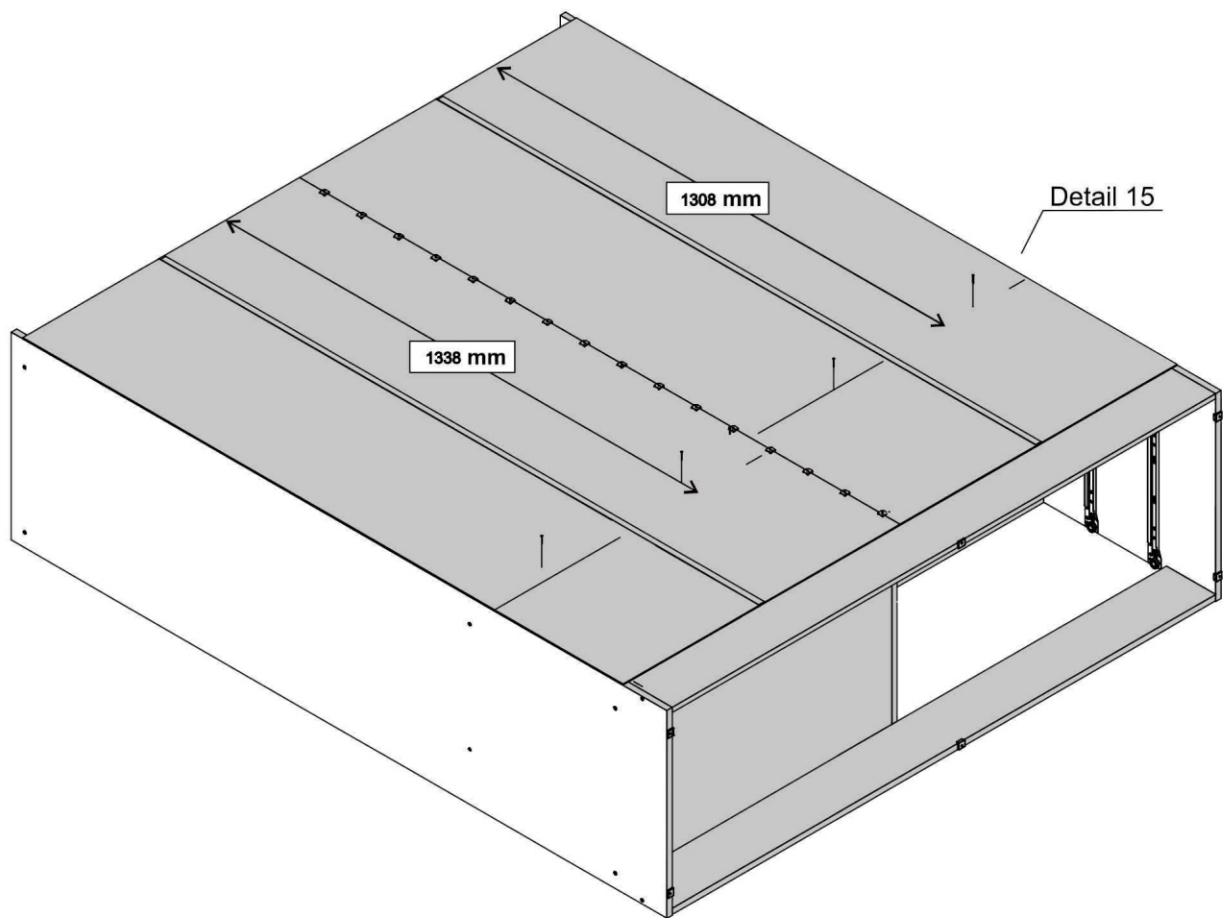
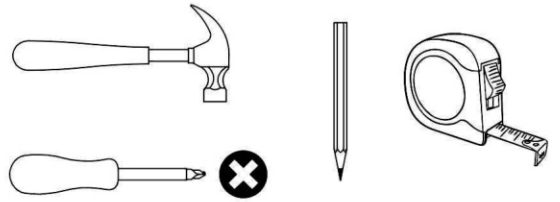

Detail 15

# STEP 16

**PARTS REQUIRED**

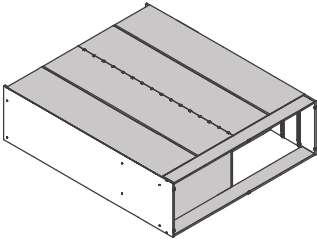

**HARDWARE REQUIRED**

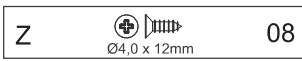
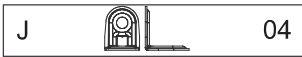

**TOOLS REQUIRED**

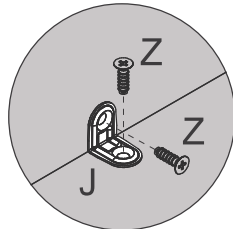
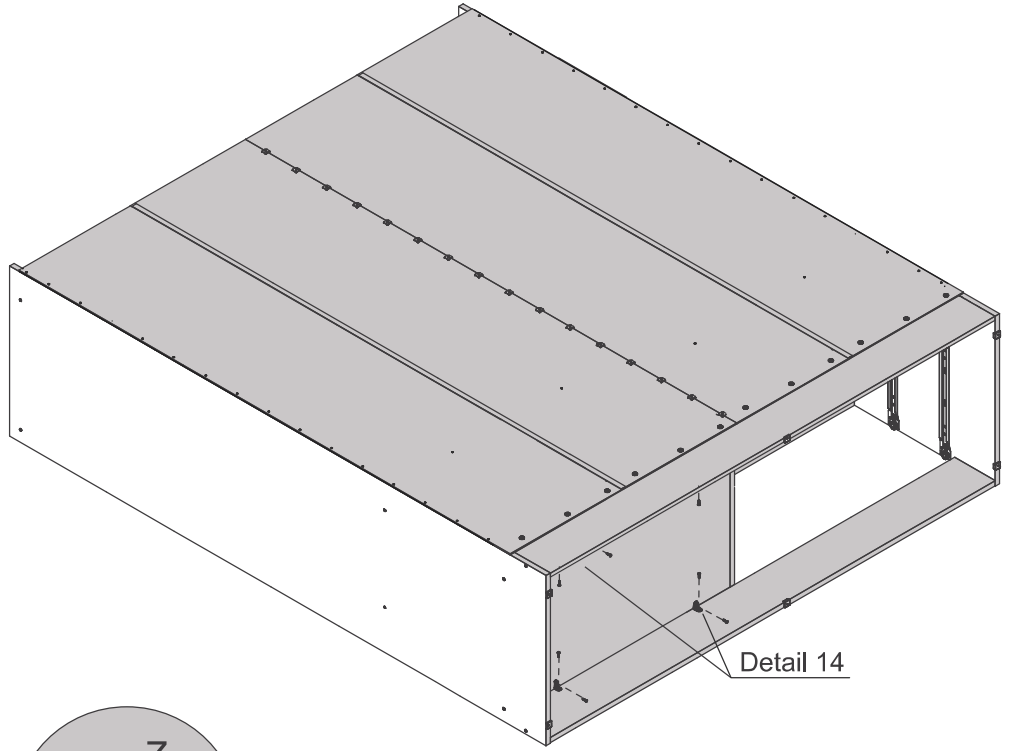
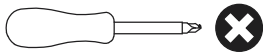

Detail 14

# STEP 17

**PARTS REQUIRED**

10 - FRAME	x1
------------	----

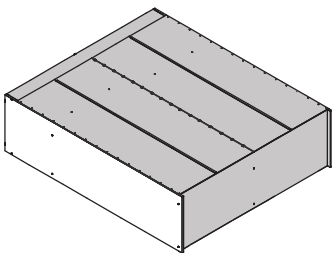

**HARDWARE REQUIRED**

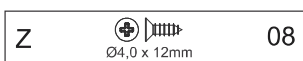

**TOOLS REQUIRED**

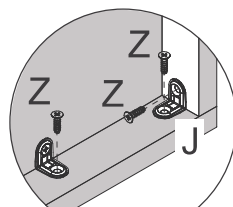
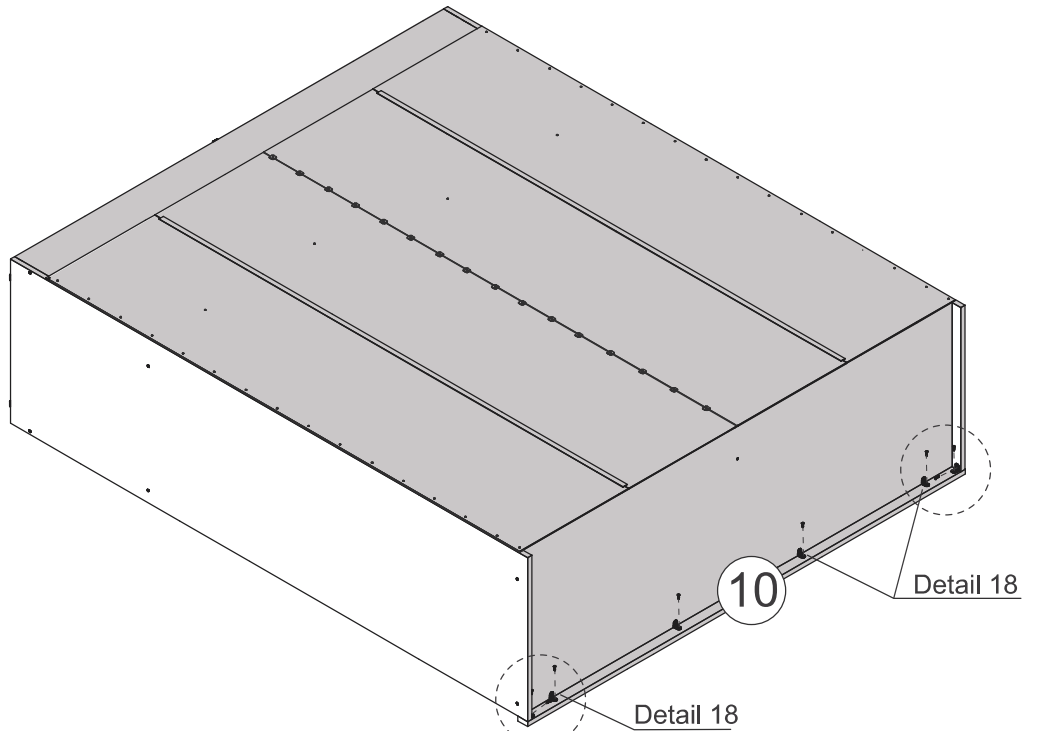
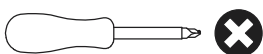

Detail 18

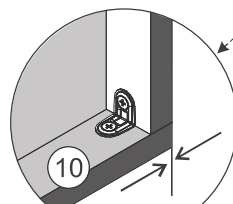

Align corners

# STEP 18

PARTS REQUIRED

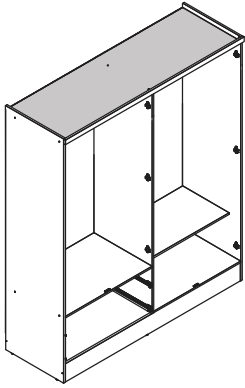

HARDWARE REQUIRED

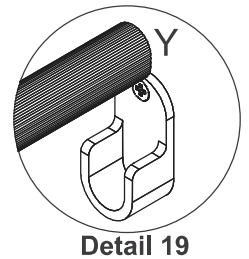
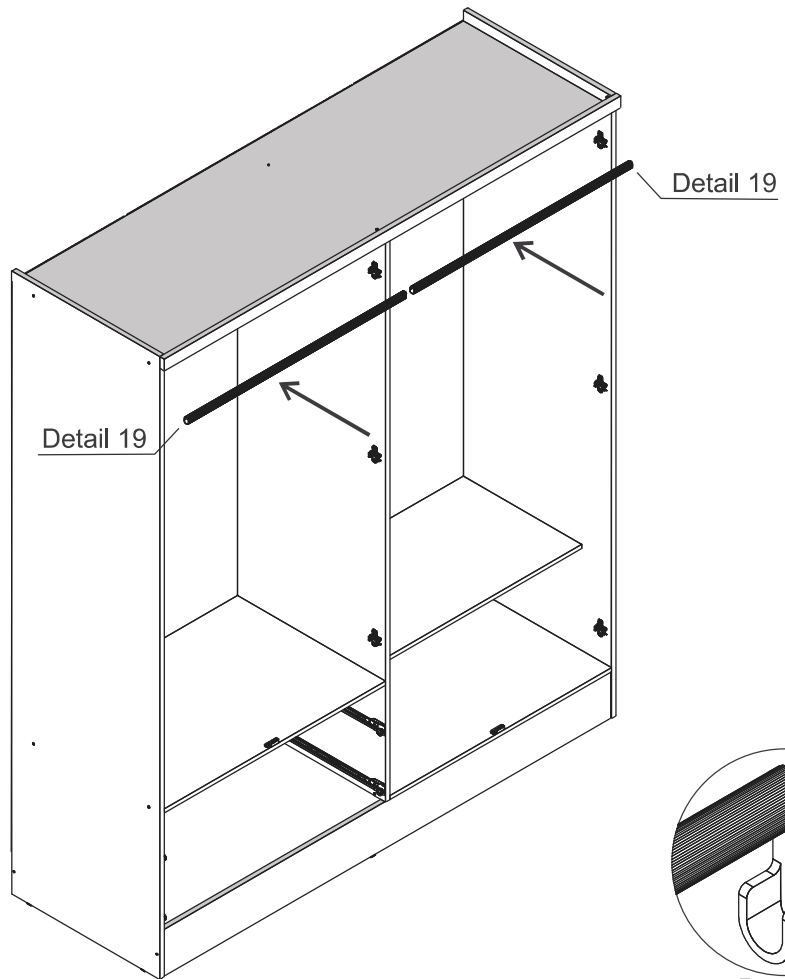
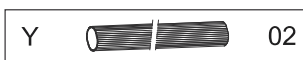

# STEP 19

PARTS REQUIRED

15 - DRAWER SIDE	x4
------------------	----

16 - DRAWER BACK PANEL	x2
------------------------	----

19 - DRAWER BOTTOM SUPPORT BAR	x2
--------------------------------	----

HARDWARE REQUIRED

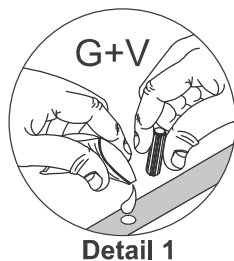
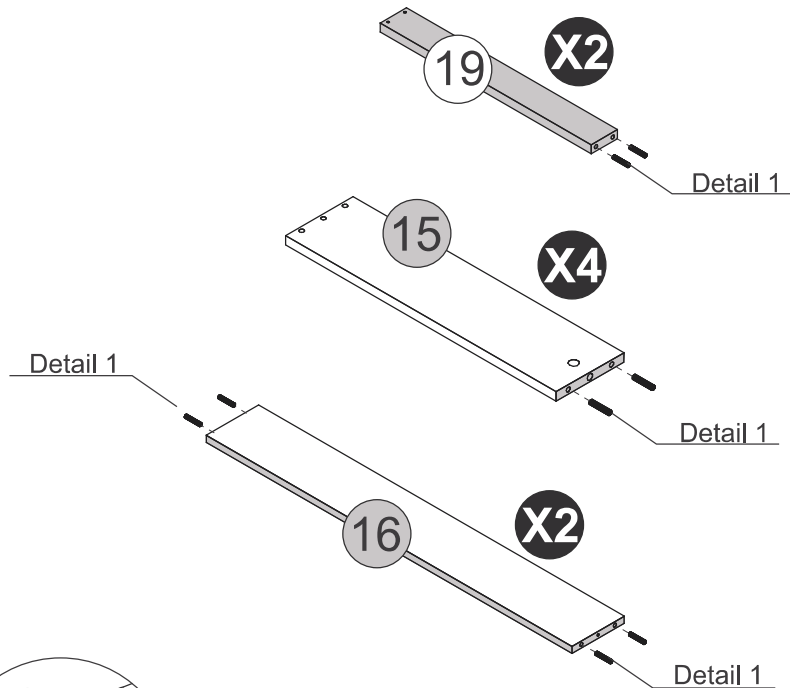
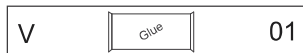
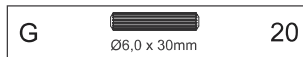

# STEP 20

## PARTS REQUIRED

17 - DRAWER FRONT x2

## HARDWARE REQUIRED

X  04

## TOOLS REQUIRED

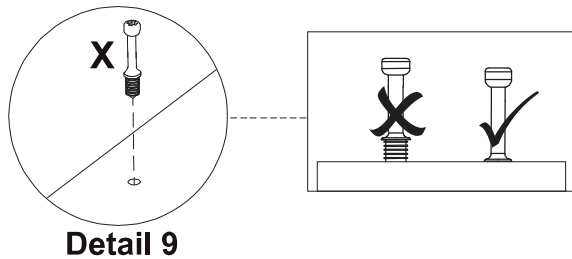
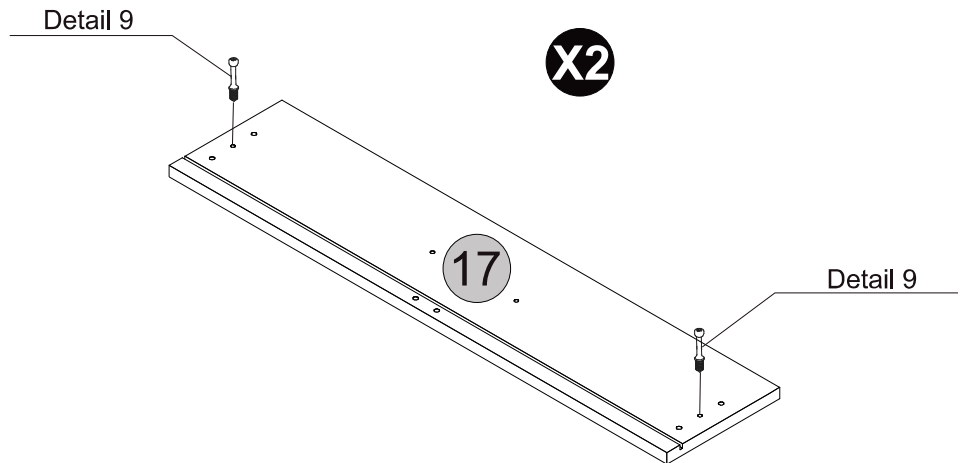
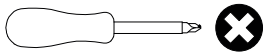

# STEP 21

## PARTS REQUIRED

15 - DRAWER SIDE x4

16 - DRAWER BACK PANEL x2

## HARDWARE REQUIRED

F  Ø4,0 x 50mm 04

## TOOLS REQUIRED

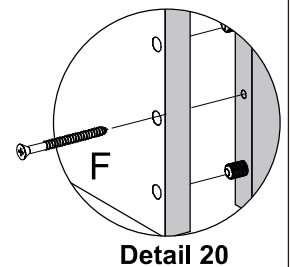
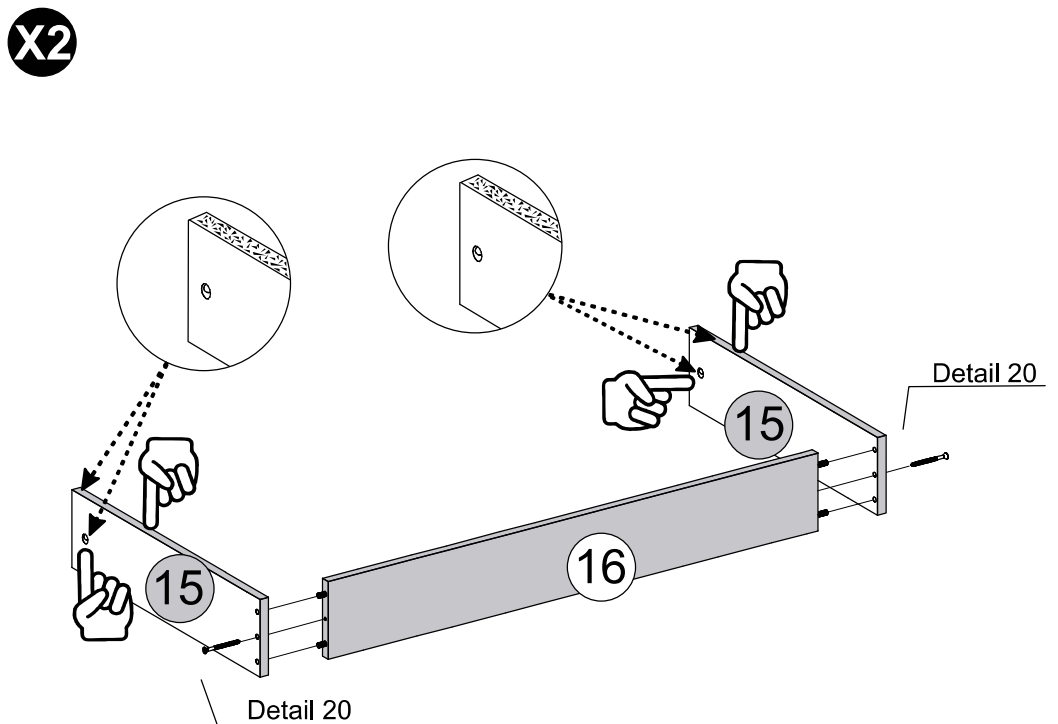
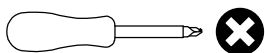



# STEP 22

## PARTS REQUIRED

17 - DRAWER FRONT x2

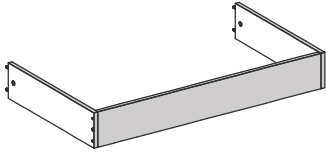

## HARDWARE REQUIRED

B1  04

V  01

W  04

## TOOLS REQUIRED

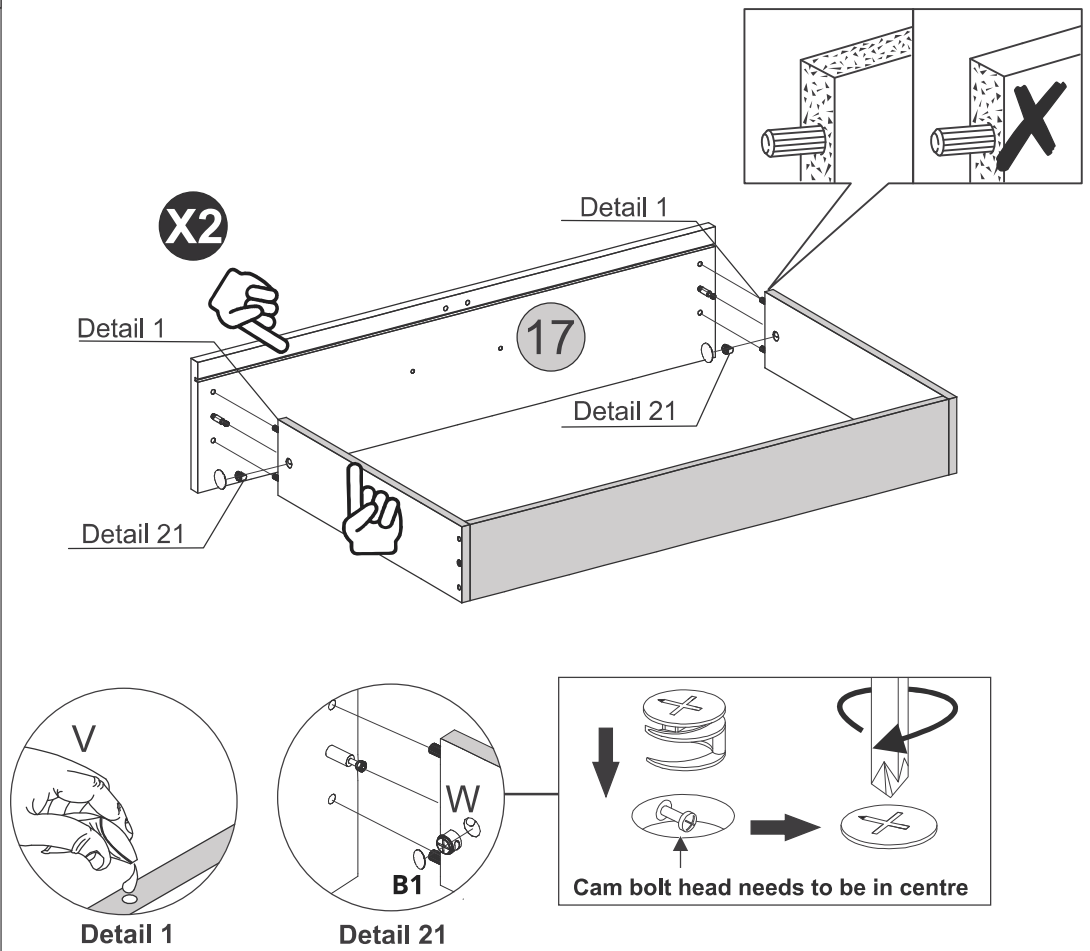
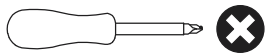

# STEP 23

## PARTS REQUIRED

18 - DRAWER BOTTOM x2

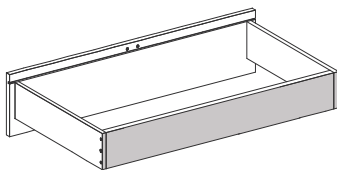

## HARDWARE REQUIRED

H  10 x 10 08

## TOOLS REQUIRED

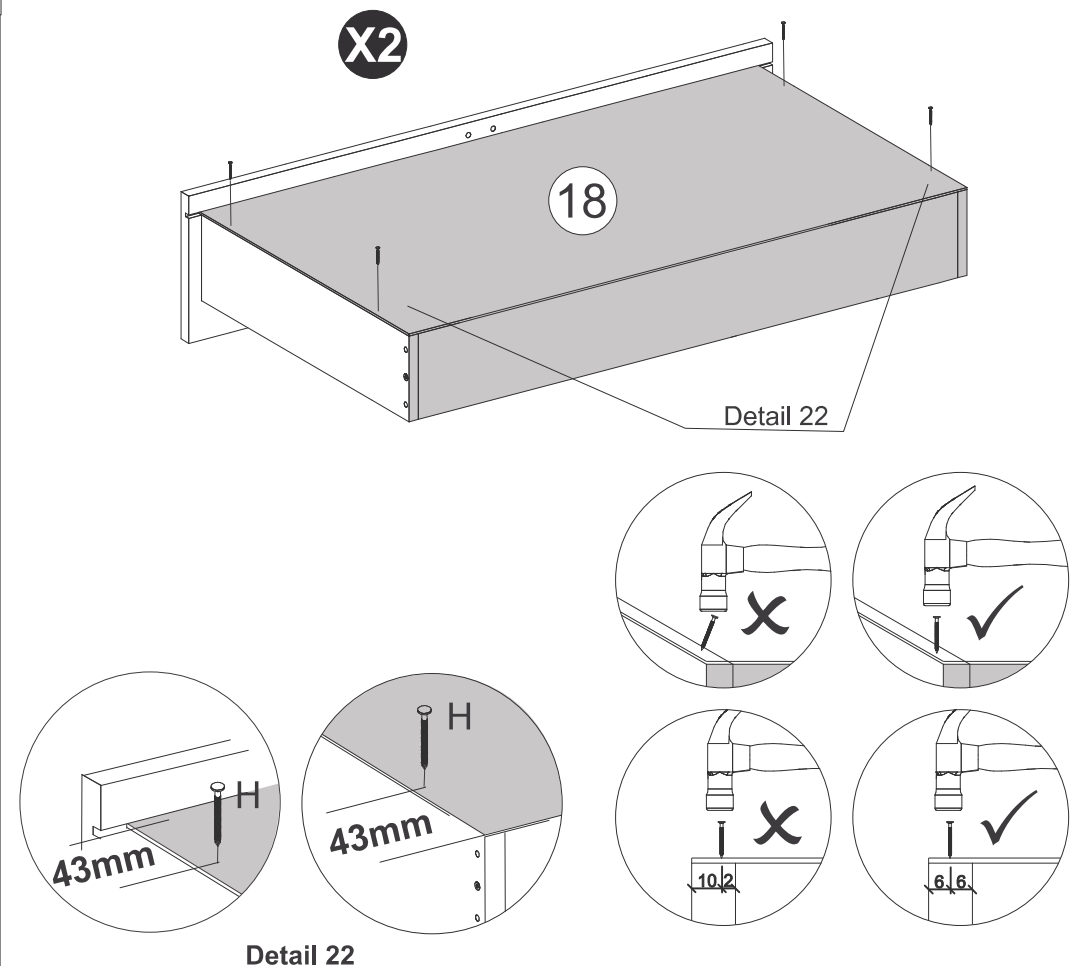
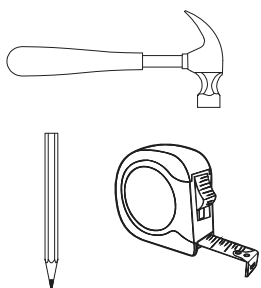

# STEP 24

## PARTS REQUIRED

19 - DRAWER BOTTOM SUPPORT BAR x2

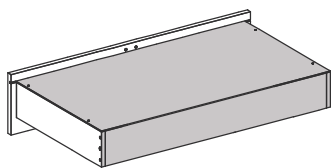

## HARDWARE REQUIRED

H  12  
10 x 10

V  01  
Glue

## TOOLS REQUIRED

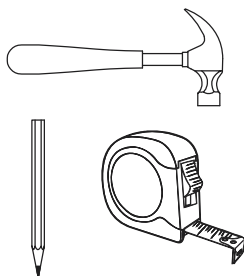

**X2**

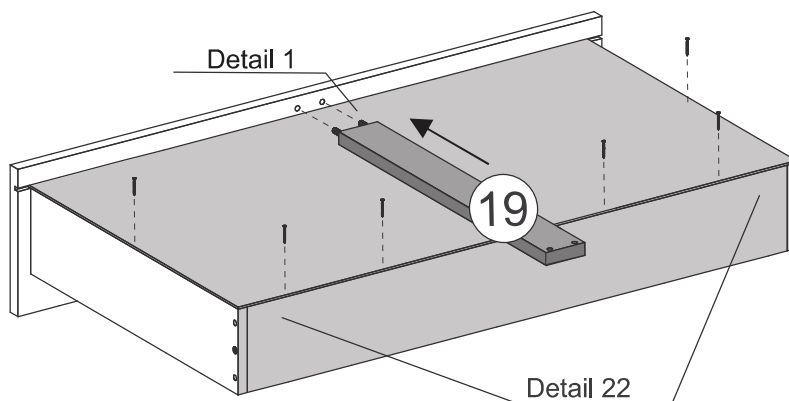

Detail 1

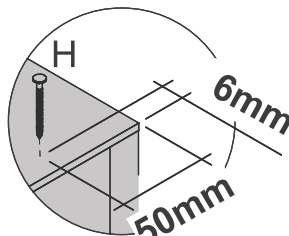

Detail 22

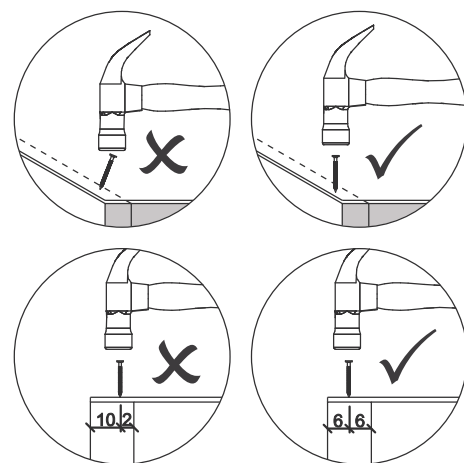

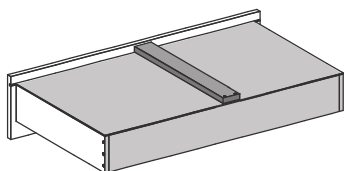

# STEP 25

## PARTS REQUIRED



## HARDWARE REQUIRED

C  08  
Ø4,0 x 14mm

E  04  
Ø3,5 x 40mm

Q  02  
LEFT

Q  02  
RIGHT

## TOOLS REQUIRED

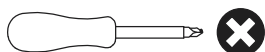

**X2**

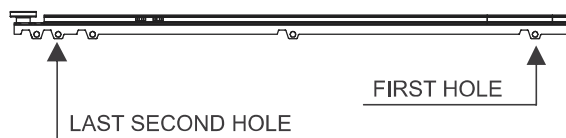
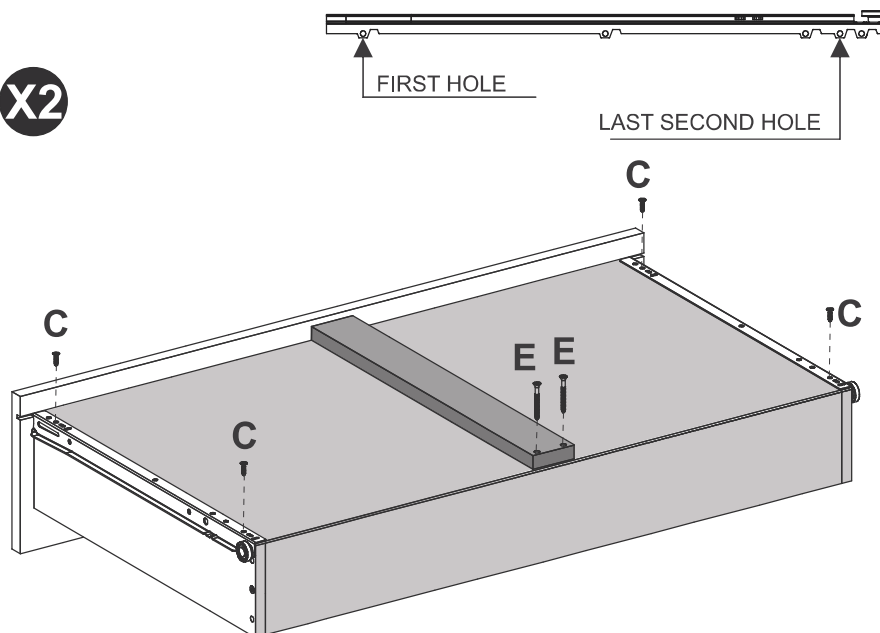



# STEP 26

## PARTS REQUIRED

- 11 - RIGHT LARGE DOOR x1
- 12 - LEFT LARGE DOOR x1
- 13 - RIGHT SMALL DOOR x1
- 14 - LEFT SMALL DOOR x1

## HARDWARE REQUIRED

- C  24  
Ø4,0 x 14mm
- O  12

## TOOLS REQUIRED

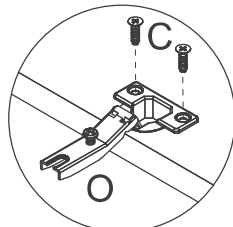
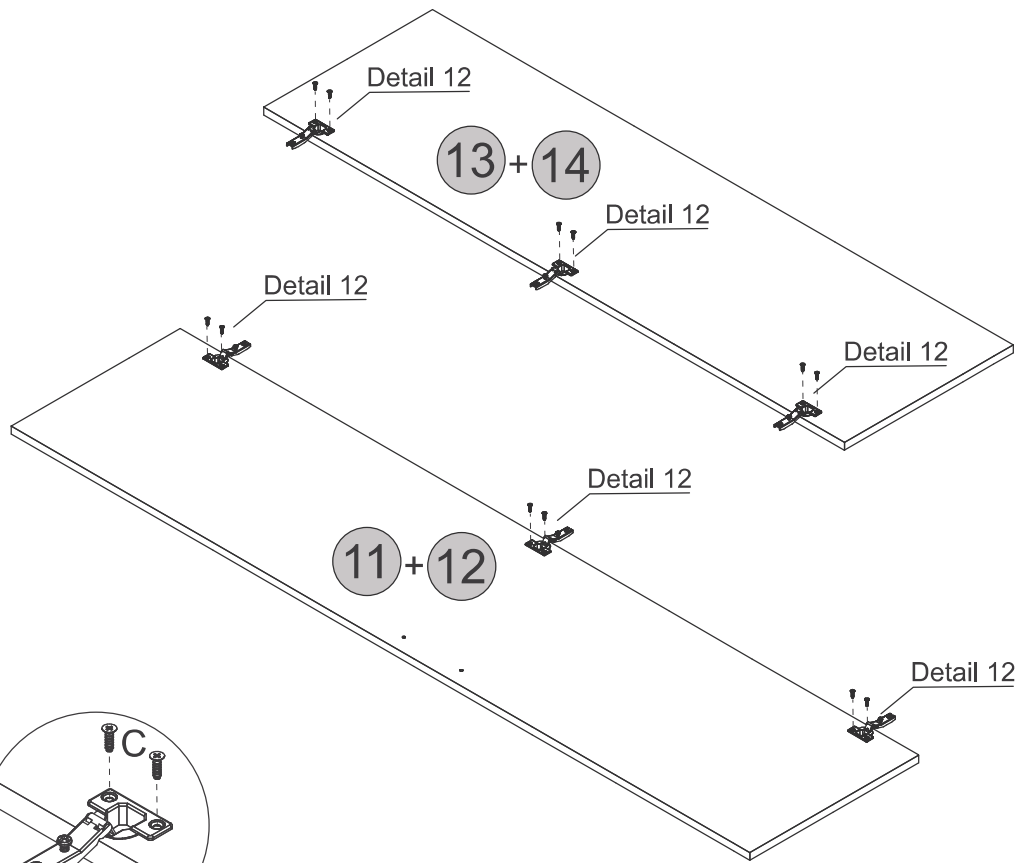
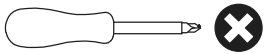

Detail 12

# STEP 27

## PARTS REQUIRED

- 11 - RIGHT LARGE DOOR x1
- 12 - LEFT LARGE DOOR x1
- 13 - RIGHT SMALL DOOR x1
- 14 - LEFT SMALL DOOR x1

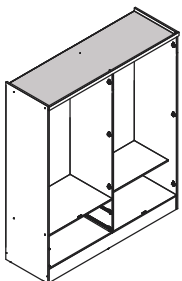

## HARDWARE REQUIRED

- U  26

## TOOLS REQUIRED

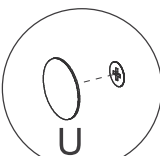
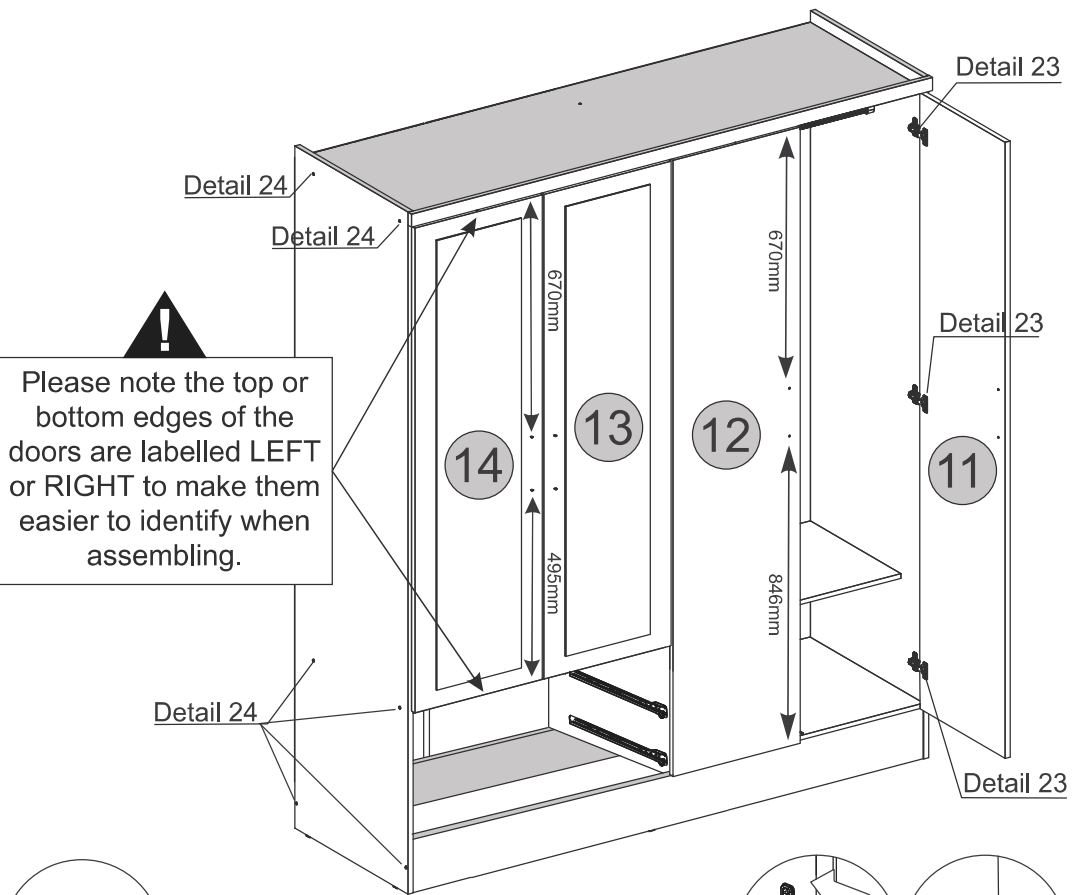

Detail 24

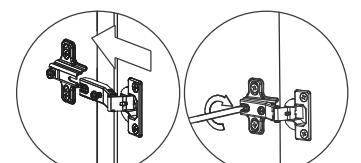

Detail 23

# STEP 28

## PARTS REQUIRED

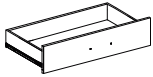
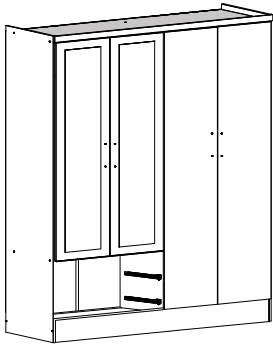

## HARDWARE REQUIRED

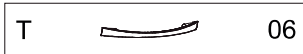
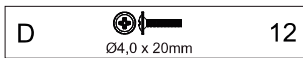

## TOOLS REQUIRED

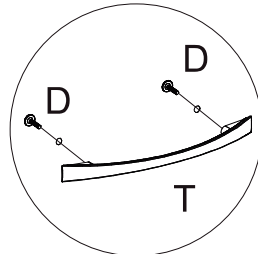
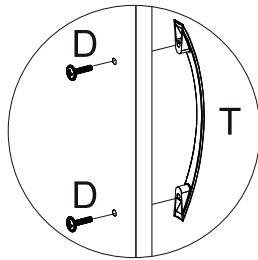
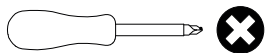

Detail 25

See the last page

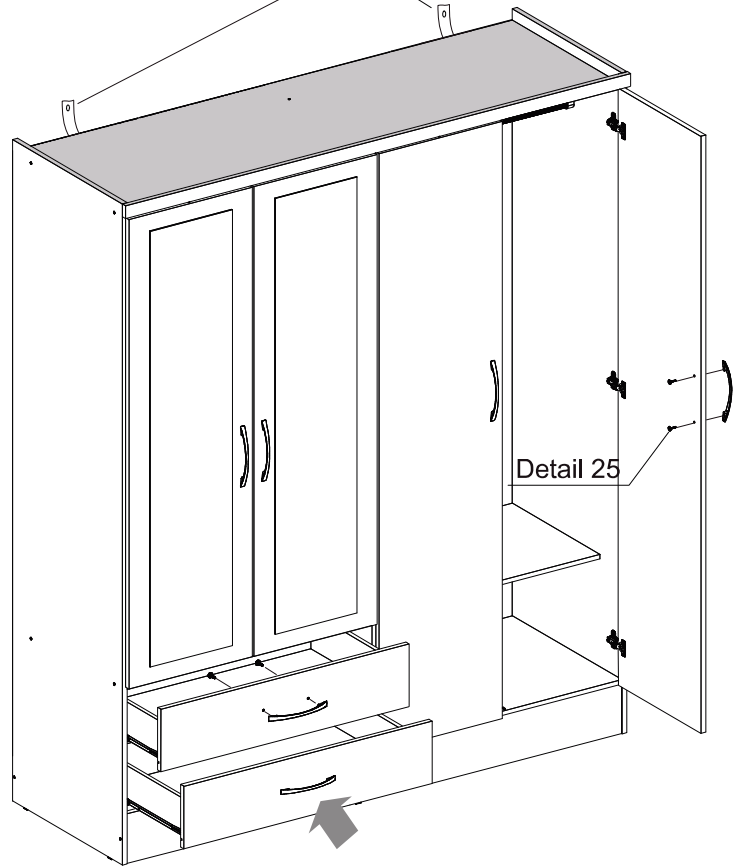

# STEP 29

## PARTS REQUIRED

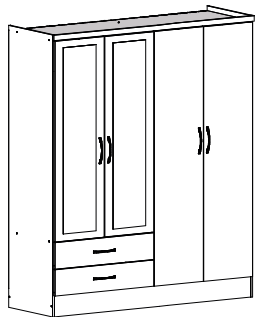

## HARDWARE REQUIRED

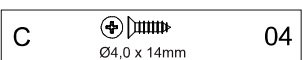

## TOOLS REQUIRED

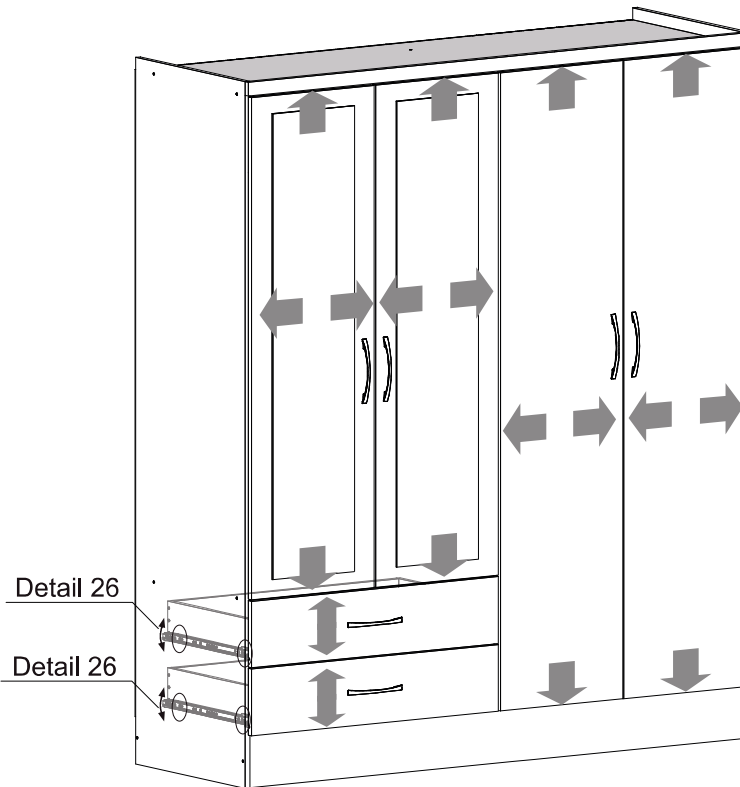
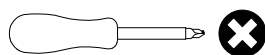

Drawer Adjustment

Drawer Lock

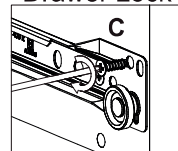
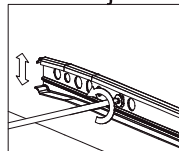

Detail 26

Height Adjustment

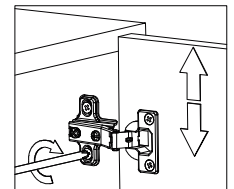

Internal Adjustment

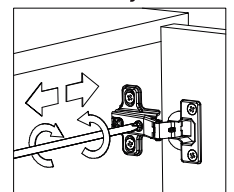

Depth Adjustment

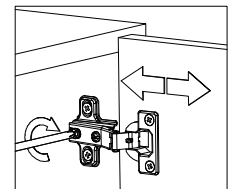
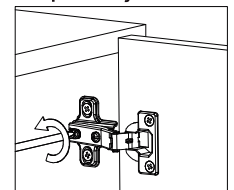

## WARNING

**Serious or fatal injuries can occur from furniture tipping over. To prevent the furniture from tipping over we recommend that it is permanently fixed to the wall.**

Wall fixings are not supplied with this product as different wall materials require different types of fixing devices.

Please make sure you use fixings suitable for the walls in your home.

