

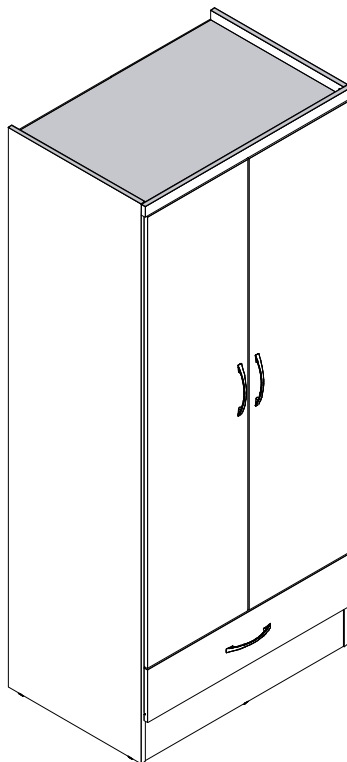

NEVADA 2 DOOR 1 DRAWER WARDROBE ASSEMBLY INSTRUCTIONS



IMPORTANT FOR DOMESTIC USE ONLY PLEASE READ BEFORE YOU CONTINUE FURTHER CARE AND MAINTENANCE

After unpacking this product please keep the original packaging in case it needs to be returned for any reason.

- Please ensure all fittings and parts are present before commencing with assembly.
- Never drag or push products as this could cause damage to the joints making it inferior.
- We strongly recommend that you keep children away from your work area.
- We recommend that you lay a blanket or sheet on the floor to avoid damage to both your floor and the product.
- Assemble this product as close to its final position as possible.
- Do not place this product next to a radiator or in direct sunlight.
- Do not drag or push items across your high gloss furniture as this may cause the surface to scratch
- Wood is a natural product and may expand if subjected to damp and may shrink or crack if subjected to heat. Therefore it is recommended that room temperature is maintained, with no sudden temperature fluctuations.
- Make sure any spillage is wiped off immediately.
- Do not place hot or chilled items directly on to the surface, use a place mat or marking will occur.
- For general cleaning use a soft cotton or micro fibre cloth, and do not use detergents of any kind.
- From time to time it may be necessary to tighten fittings, regular inspections should be carried out.
- Do not place on a wet or damp floor as staining may occur to your floor.

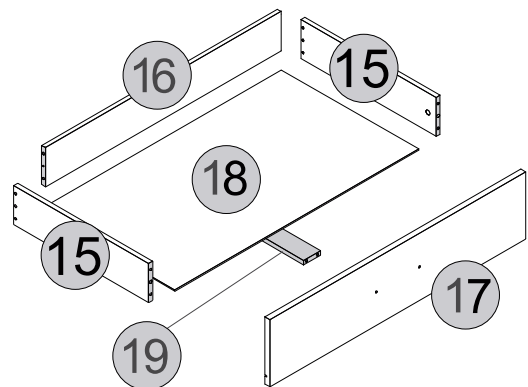
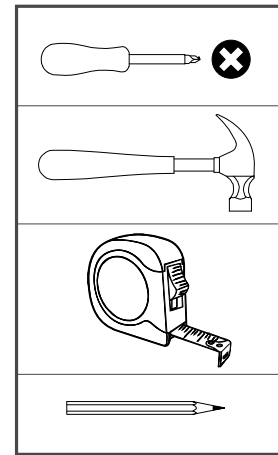
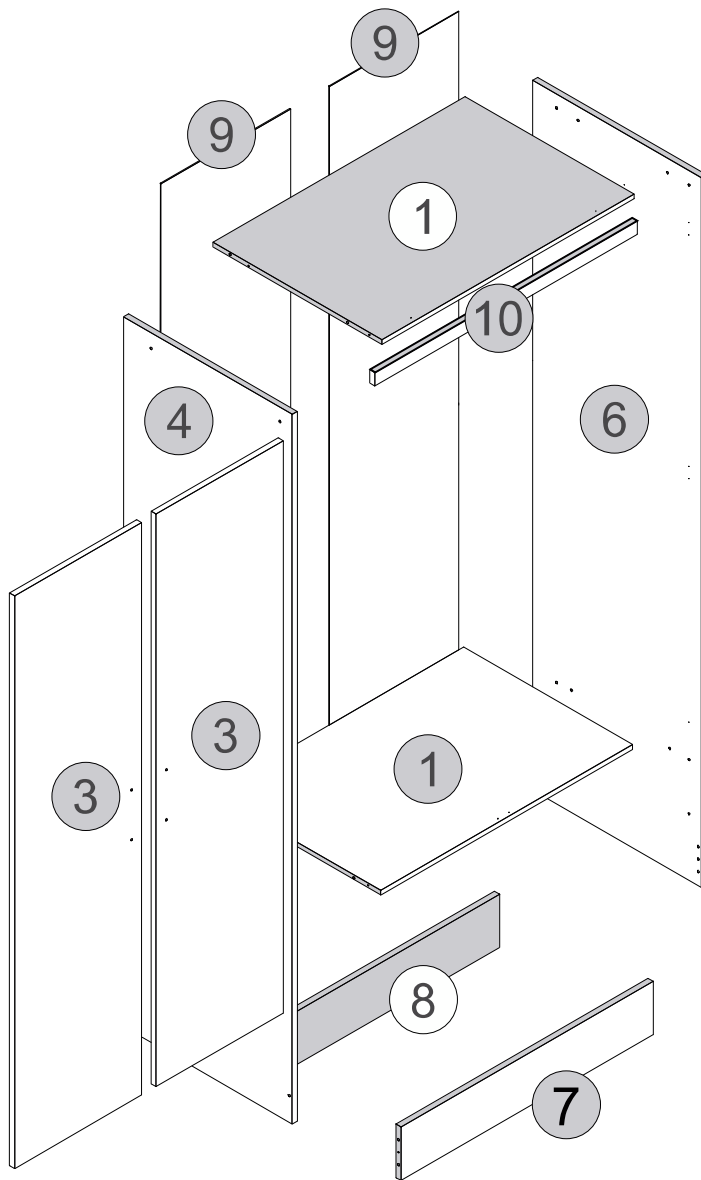











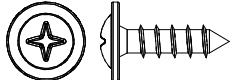
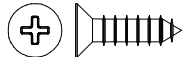
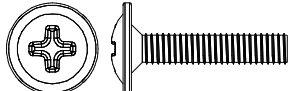
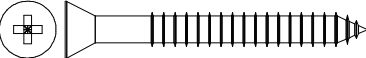
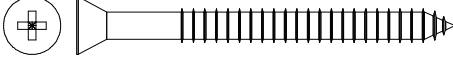

PARTS LIST

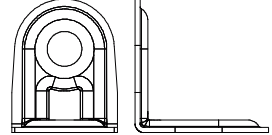
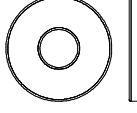
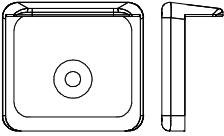
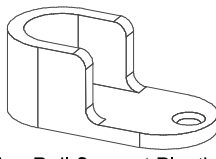
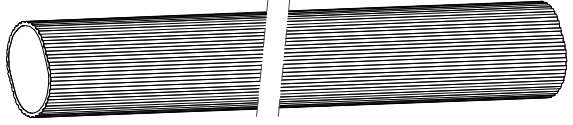
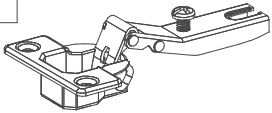
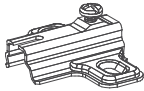
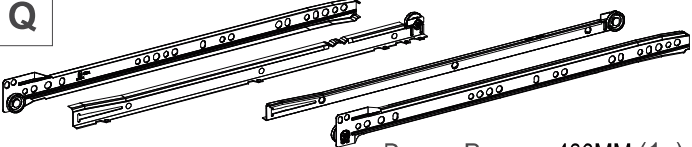
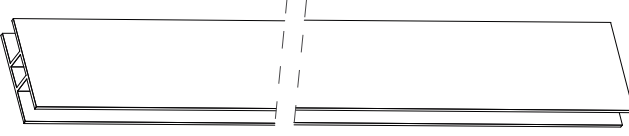
Please Note:
The below parts have all been stamped with the part number to help identify them during assembly.

Part Number	Part Description	Quantity	Carton
01	Base-Top Panel	2	1/2
03	Door	2	2/2
04	Left Side Panel	1	1/2
06	Right Side Panel	1	1/2
07	Front Baseboard	1	2/2
08	Back Baseboard	1	2/2
09	Back Panel	2	1/2
10	Frame	1	2/2
15	Drawer Side	2	1/2
16	Drawer Back Panel	1	2/2
17	Drawer Front	1	2/2
18	Drawer Bottom	1	1/2
19	Drawer Bottom Support Bar	1	2/2

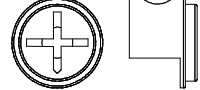
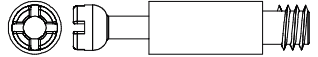
FITTINGS LIST

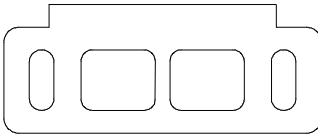
SEC/SW/04/23/HV1

<p>A</p>  <p>Flat Head Screw Ø6,0 x 10mm (4x)</p> <p>1/+</p>	<p>B</p>  <p>Flan Head Screw Ø4,0 x 14mm (6x)</p> <p>1/+</p>	<p>C</p>  <p>Flat Head Screw Ø4,0 x 14mm (34x)</p> <p>2/+</p>	<p>D</p>  <p>Flan Head Screw Ø4,0 x 20mm (6x)</p> <p>1/+</p>
<p>E</p>  <p>Flat Head Screw Ø3,5 x 40mm (2x)</p> <p>1/+</p>	<p>F</p>  <p>Flat Head Screw Ø4,0 x 50mm (14x)</p> <p>2/+</p>	<p>G</p>  <p>2/+ Dowel Ø6,0 x 30mm (26x)</p>	
<p>H</p>  <p>2/+ Nail 10x10 Ringed-1,5x23mm (58x)</p>	<p>I</p>  <p>Flan Head Screw Ø3,5 x 30mm (2x)</p> <p>1/+</p>	<p>J</p>  <p>1/+ 'L' Metallic Support 18x18MM (4x)</p>	<p>K</p>  <p>1/+ Washer Ø16x7(4x)</p>
<p>L</p>  <p>1/+ Plastic Foot L 19x17x8mm Ø2 (6x)</p>	<p>M</p>  <p>Hanging Rail Support Plastic (2x)</p>	<p>N</p>  <p>Hanging Rail 737x30X16X0,60MM (1x)</p>	
<p>O</p>  <p>Hinge 26MM High Lap (6x)</p>	<p>P</p>  <p>Hinge Plate 26MM D5 (6x)</p>	<p>Q</p>  <p>Drawer Runners 400MM (1x)</p>	
<p>R</p>  <p>Back Panel Strip H 1633x19x3,8MM (1x)</p>	<p>S</p>  <p>Strap 200x20x1MM (2x)</p>	<p>T</p>  <p>Handle (3x)</p>	
<p>U</p>  <p>2/+ Hole Plugs 19MM (14x)</p>	<p>V</p>  <p>Glue 10Gr (1x)</p>	<p>W</p>  <p>1/+ Cam Nut Ø12x8,8MM (2x)</p>	<p>X</p>  <p>1/+ Cam Bolt (2x)</p>
<p>Y</p>  <p>Flat Head Screw Ø4,0 x 12mm (12x)</p> <p>2/+</p>	<p>Z</p>  <p>Door Support L42xP27xA28MM (2x)</p>	<p>A1</p>  <p>+/-2 Hole Plugs Líneo 19mm (2x)</p>	

TIPS FOR FITTINGS CAM-LOCKS

WHEN FITTING CAM NUT. ENSURE STARTING POSITION IS CORRECT BEFORE YOU INSERT CONNECTING CAM BOLT TURN CLOCKWISE UNTIL SECURE

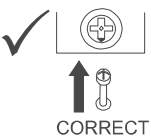

✓

CORRECT

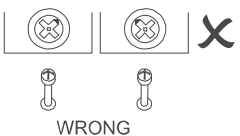

✗

WRONG

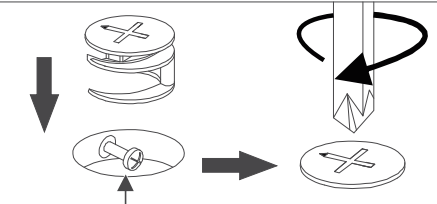

Cam bolt head needs to be in centre

CAMBOLT

Tighten until shoulder in flush with panel. Do not overtighten or undertighten (see example beside)

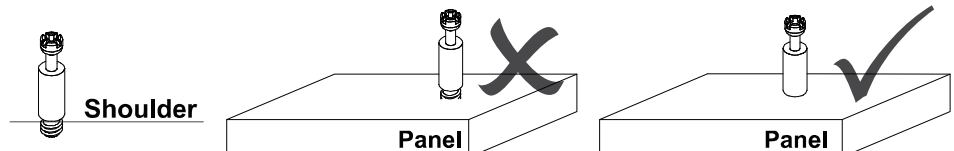



STEP 1

PARTS REQUIRED

4 - LEFT SIDE PANEL x1

HARDWARE REQUIRED

A  02
Ø6,0 x 10mm

H  02
10 x 10

L  02

Q  LEFT 01

TOOLS REQUIRED

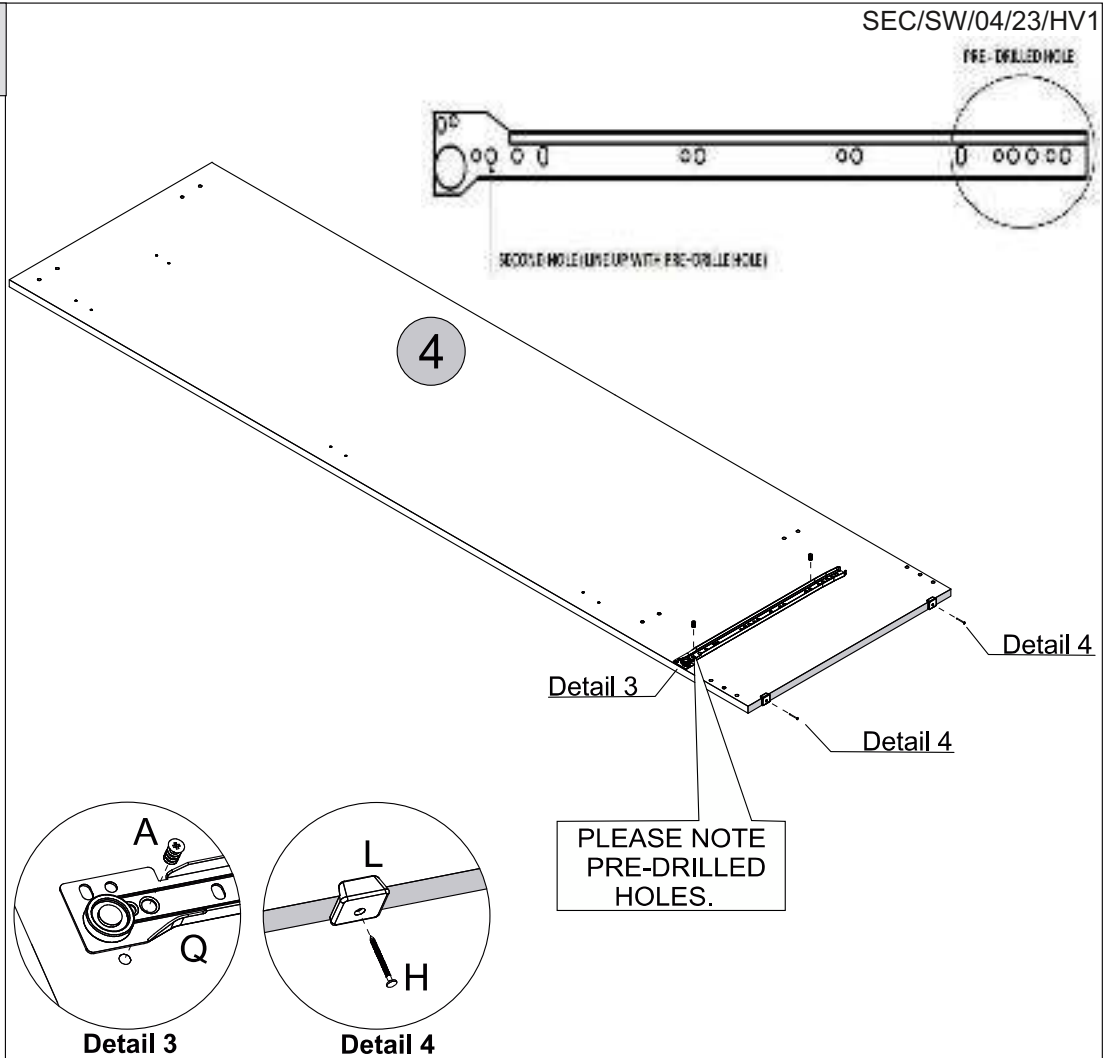
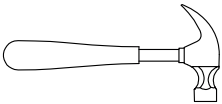
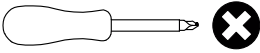

STEP 2

PARTS REQUIRED

6 - RIGHT SIDE PANEL x1

HARDWARE REQUIRED

A  02
Ø6,0 x 10mm

H  02
10 x 10

L  02

Q  RIGHT 01

TOOLS REQUIRED

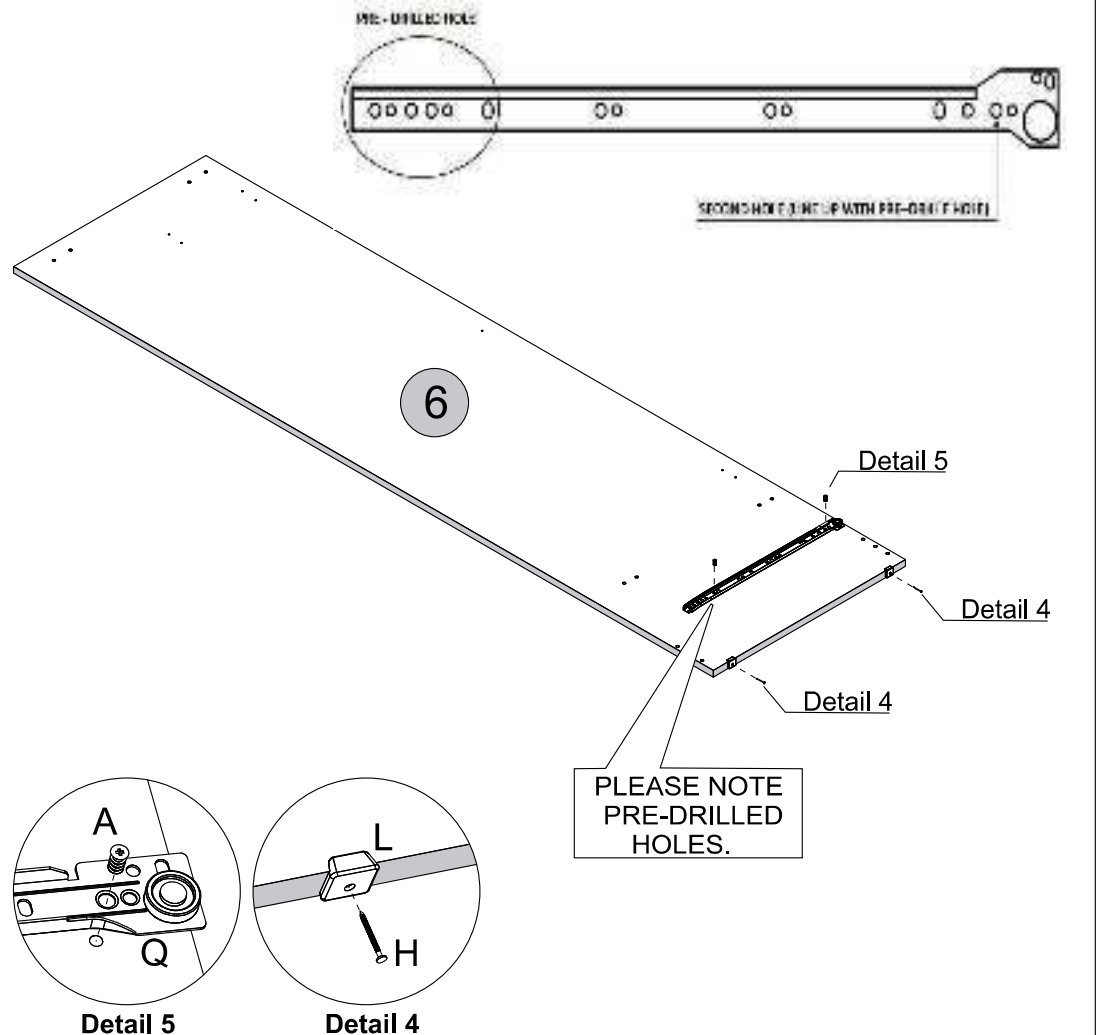
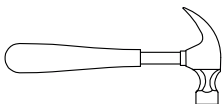
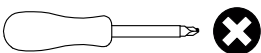



STEP 3

PARTS REQUIRED

4 - LEFT SIDE PANEL x1

HARDWARE REQUIRED

C  08
Ø4,0 x 14mm

M  01

P  03

TOOLS REQUIRED

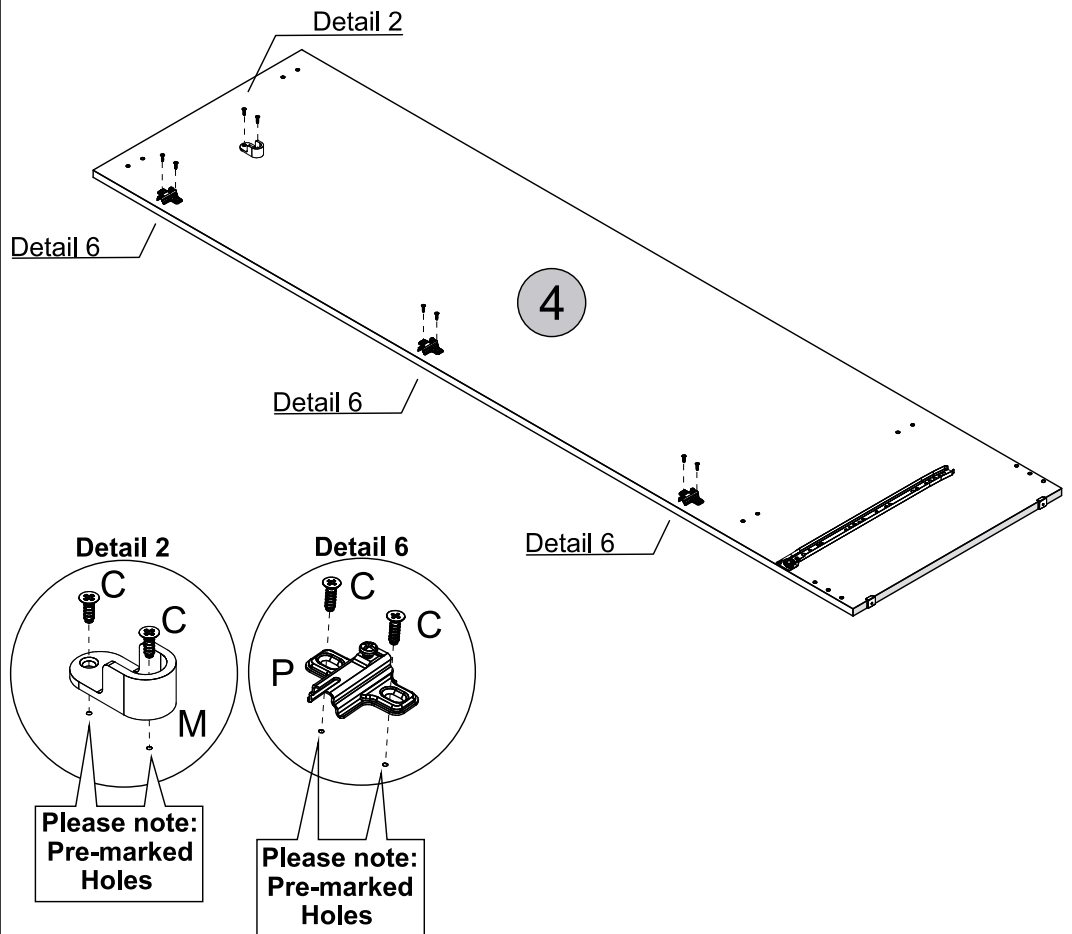
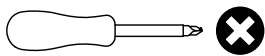

STEP 4

PARTS REQUIRED

6 - RIGHT SIDE PANEL x1

HARDWARE REQUIRED

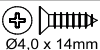
C  08
Ø4,0 x 14mm

M  01

P  03

TOOLS REQUIRED

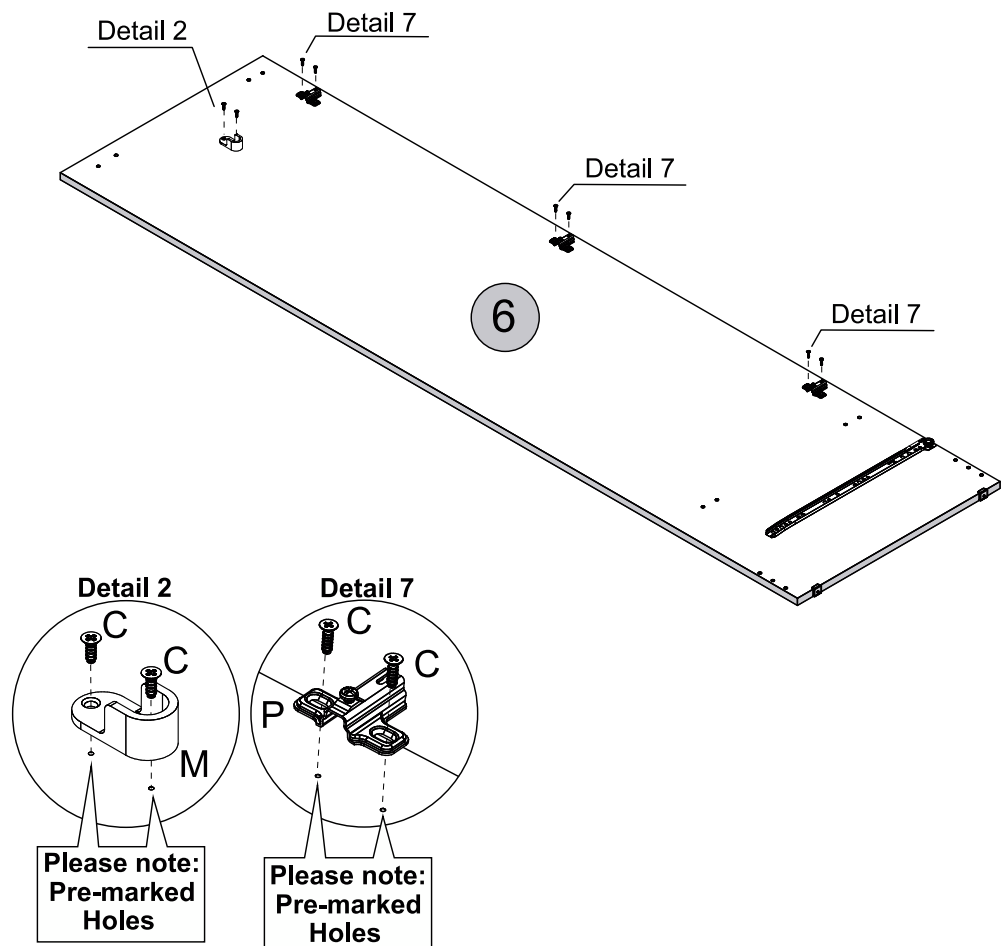
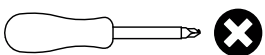

STEP 5

PARTS REQUIRED

1A - BASE PANEL x1

1B - TOP PANEL x1

HARDWARE REQUIRED

G  08
Ø6,0 x 30mm

J  02

V  01

Y  06
Ø4,0 x 12mm

Z  02

TOOLS REQUIRED

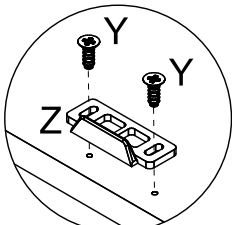
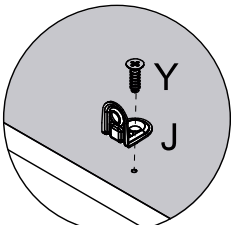
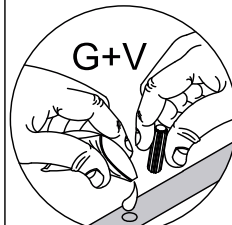
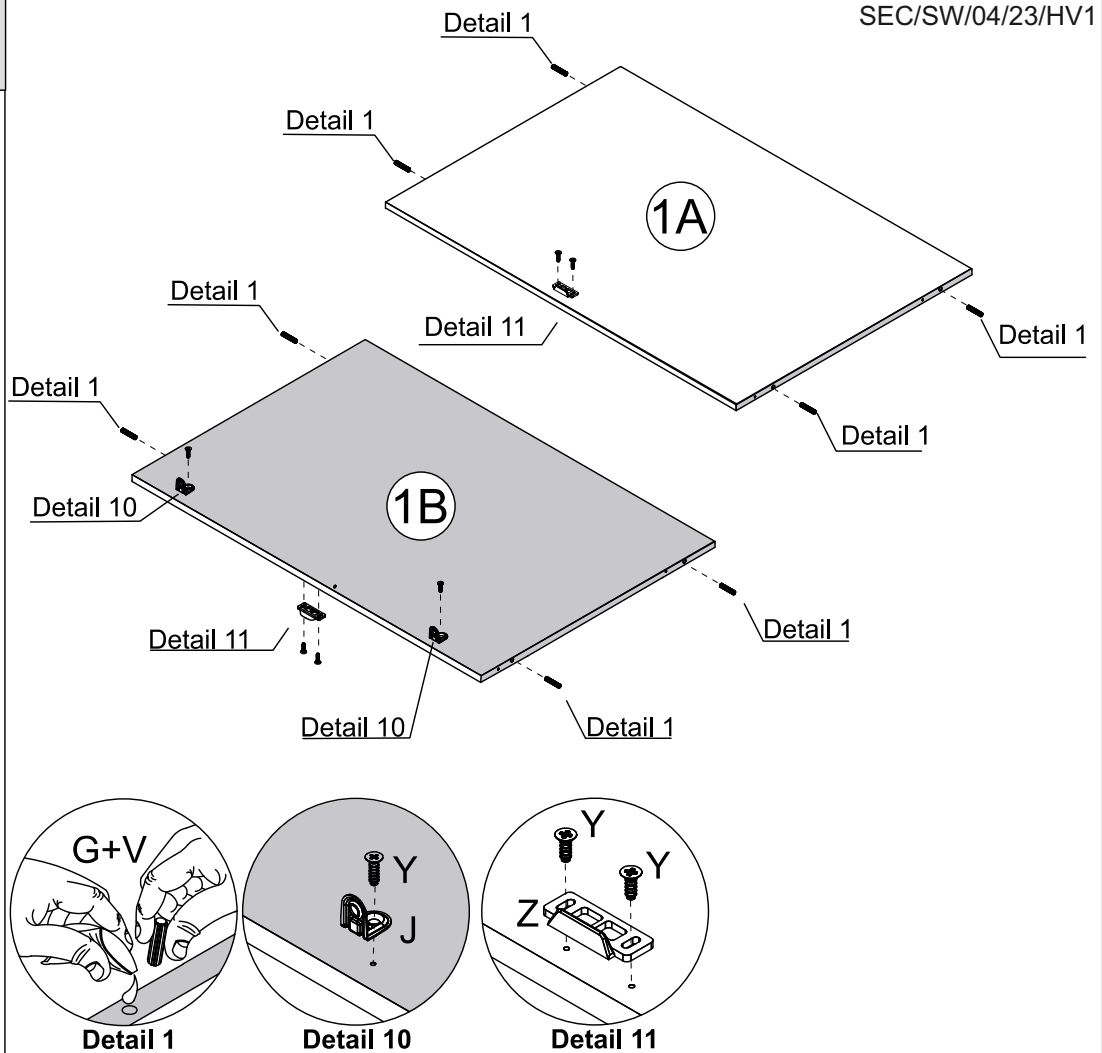
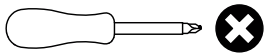

Detail 1

Detail 10

Detail 11

STEP 6

PARTS REQUIRED

7 - FRONT BASEBOARD x1

8 - BACK BASEBOARD x1

HARDWARE REQUIRED

G  08
Ø6,0 x 30mm

H  02
10 x 10

L  02

V  01

TOOLS REQUIRED

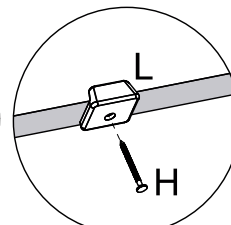
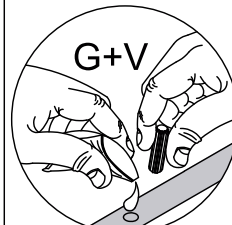
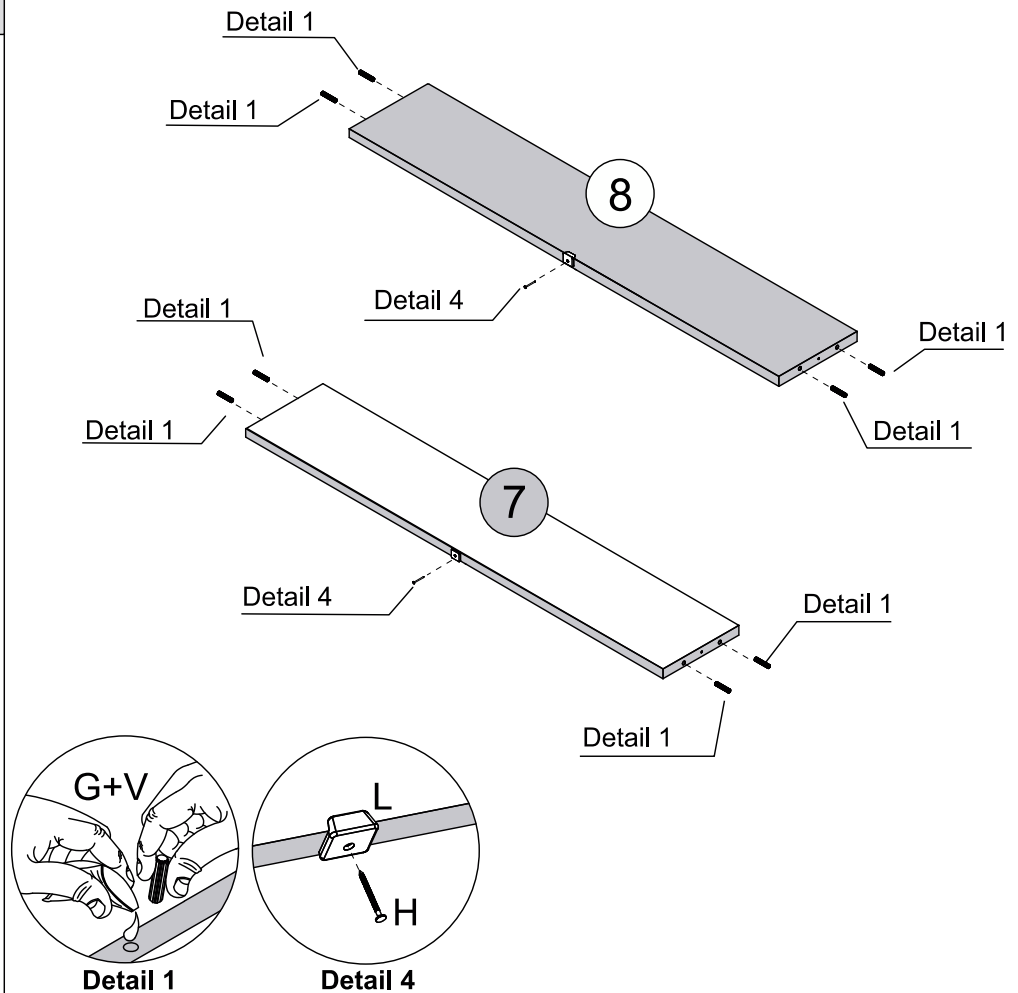
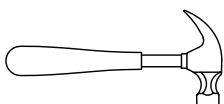

Detail 1

Detail 4

STEP 7

PARTS REQUIRED

1A - BASE PANEL x1

1B - TOP PANEL x1

6 - RIGHT SIDE PANEL x1

HARDWARE REQUIRED

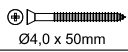
F  04
Ø4,0 x 50mm

V  01

TOOLS REQUIRED

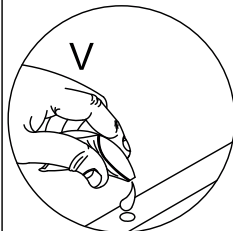
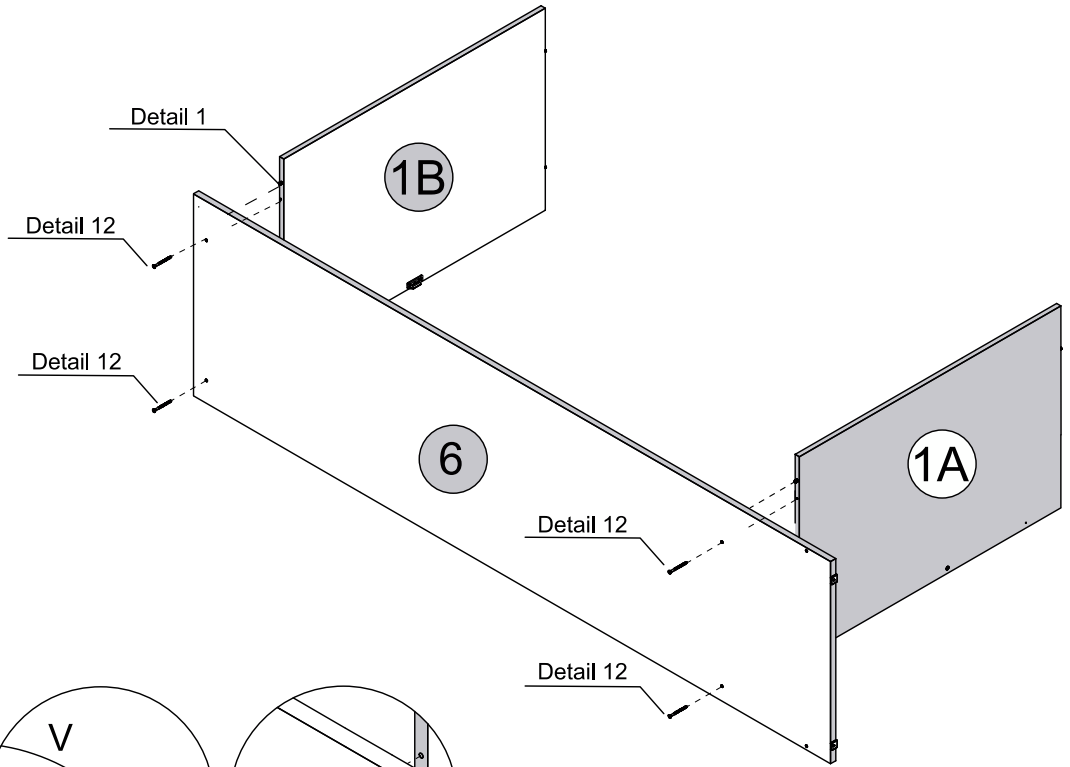
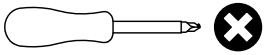

Detail 1

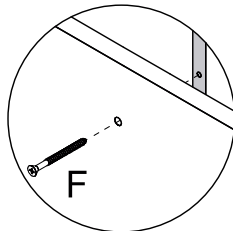

Detail 12

STEP 8

PARTS REQUIRED

4 - LEFT SIDE PANEL x1

7 - FRONT BASEBOARD x1

8 - BACK BASEBOARD x1

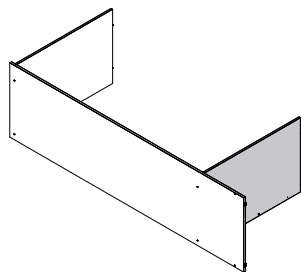

HARDWARE REQUIRED

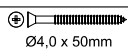
F  08
Ø4,0 x 50mm

V  01

TOOLS REQUIRED

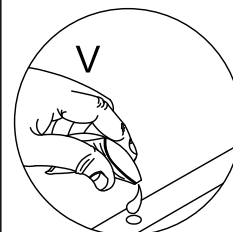
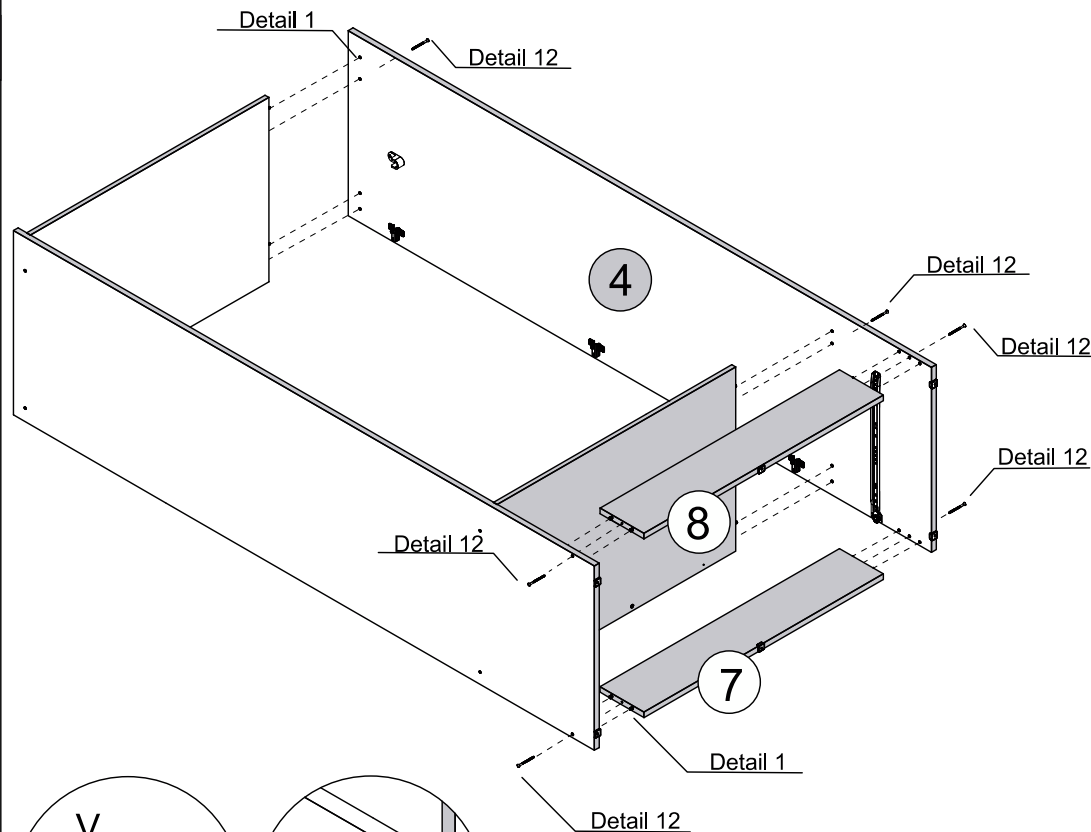
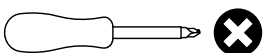

Detail 1

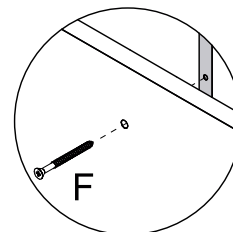

Detail 12

STEP 9

PARTS REQUIRED

9 - BACK PANEL x2

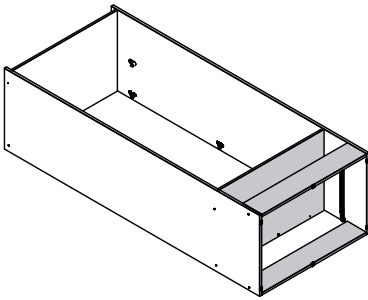

HARDWARE REQUIRED

B  06
Ø4,0 x 14mm

H  06
10 x 10

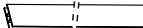
R  01

TOOLS REQUIRED

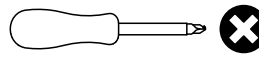
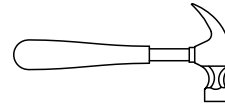

IMPORTANT PLEASE FOLLOW !

Please make sure Part 9 is lined up correctly at the top before placing fitting H into the panel as this can affect the alignment of the doors once assembled.

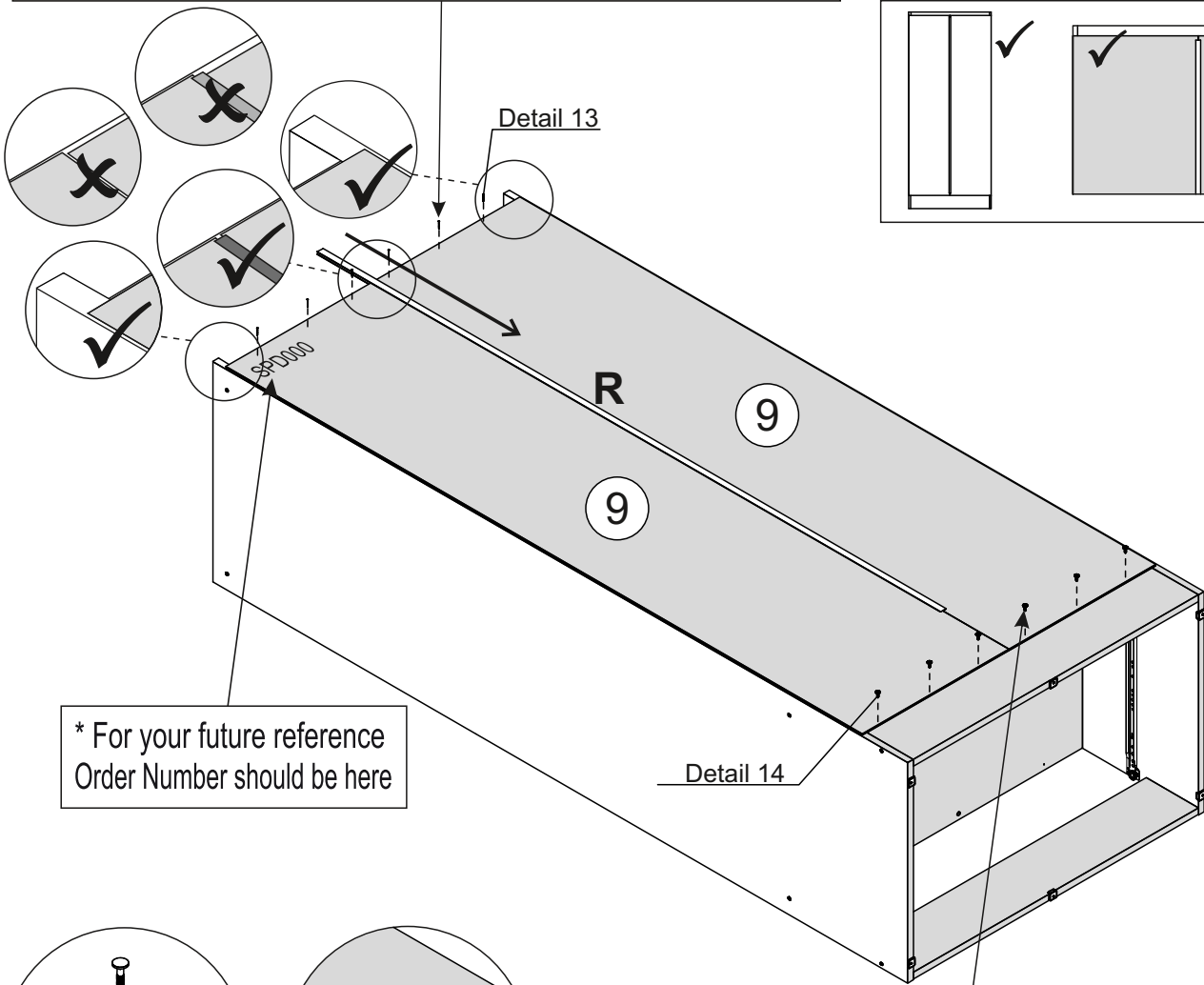
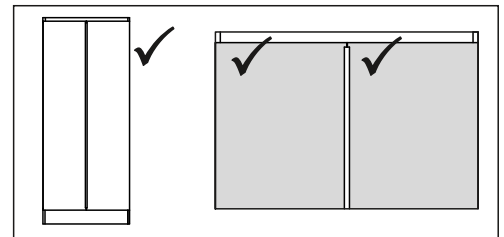
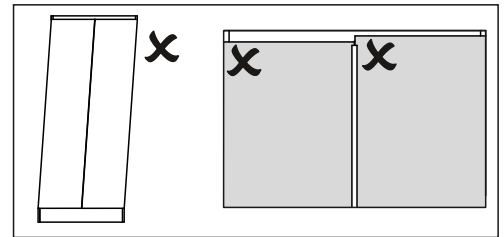

* For your future reference Order Number should be here

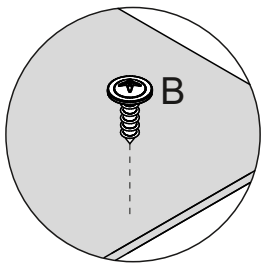
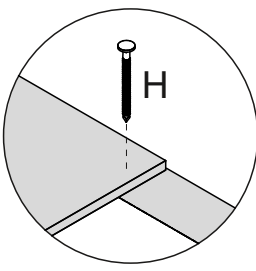

Detail 13

Detail 14

IMPORTANT PLEASE FOLLOW !

Please make sure Part 9 isn't overhanging at the sides before you screw fitting B into the plinth.

STEP 10

PARTS REQUIRED

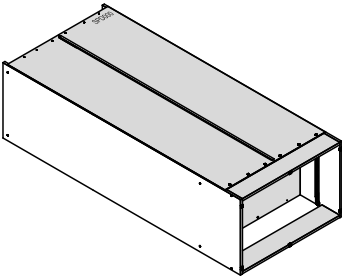

HARDWARE REQUIRED

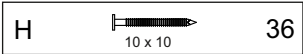

TOOLS REQUIRED

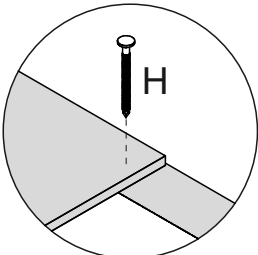
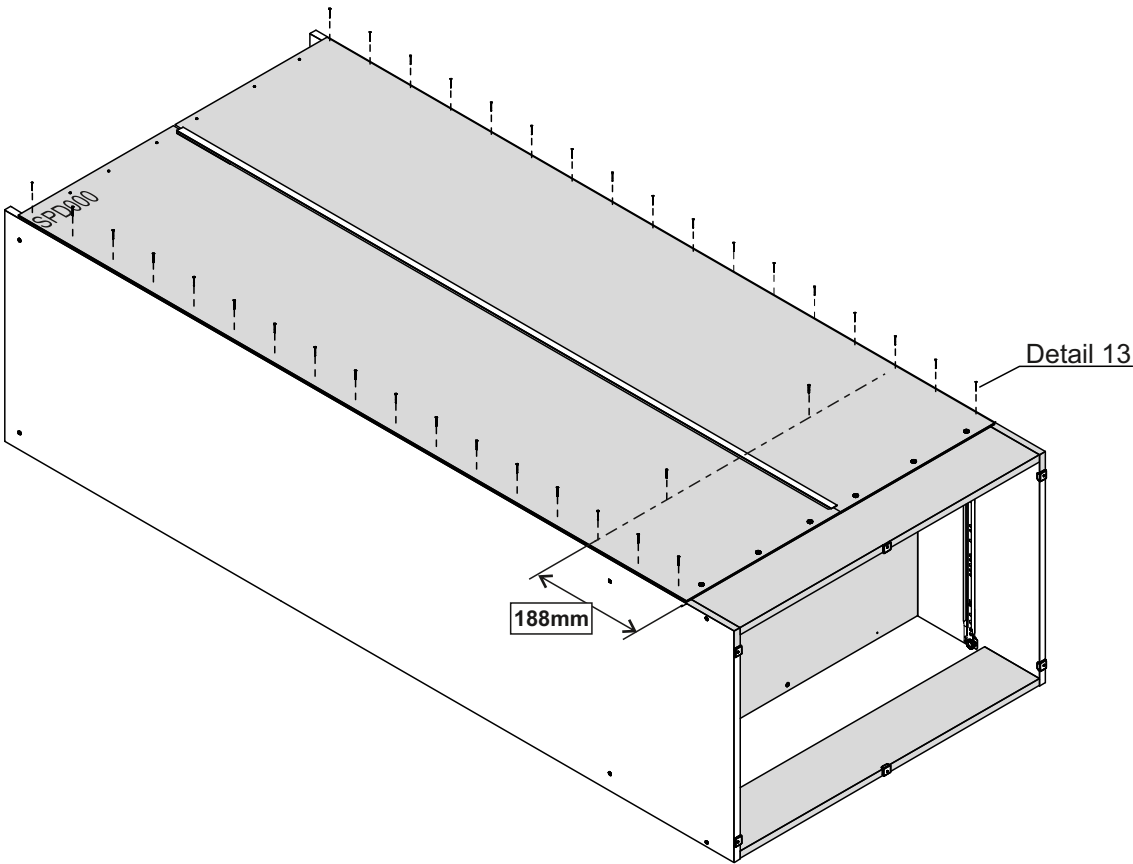
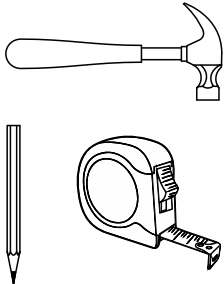

Detail 13

STEP 11

PARTS REQUIRED

10 - FRAME x1

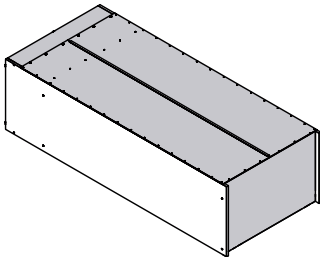

HARDWARE REQUIRED

J  02

Y  06
Ø4,0 x 12mm

TOOLS REQUIRED

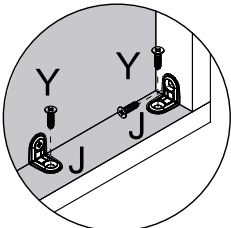
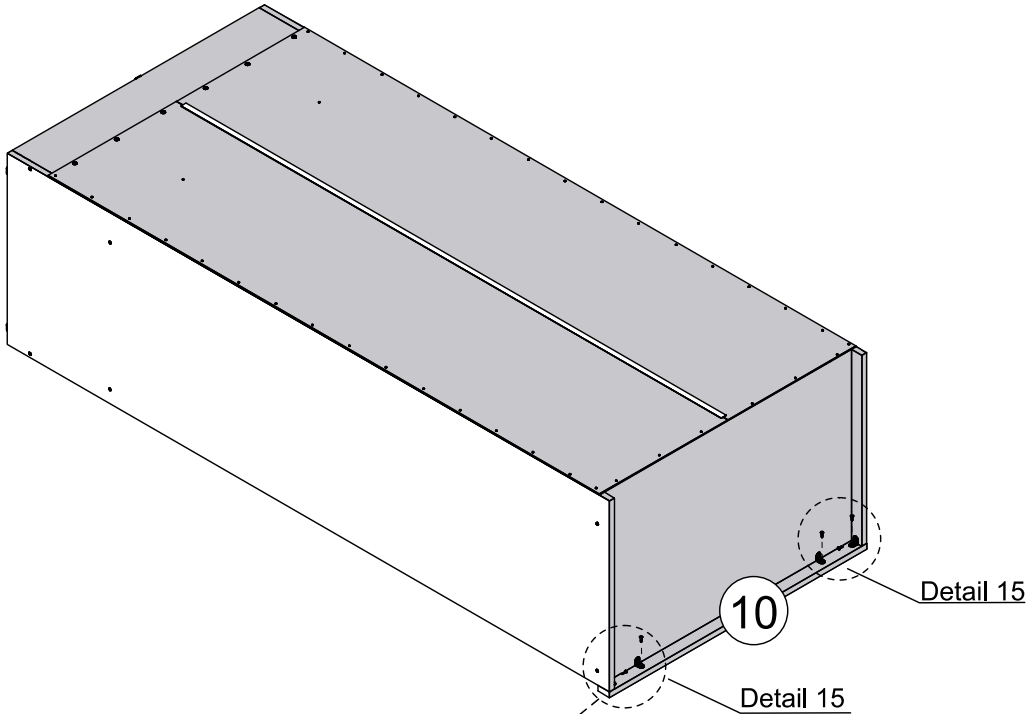
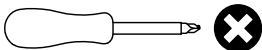

Detail 15

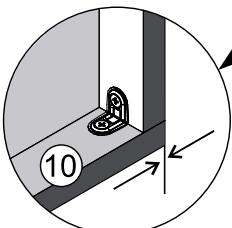

Align corners

STEP 12

PARTS REQUIRED

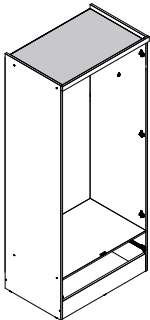

HARDWARE REQUIRED

N  01

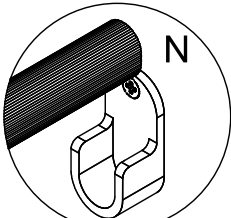
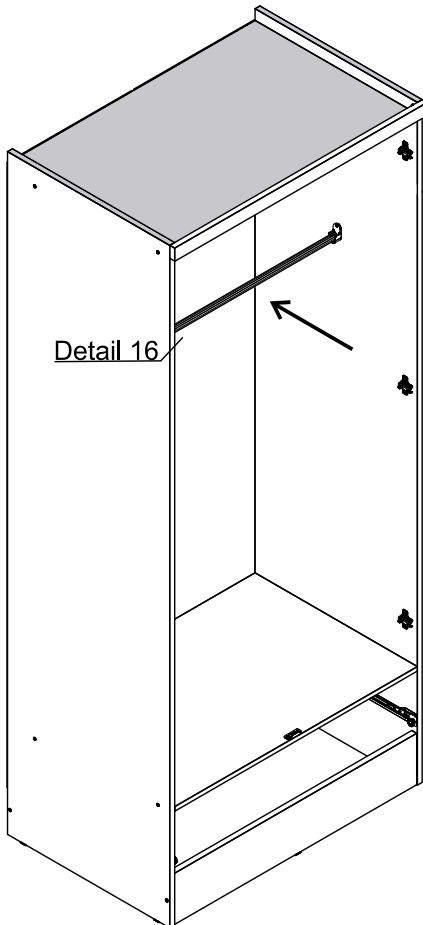

Detail 16

STEP 13

PARTS REQUIRED

15 - DRAWER SIDE x2

16 - DRAWER BACK PANEL x1

19 - DRAWER BOTTOM SUPPORT BAR x1

HARDWARE REQUIRED

G  10
Ø6,0 x 30mm

V  01
Glue

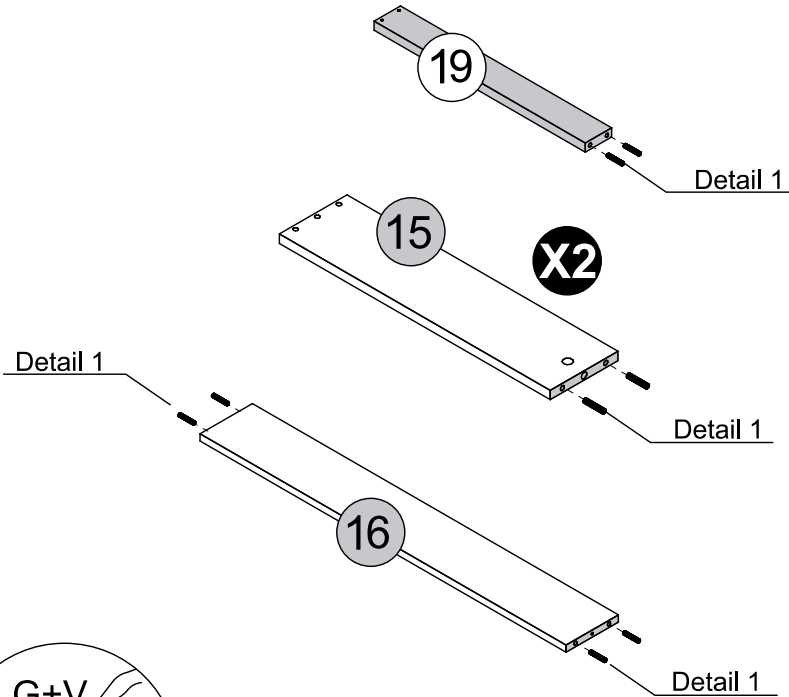

Detail 1

STEP 14

PARTS REQUIRED

17 - DRAWER FRONT x1

HARDWARE REQUIRED

X  02

TOOLS REQUIRED

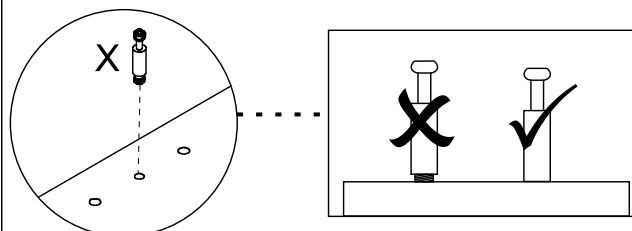
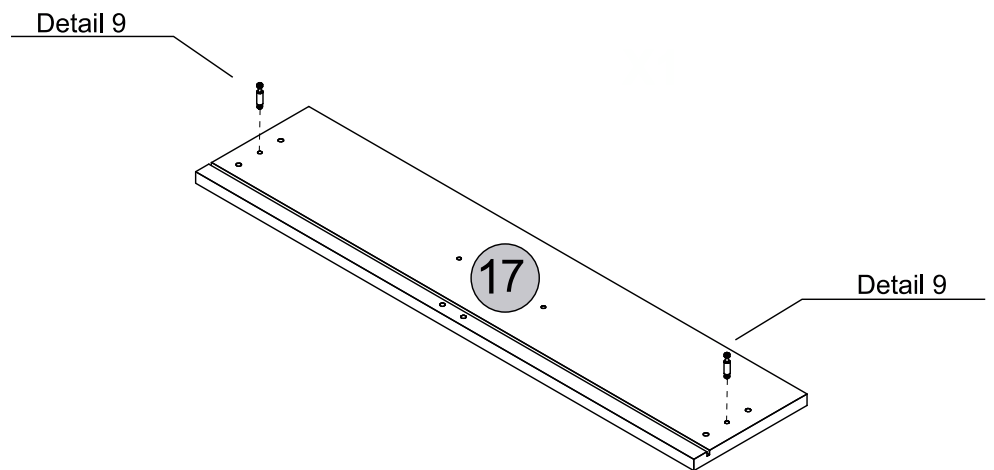
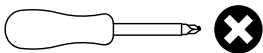

Detail 9

STEP 15

PARTS REQUIRED

15 - DRAWER SIDE x2

16 - DRAWER BACK PANEL x1

HARDWARE REQUIRED

F  02
Ø4,0 x 50mm

TOOLS REQUIRED

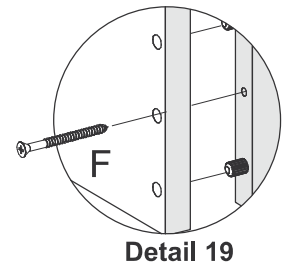
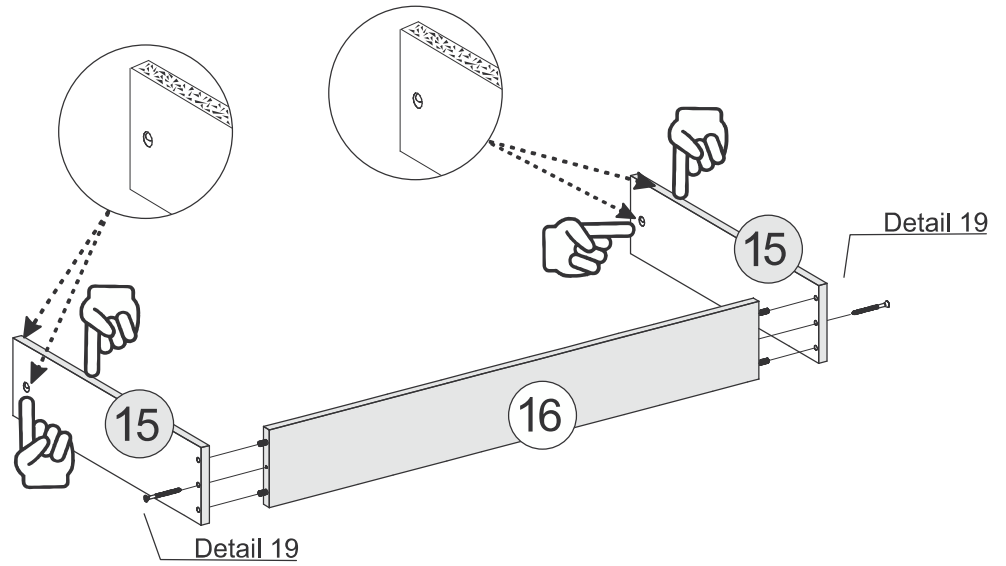
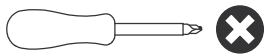

STEP 16

PARTS REQUIRED

17 - DRAWER FRONT x1

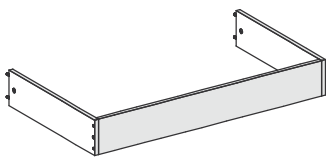

HARDWARE REQUIRED

A1  02

V  01

W  02

TOOLS REQUIRED

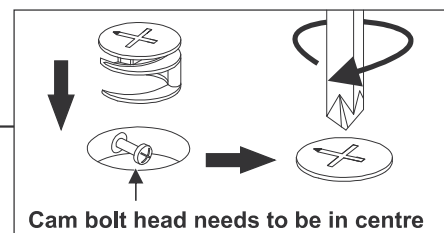
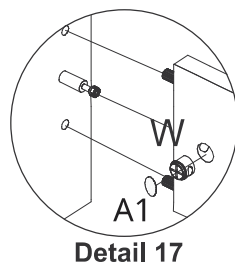
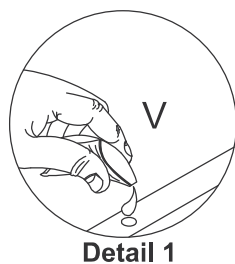
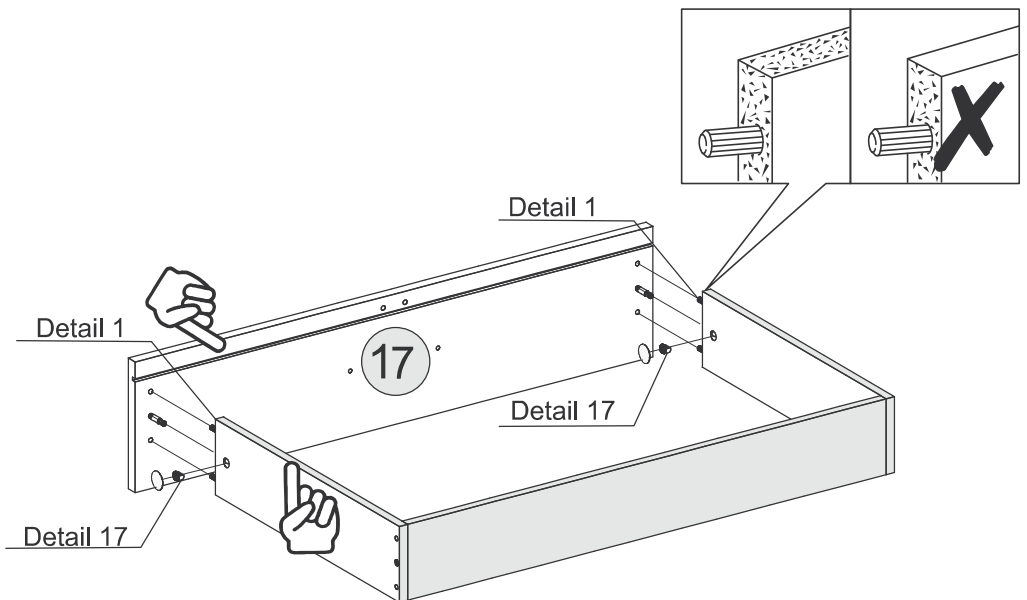
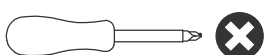

STEP 17

PARTS REQUIRED

18 - DRAWER BOTTOM x1

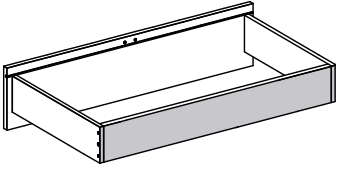

HARDWARE REQUIRED

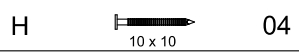

TOOLS REQUIRED

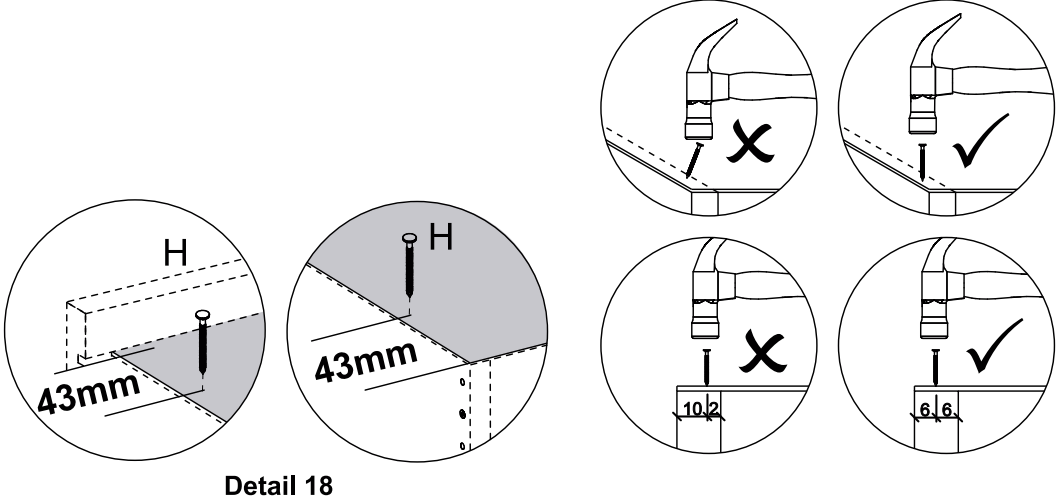
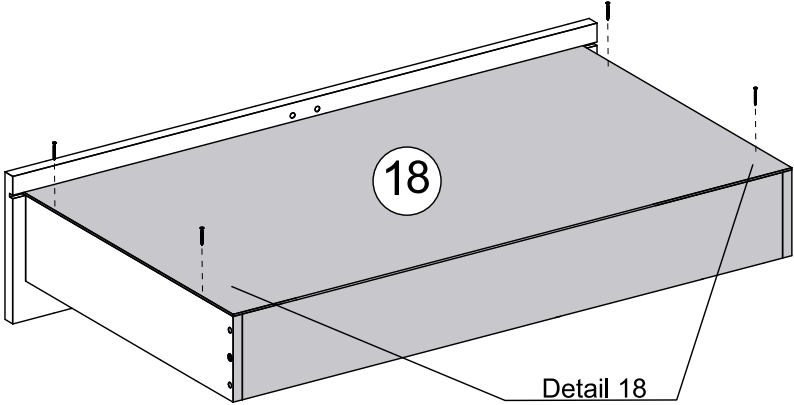
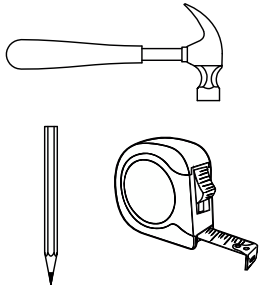

STEP 18

PARTS REQUIRED

19 - DRAWER BOTTOM SUPPORT BAR x1

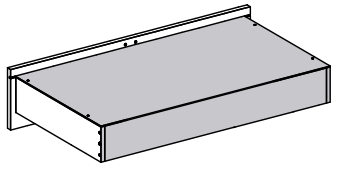

HARDWARE REQUIRED

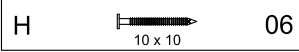

TOOLS REQUIRED

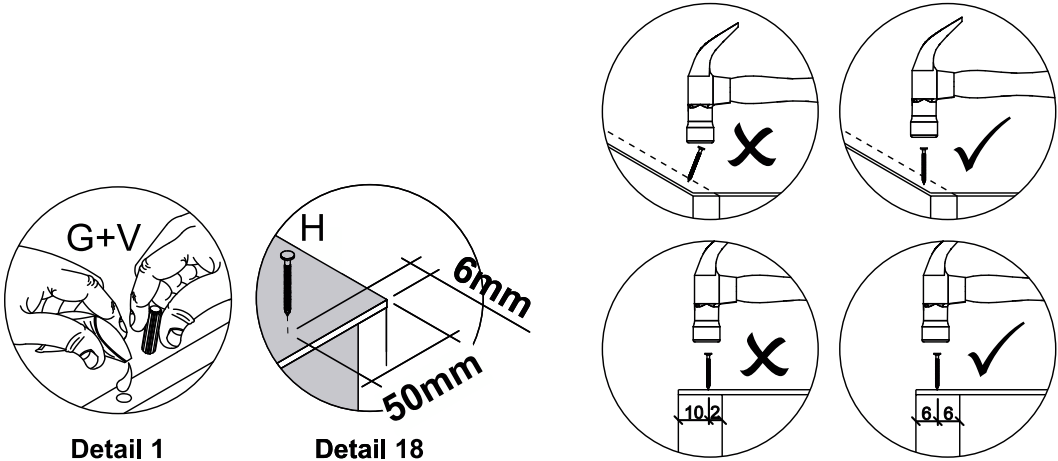
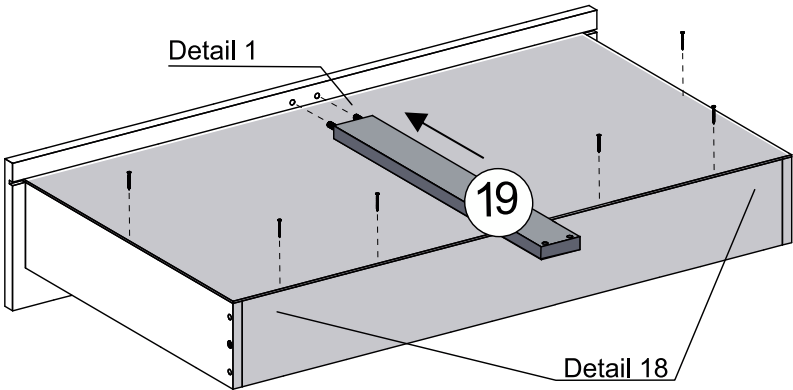
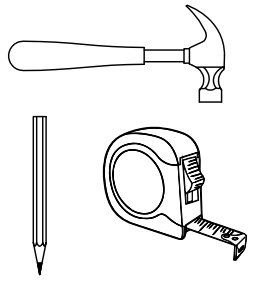

STEP 19

PARTS REQUIRED

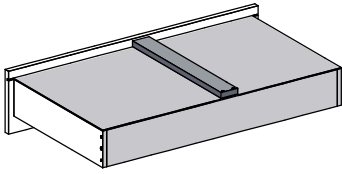

HARDWARE REQUIRED

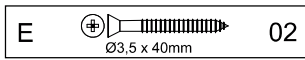
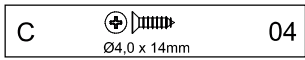

TOOLS REQUIRED

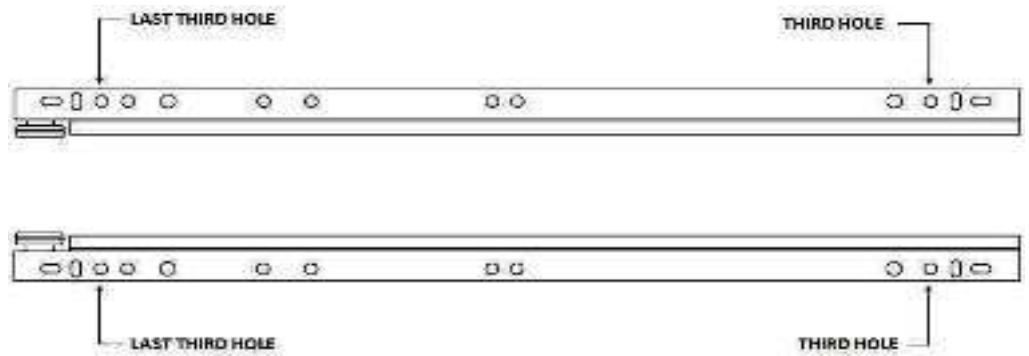
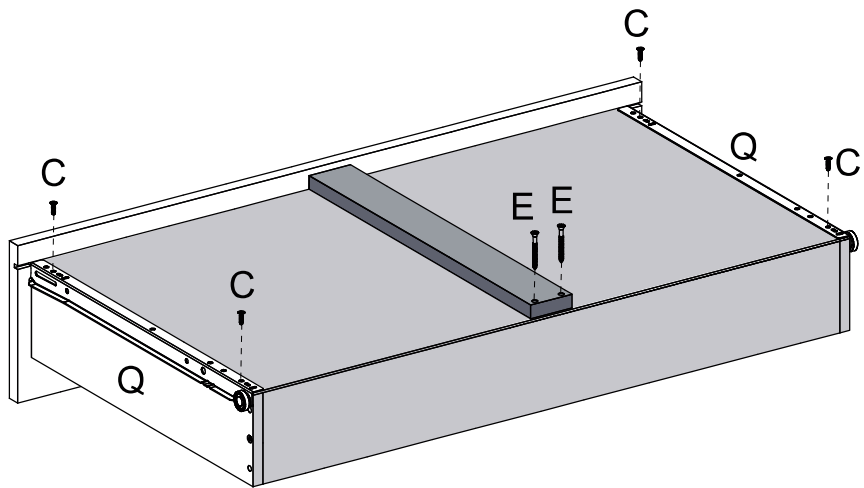
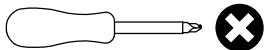

STEP 20

PARTS REQUIRED



HARDWARE REQUIRED

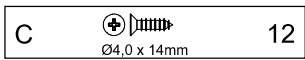

TOOLS REQUIRED

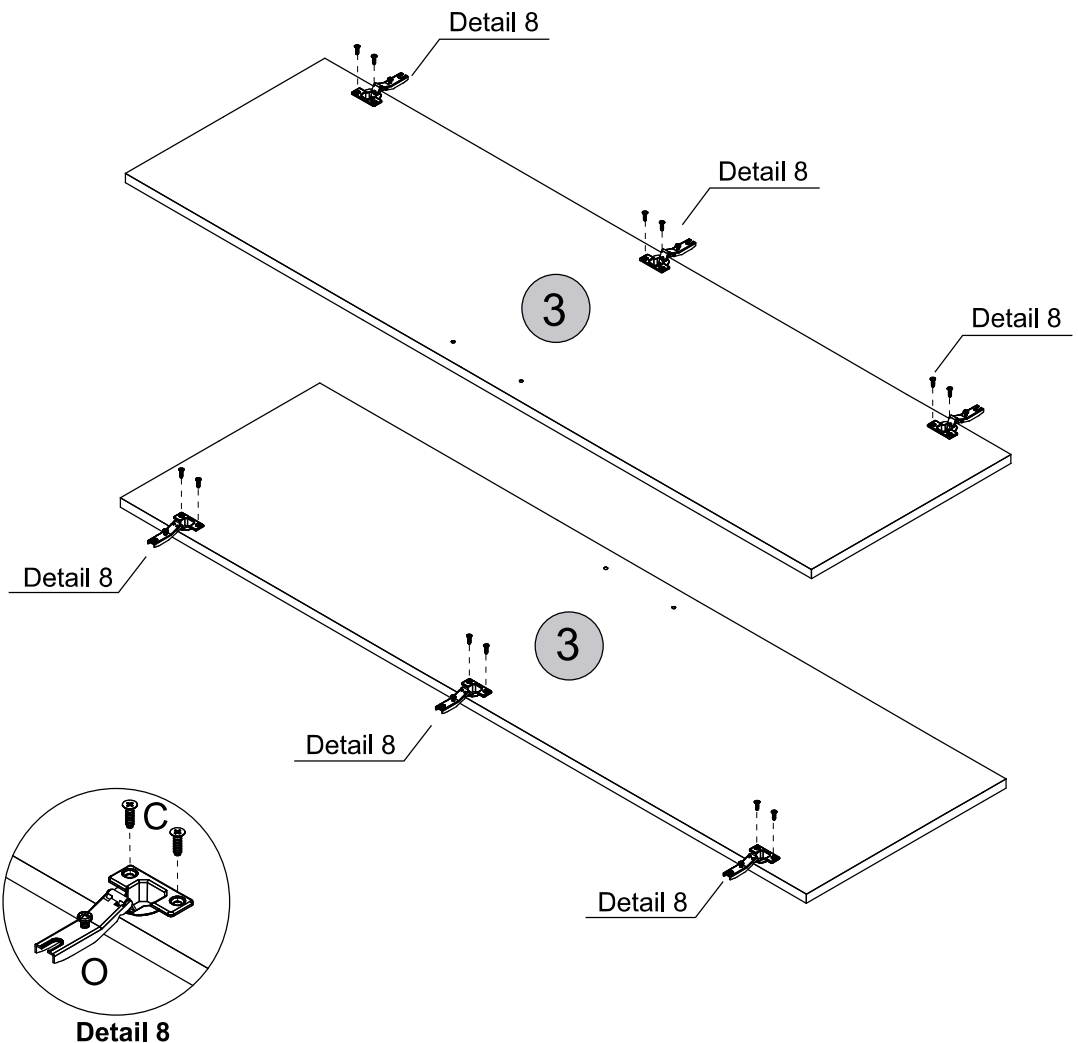
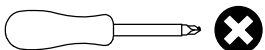

STEP 21

PARTS REQUIRED

3 - DOOR x2

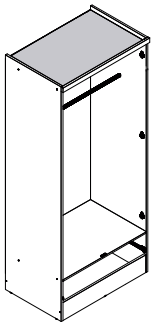

HARDWARE REQUIRED

U  12

TOOLS REQUIRED

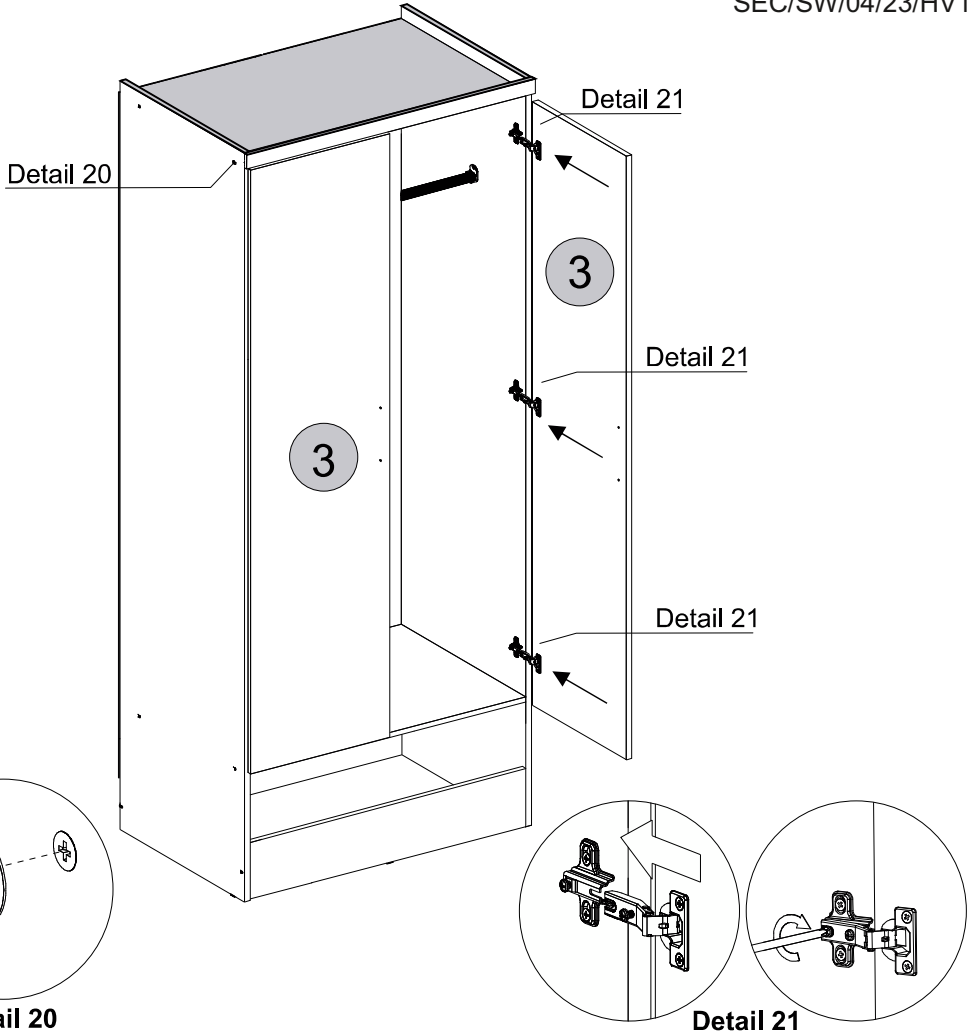
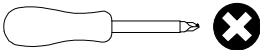

STEP 22

PARTS REQUIRED

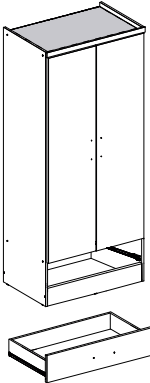

HARDWARE REQUIRED

D  Ø4,0 x 22mm 06

T  03

TOOLS REQUIRED

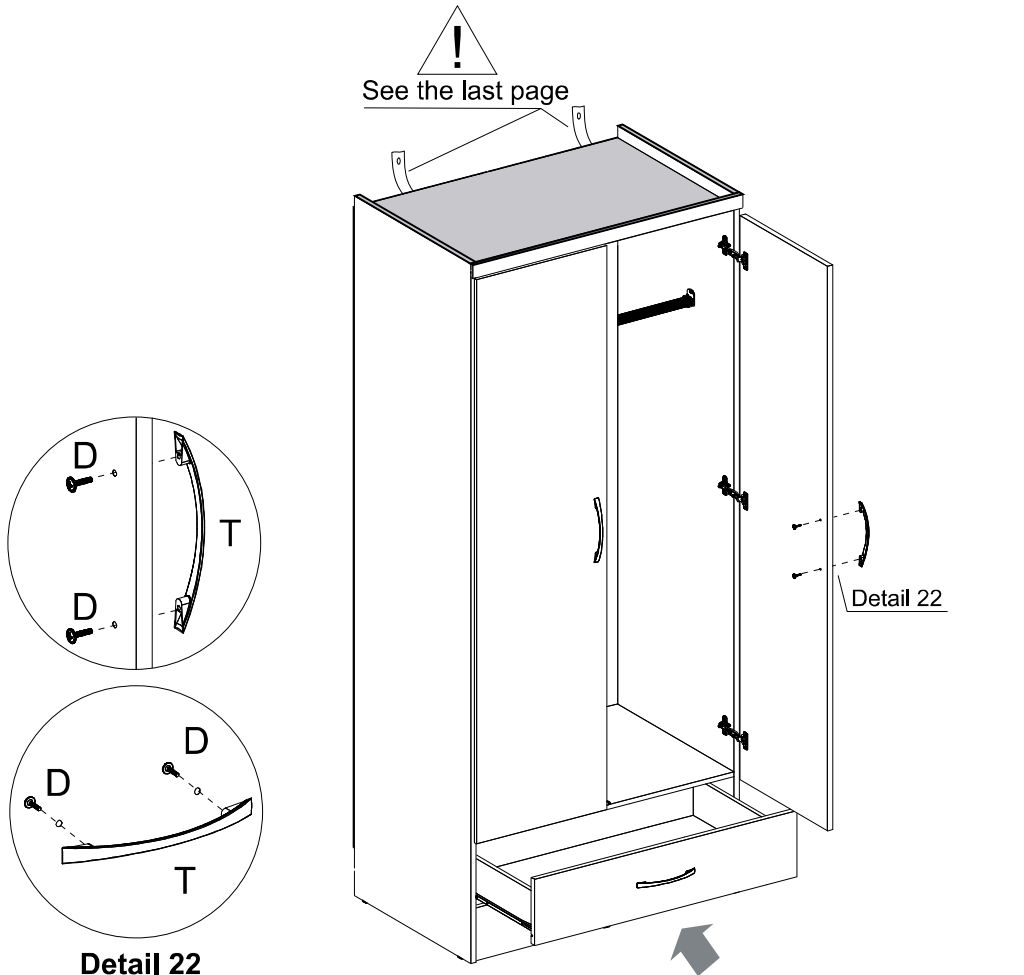
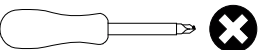

STEP 23

PARTS REQUIRED

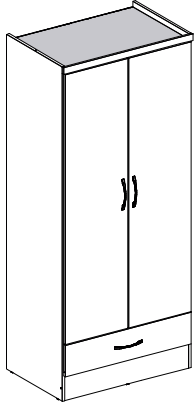

HARDWARE REQUIRED

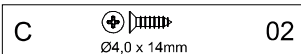

TOOLS REQUIRED

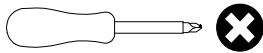

TIP
If desired, after assembly use an alcohol cleaner to erase the number printed on the parts.

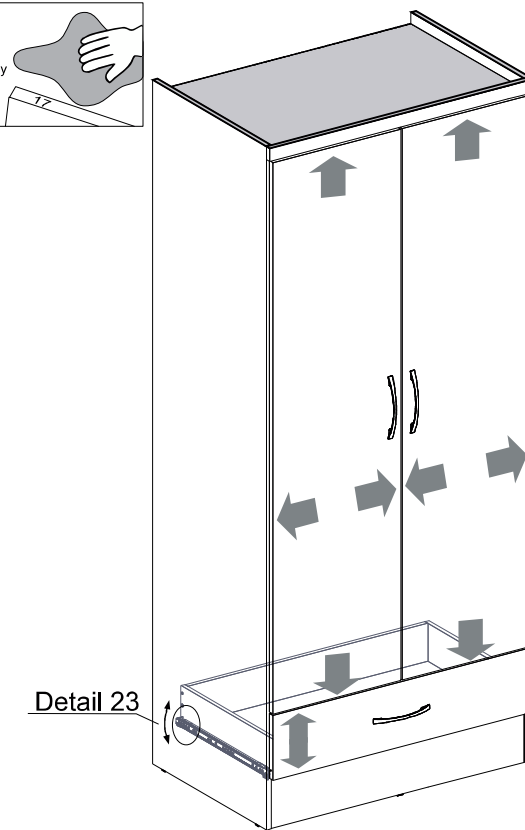

Detail 23

Drawer Adjustment Drawer Lock

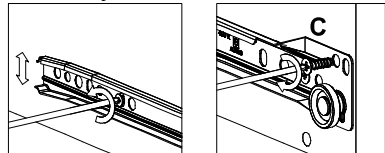

Detail 23

Height Adjustment

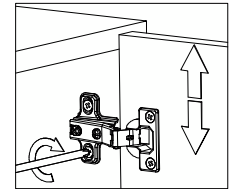

Internal Adjustment

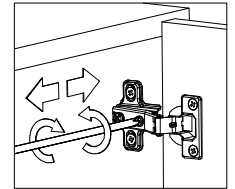

Depth Adjustment

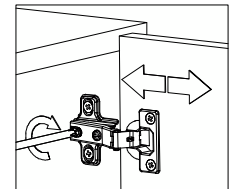
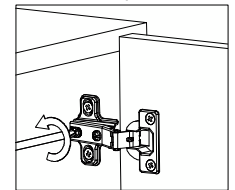

WARNING

Serious or fatal injuries can occur from furniture tipping over. To prevent the furniture from tipping over we recommend that it is permanently fixed to the wall.

Wall fixings are not supplied with this product as different wall materials require different types of fixing devices. Please make sure you use fixings suitable for the walls in your home.

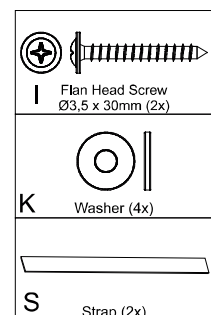
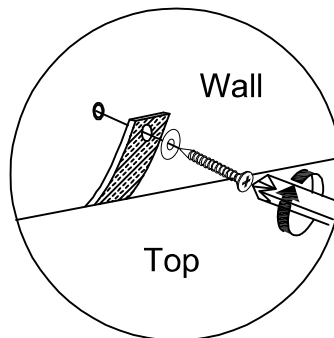
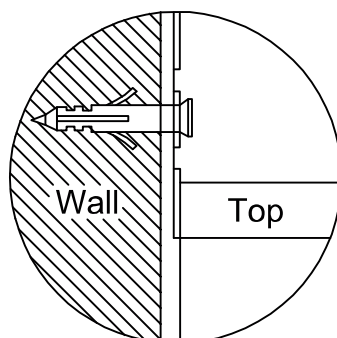
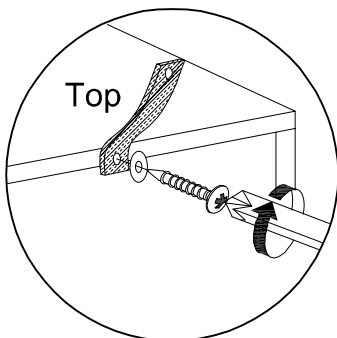

NEVADA 3+2 DRAWER CHEST ASSEMBLY INSTRUCTIONS

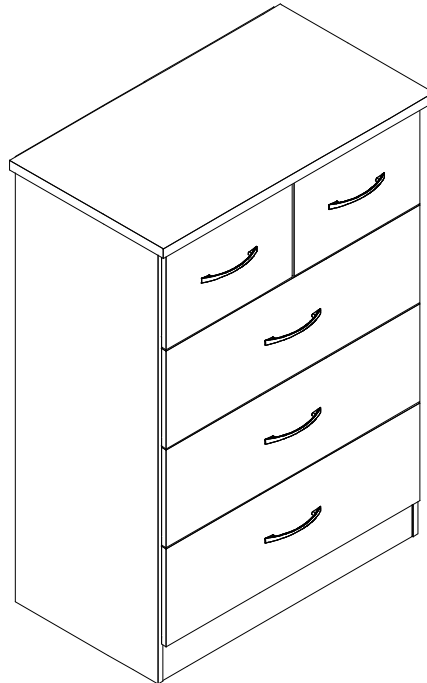

IMPORTANT FOR DOMESTIC USE ONLY PLEASE READ BEFORE YOU CONTINUE FURTHER CARE AND MAINTENANCE

After unpacking this product please keep the original packaging in case it needs to be returned for any reason.

- Please ensure all fittings and parts are present before commencing with assembly.
- Never drag or push products as this could cause damage to the joints making it inferior.
- We strongly recommend that you keep children away from your work area.
- We recommend that you lay a blanket or sheet on the floor to avoid damage to both your floor and the product.
- Assemble this product as close to its final position as possible.
- Do not place this product next to a radiator or in direct sunlight.
- Do not drag or push items across your high gloss furniture as this may cause the surface to scratch
- Wood is a natural product and may expand if subjected to damp and may shrink or crack if subjected to heat. Therefore it is recommended that room temperature is maintained, with no sudden temperature fluctuations.
- Make sure any spillage is wiped off immediately.
- Do not place hot or chilled items directly on to the surface, use a place mat or marking will occur.
- For general cleaning use a soft cotton or micro fibre cloth, and do not use detergents of any kind.
- From time to time it may be necessary to tighten fittings, regular inspections should be carried out.
- Do not place on a wet or damp floor as staining may occur to your floor.

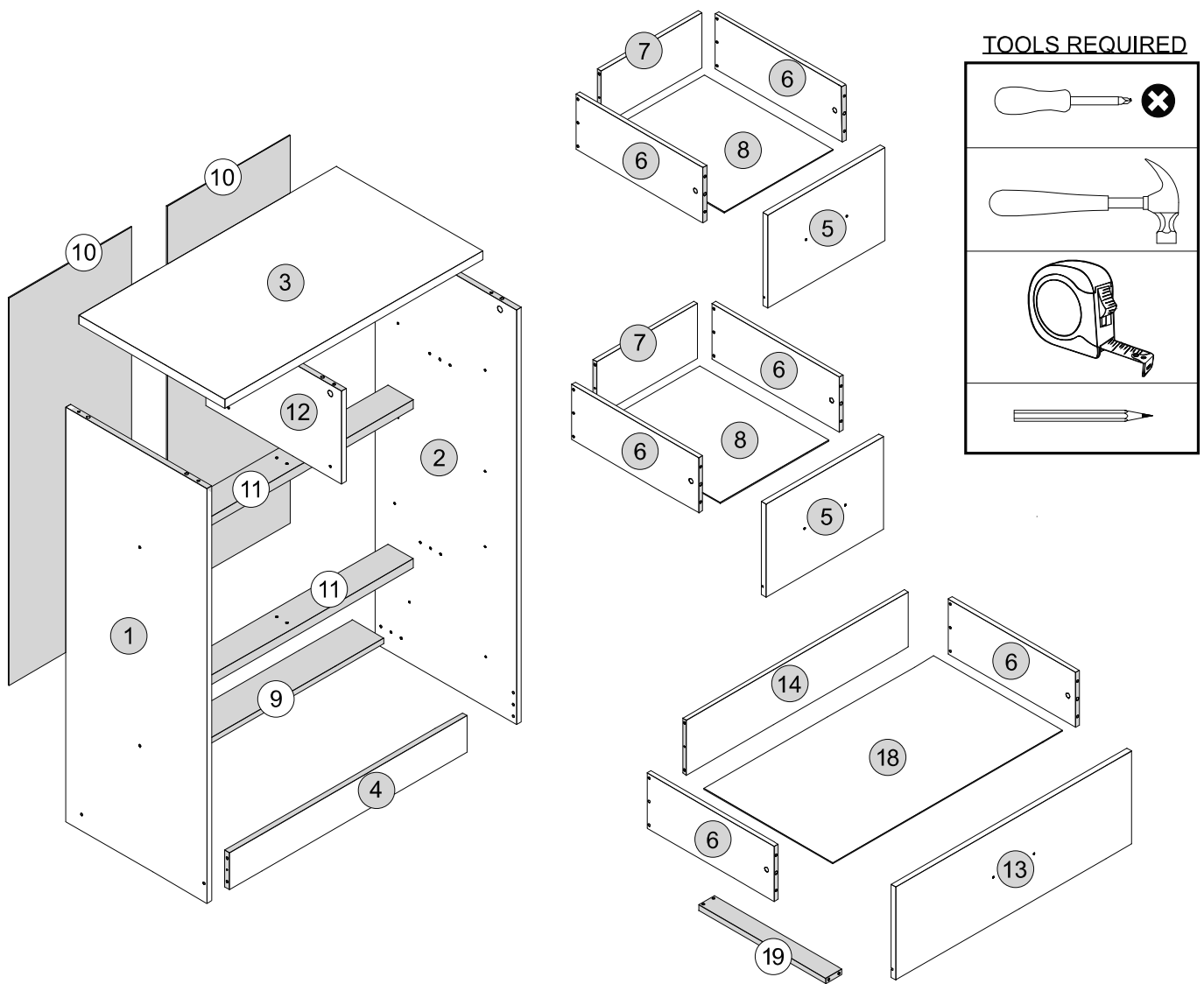









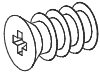
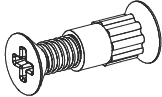
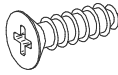
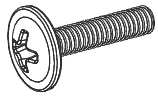
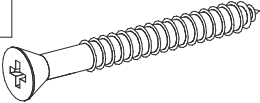
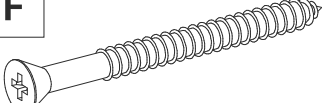
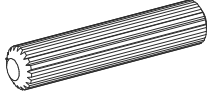

PARTS LIST

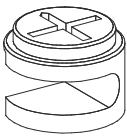
Please Note:
The below parts have all been stamped with the part number to help identify them during assembly.

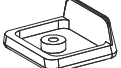
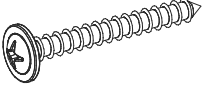
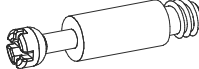
Part Number	Part Description	Quantity	Carton
01	Left Side Panel	1	1/2
02	Right Side Panel	1	1/2
03	Top Panel	1	2/2
04	Front Baseboard	1	1/2
05	Small Drawer Front	1	2/2
06	Drawer Side	10	1/2
07	Small Drawer Back Panel	2	1/2
08	Small Drawer Bottom	2	1/2
09	Back Baseboard	1	1/2
10	Back Panel	1	1/2
11	Crossbar	2	2/2
12	Division Panel	1	1/2
13	Large Drawer Front	3	2/2
14	Large Drawer Back Panel	3	1/2
18	Large Drawer Bottom	3	2/2
19	Drawer Bottom Support Bar	3	1/2

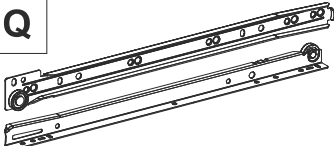
FITTINGS LIST

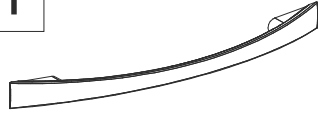
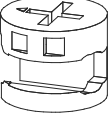
SEC/SH/09/21/HV1

<p>A</p>  <p>Flat Head Screw 2/+ Ø6,0 x 10mm (16x)</p>	<p>B</p>  <p>Double Flat Head Screw 1/+ Ø4,0 x 18mm (2x)</p>	<p>C</p>  <p>Flat Head Screw 2/+ Ø4,0 x 14mm (30x)</p>	<p>D</p>  <p>Flan Head Screw 2/+ Ø4,0 x 20mm (10x)</p>
<p>E</p>  <p>Flat Head Screw 1/+ Ø3,5 x 40mm (6x)</p>	<p>F</p>  <p>Flat Head Screw 2/+ Ø4,0 x 50mm (19x)</p>	<p>G</p>  <p>2/+ Dowel Ø6,0 x 30mm (69x)</p>	<p>H</p>  <p>2/+ Nail 10x10 Ringed-1,5x23mm (84x)</p>
<p>I</p>  <p>1/+ Back Panel Bracket 14x14mm (2x)</p>	<p>J</p>  <p>2/+ Cam Nut Ø12x8,8MM (10x)</p>	<p>K</p>  <p>1/+ Washer Ø16x7 (4x)</p>	<p>L</p>  <p>1/+ Plastic Foot L 19x17x8mm Ø2 (6x)</p>
<p>M</p>  <p>Flan Head Screw 1/+ Ø3,5 x 30mm (2x)</p>	<p>N</p>  <p>2/+ Cam Bolt (16x)</p>	<p>O</p>  <p>2/+ Hole Plugs 19MM (9x)</p>	<p>P</p>  <p>Glue 10Gr (3x)</p>
<p>Q</p>  <p>Drawer Runners 400MM (5x)</p>	<p>R</p>  <p>Back Panel Strip H 799x19x3,8mm (1x)</p>	<p>S</p>  <p>Strap 200x20x1MM (2x)</p>	<p>T</p>  <p>Handle (5x)</p>
<p>U</p>  <p>1/+ Cam Nut Ø14,9x11MM (6x)</p>	<p>V</p>  <p>+2 Hole Plugs Líneo 19mm (9x)</p>		

TIPS FOR FITTINGS CAM-LOCKS

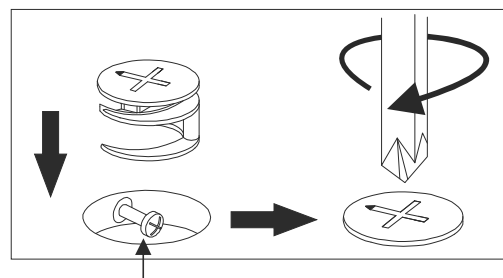
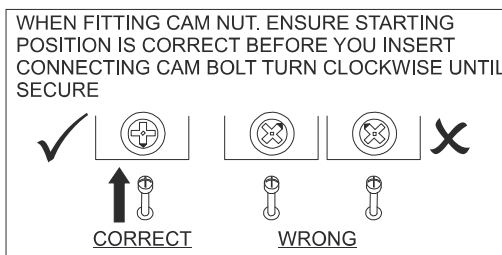

CAMBOLT

Tighten until shoulder is flush with panel. Do not overtighten or undertighten (see example below)

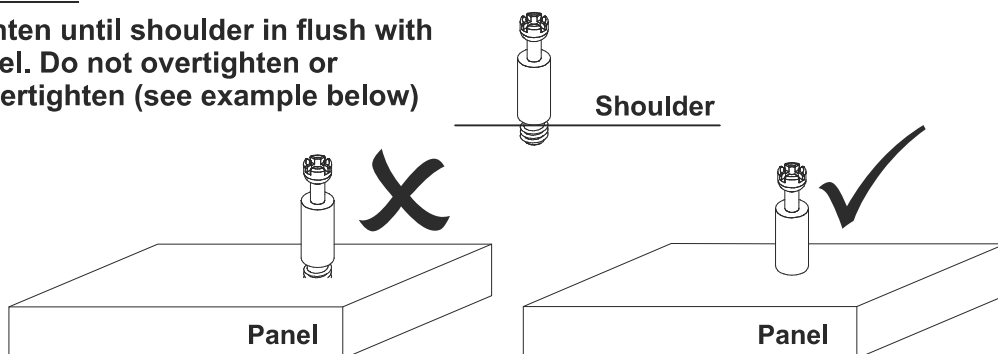

STEP 1

PARTS REQUIRED

1 - LEFT SIDE PANEL x1

HARDWARE REQUIRED

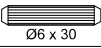
G  02
Ø6 x 30

H  02
10 x 10

L  02

P  01
GLUE

TOOLS REQUIRED

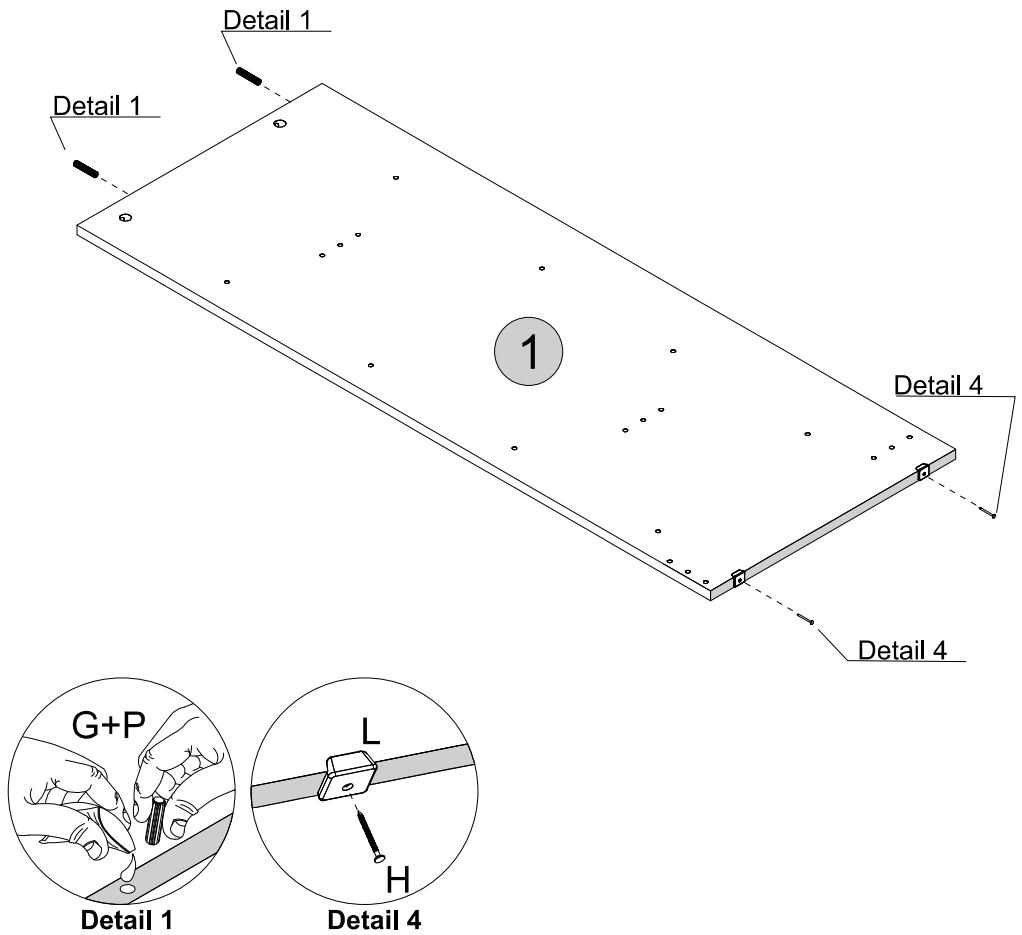
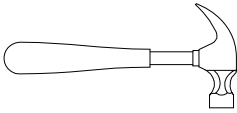



STEP 2

PARTS REQUIRED

2 - RIGHT SIDE PANEL x1

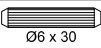
HARDWARE REQUIRED

G  02
Ø6 x 30

H  02
10 x 10

L  02

P  01
GLUE

TOOLS REQUIRED

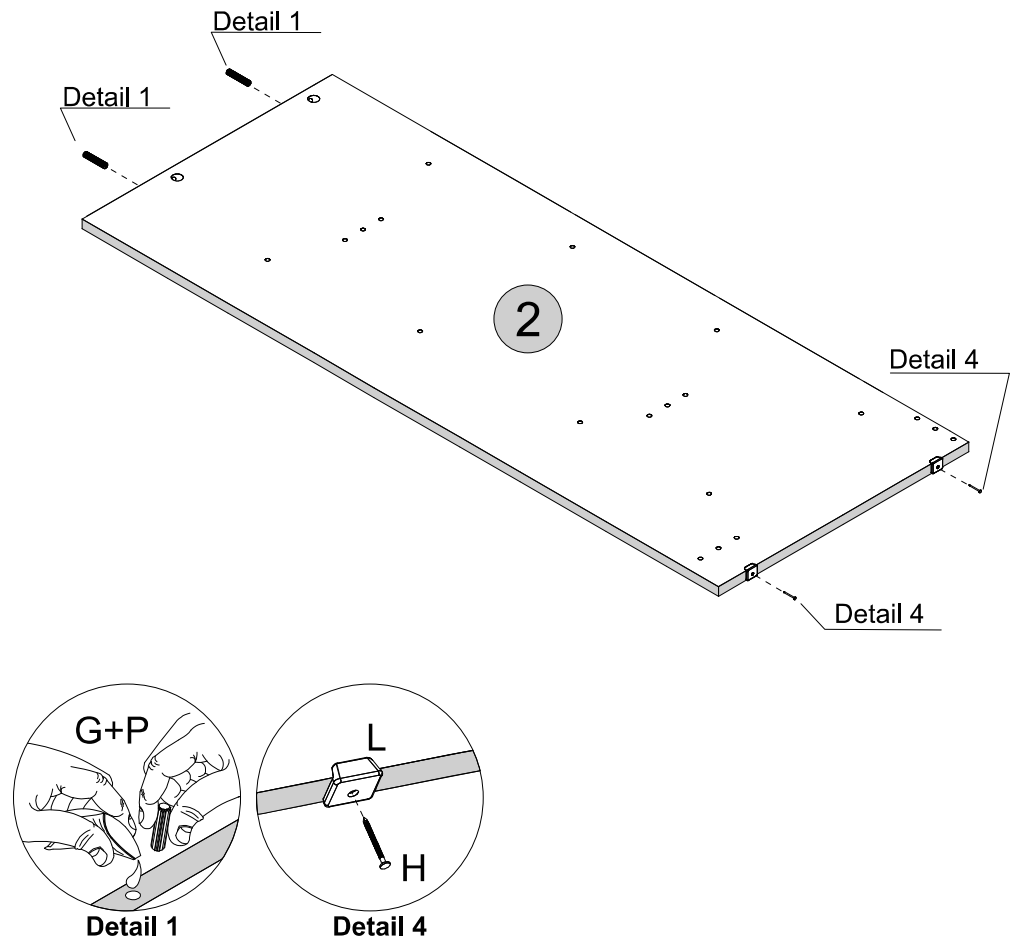
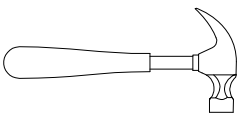



STEP 3

PARTS REQUIRED

1 - LEFT SIDE PANEL x1

HARDWARE REQUIRED

A  08
Ø6 x 10

Q  04
LEFT

TOOLS REQUIRED

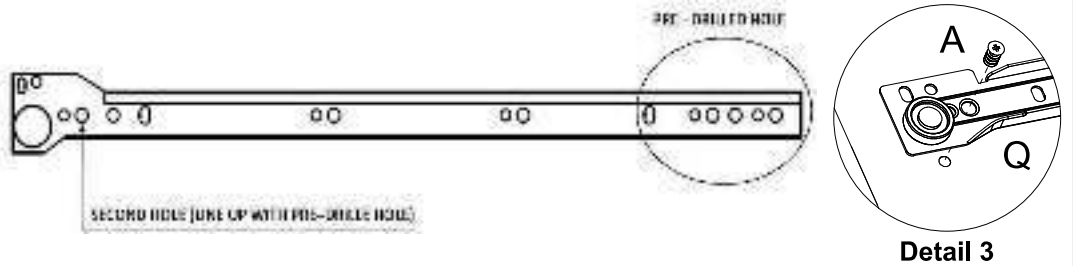
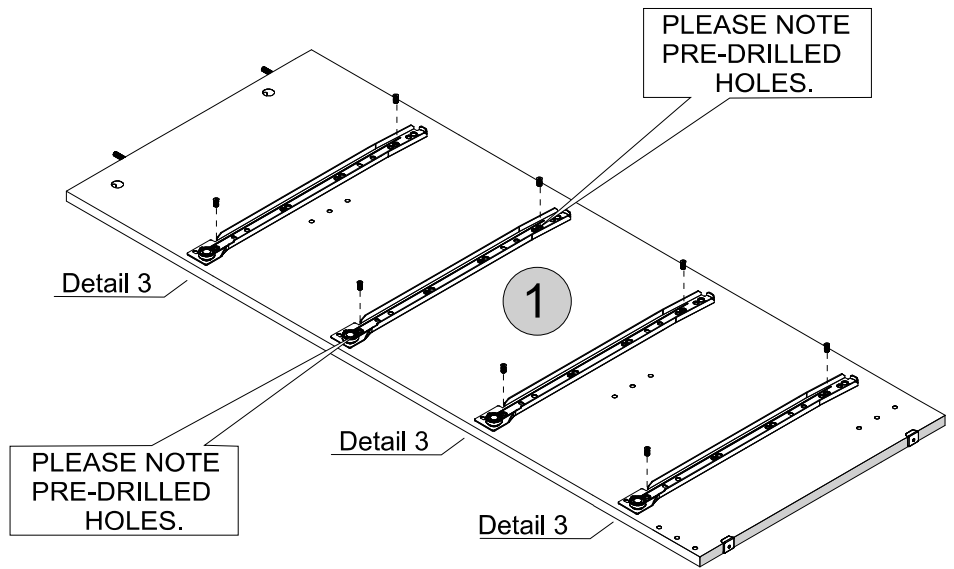
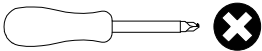

STEP 4

PARTS REQUIRED

2 - RIGHT SIDE PANEL x1

HARDWARE REQUIRED

A  08
Ø6 x 10

Q  04
RIGHT

TOOLS REQUIRED

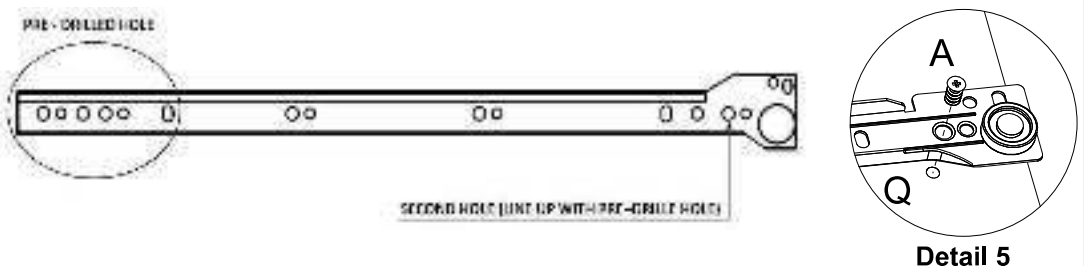
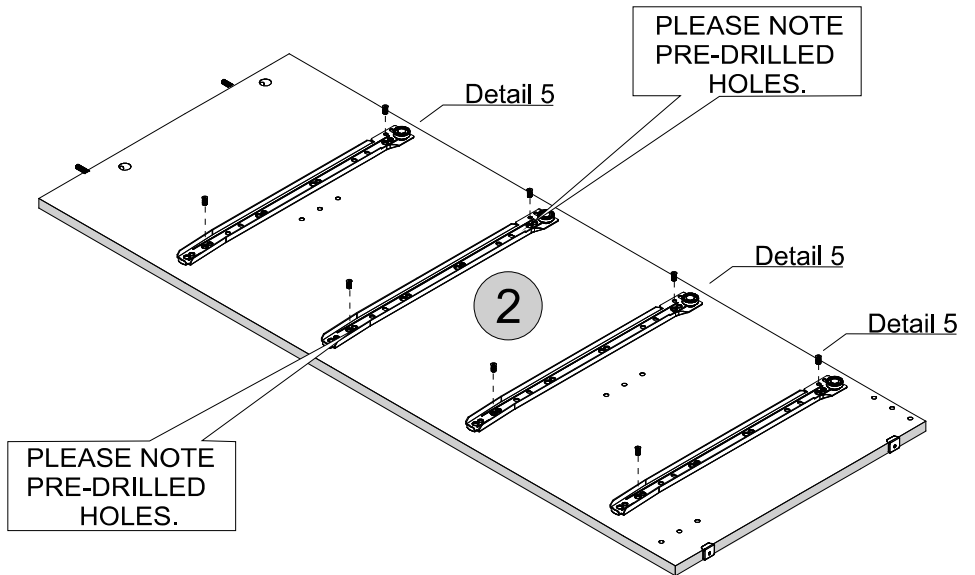
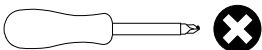

STEP 5

PARTS REQUIRED

4 - FRONT BASEBOARD x1

9 - BACK BASEBOARD x1

11 - CROSSBAR x2

HARDWARE REQUIRED

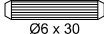
G  16
Ø6 x 30

H  02
10 x 10

L  02

P  01
GLUE

TOOLS REQUIRED

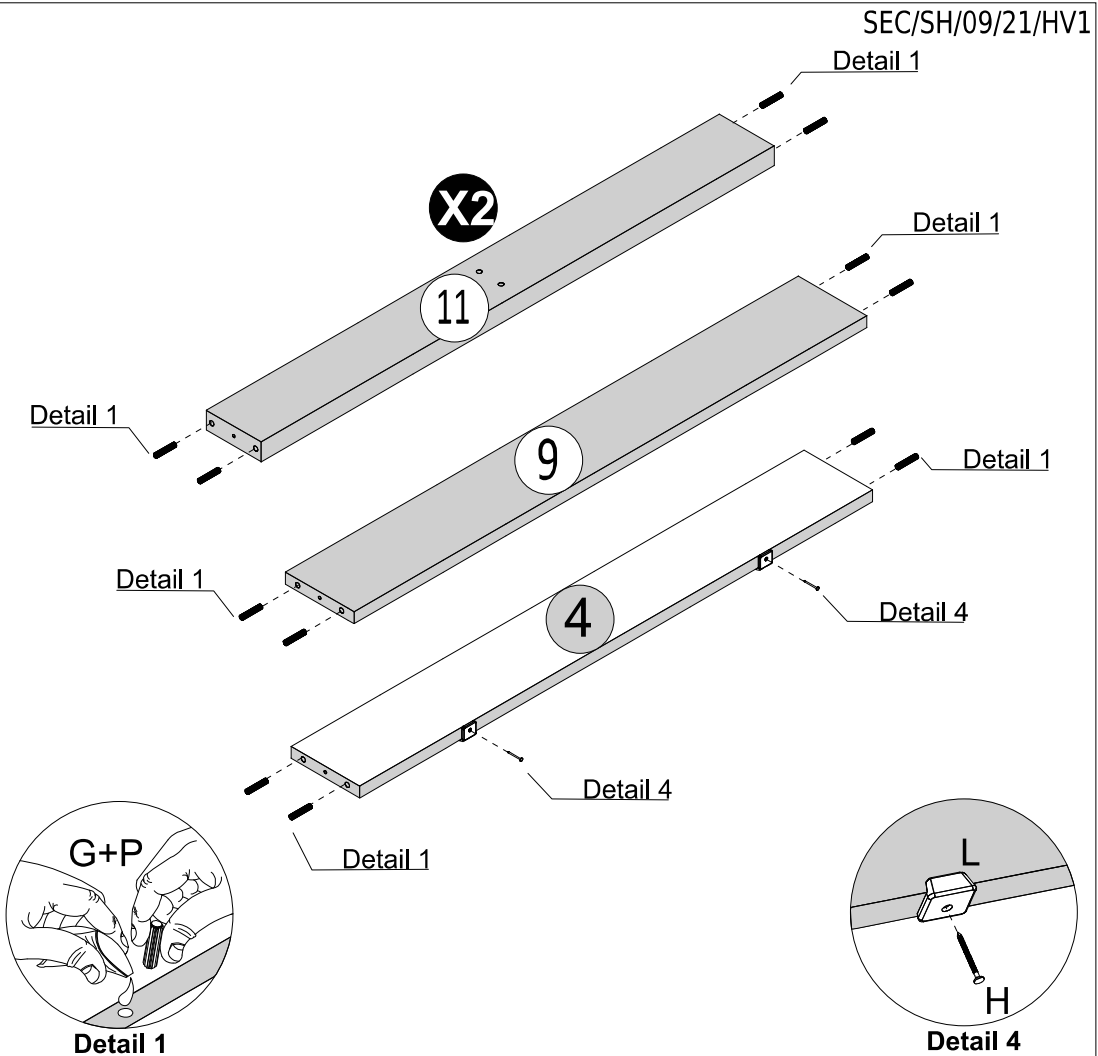
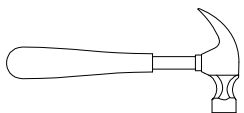



STEP 6

PARTS REQUIRED

12 - DIVISION PANEL x1

HARDWARE REQUIRED

B  02
Ø4.0 x 18mm

G  03
Ø6 x 30

P  01
GLUE

Q  01
LEFT

Q  01
RIGHT

TOOLS REQUIRED

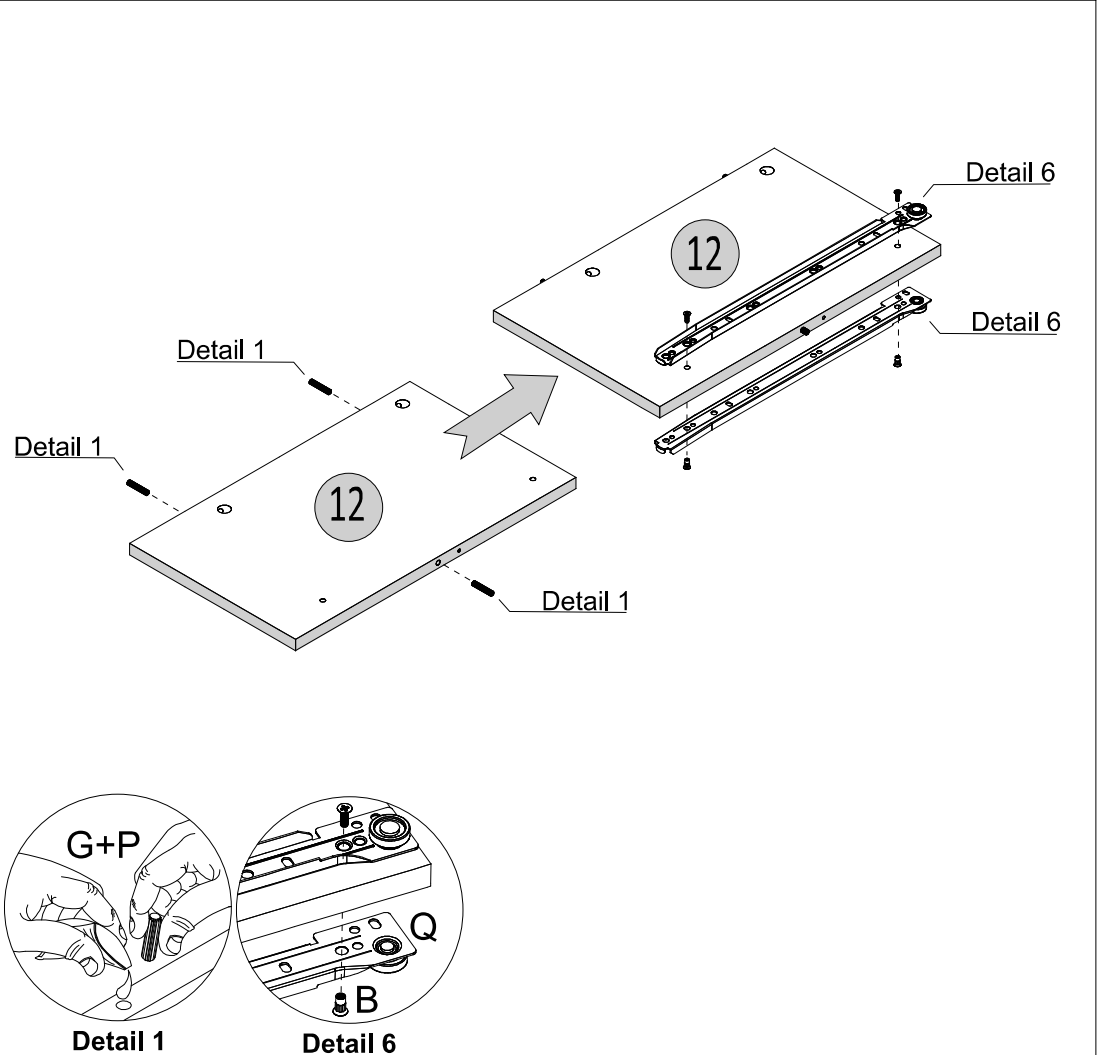
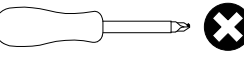



STEP 7

PARTS REQUIRED

- 2 - RIGHT SIDE PANEL x1
- 4 - FRONT BASEBOARD x1
- 9 - BACK BASEBOARD x1
- 11 - CROSSBAR x2

HARDWARE REQUIRED

- F  04
Ø4 x 50
- P  01

TOOLS REQUIRED

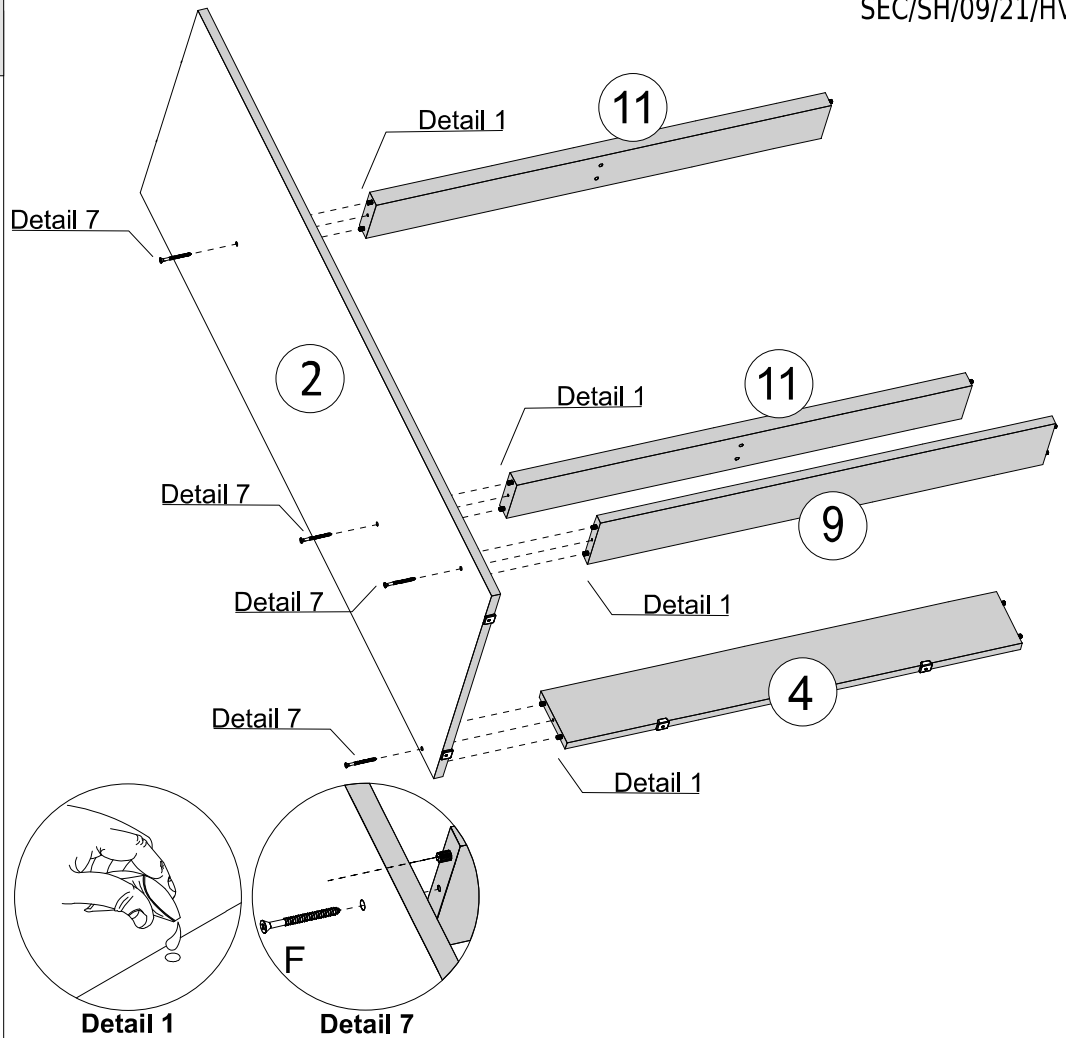
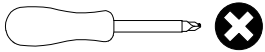

STEP 8

PARTS REQUIRED

- 1 - LEFT SIDE PANEL x1

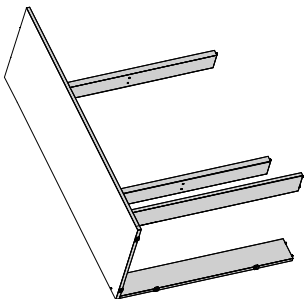

HARDWARE REQUIRED

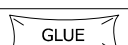
- F  04
Ø4 x 50
- P  01

TOOLS REQUIRED

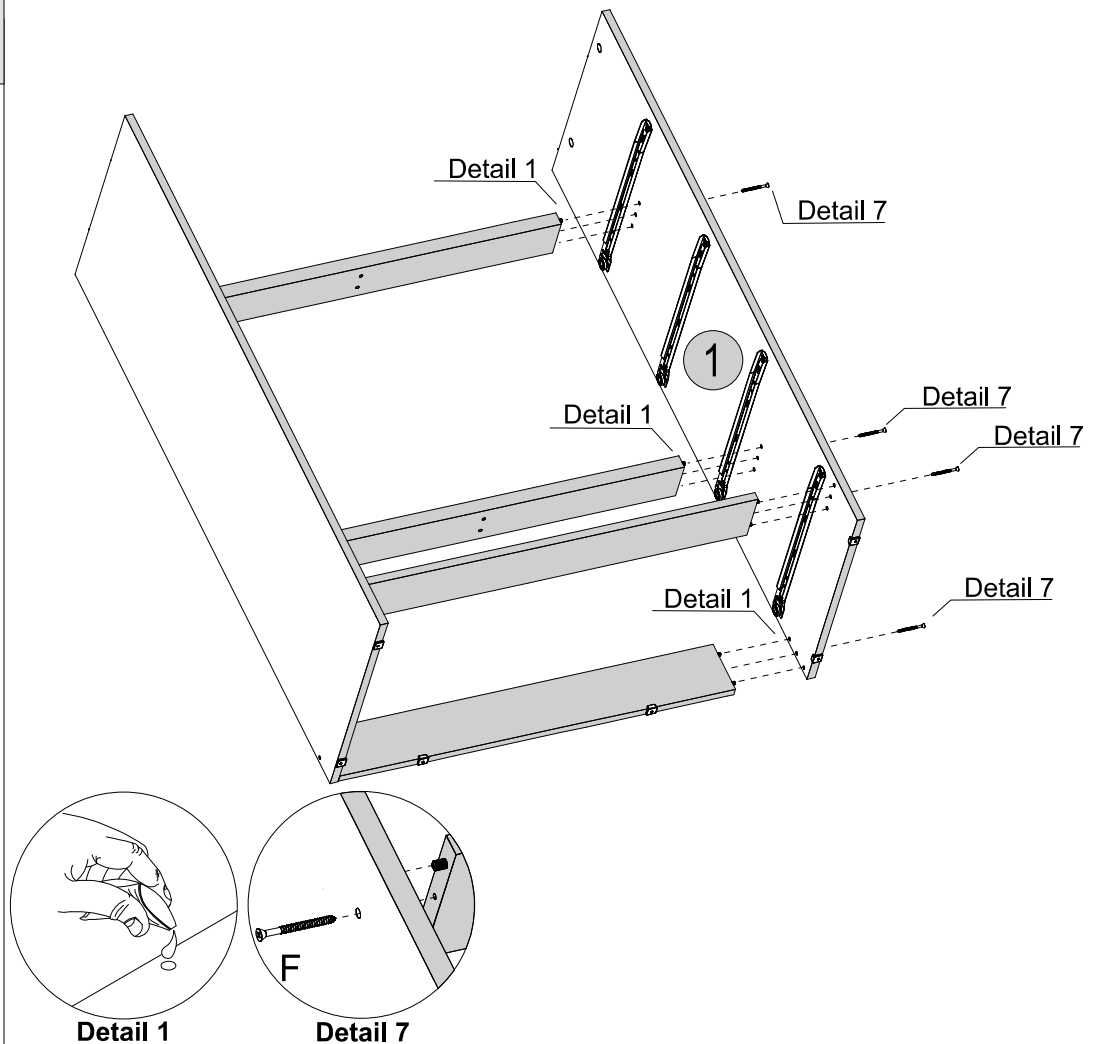
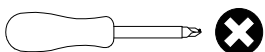

STEP 9

PARTS REQUIRED

3 - TOP PANEL x1

HARDWARE REQUIRED

N  06

TOOLS REQUIRED

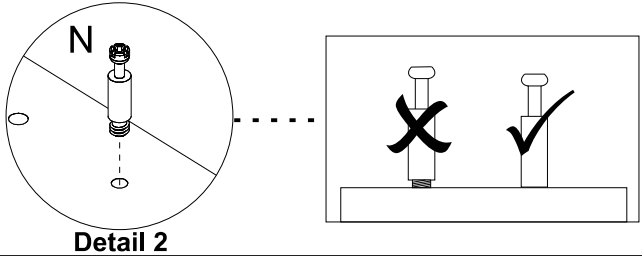
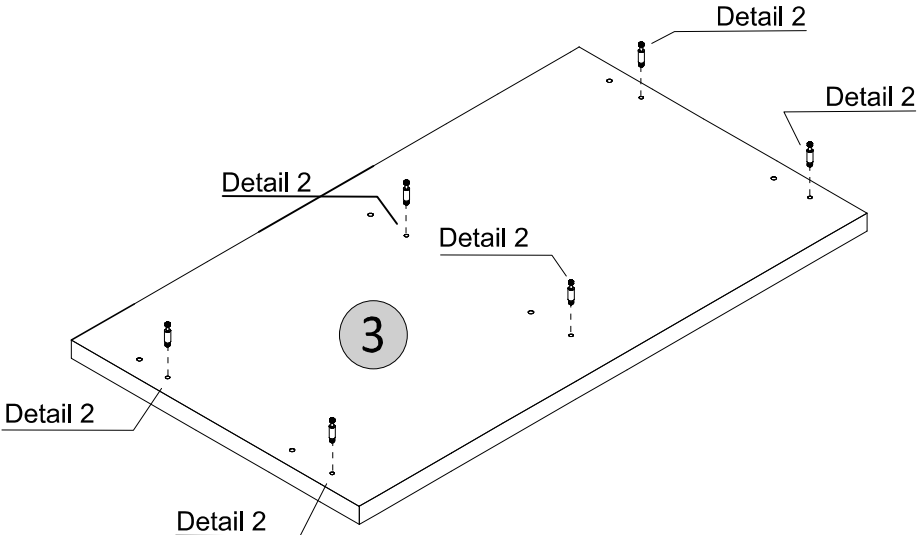
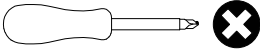

Detail 2

STEP 10

PARTS REQUIRED

3 - TOP PANEL x1

12 - DIVISION PANEL x1

HARDWARE REQUIRED

U  02

TOOLS REQUIRED

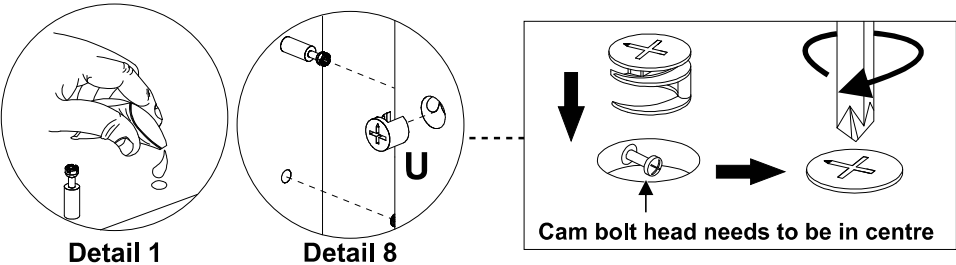
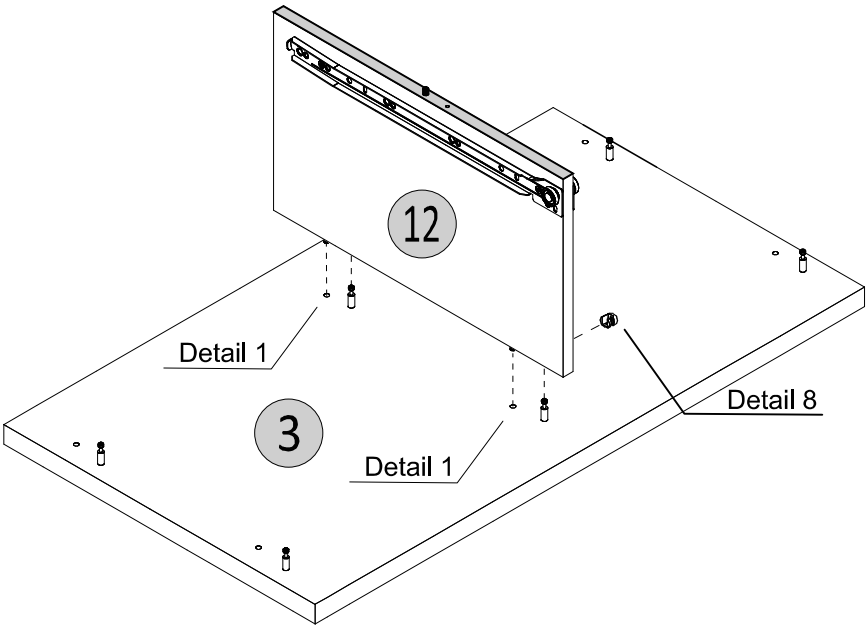
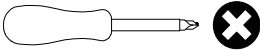

Detail 1

Detail 8



Cam bolt head needs to be in centre

STEP 11

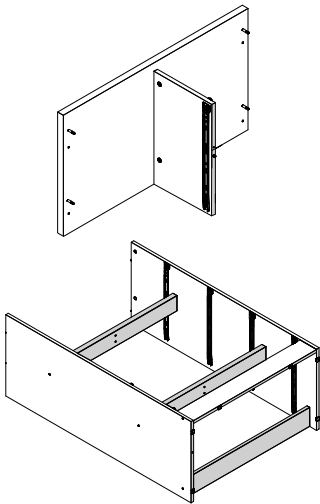
PARTS REQUIRED



HARDWARE REQUIRED

F		01
P		01
U		04

TOOLS REQUIRED

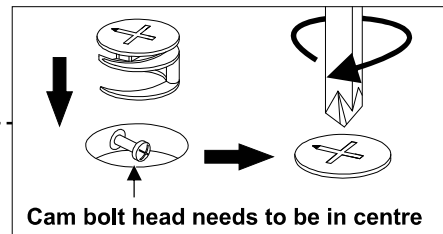
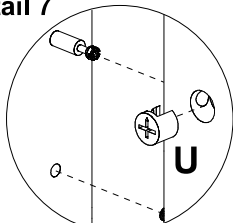
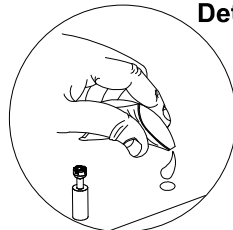
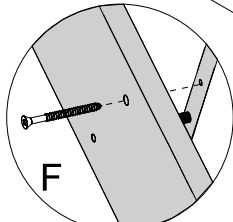
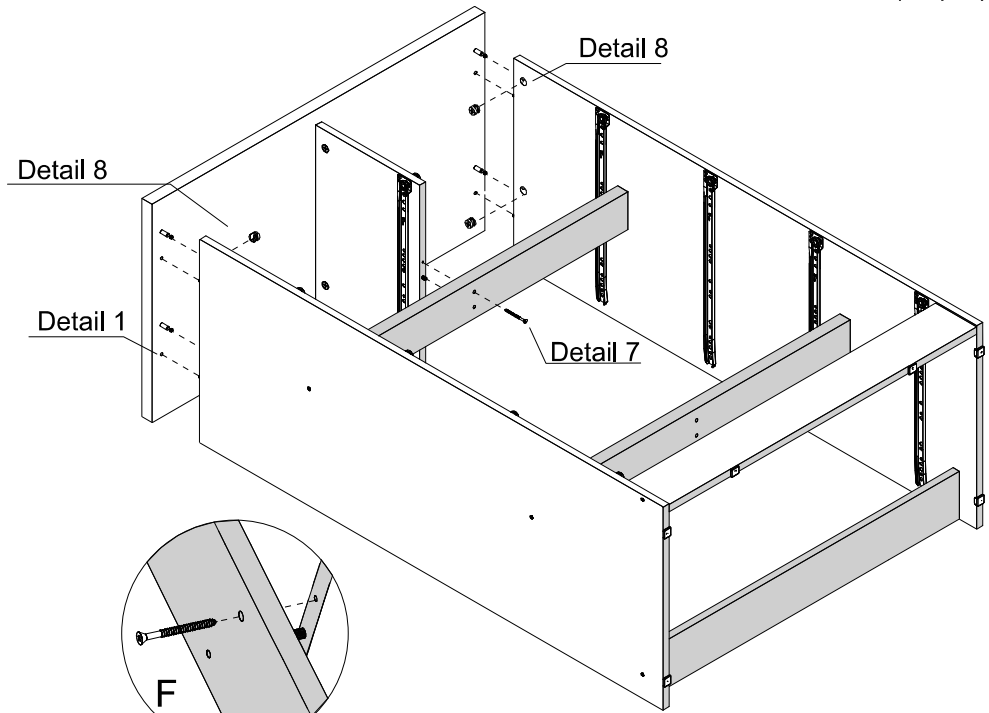
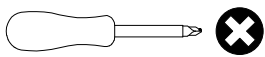



STEP 12

PARTS REQUIRED

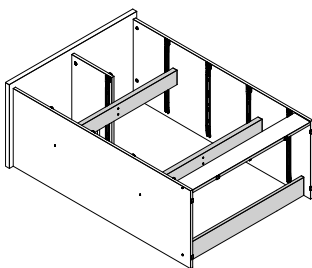
10 - BACK PANEL	x2
-----------------	----

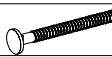

HARDWARE REQUIRED

H		32
I		02
R		01

TOOLS REQUIRED

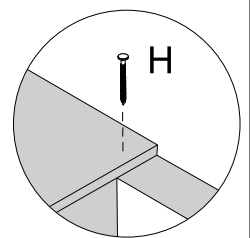
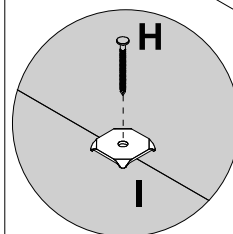
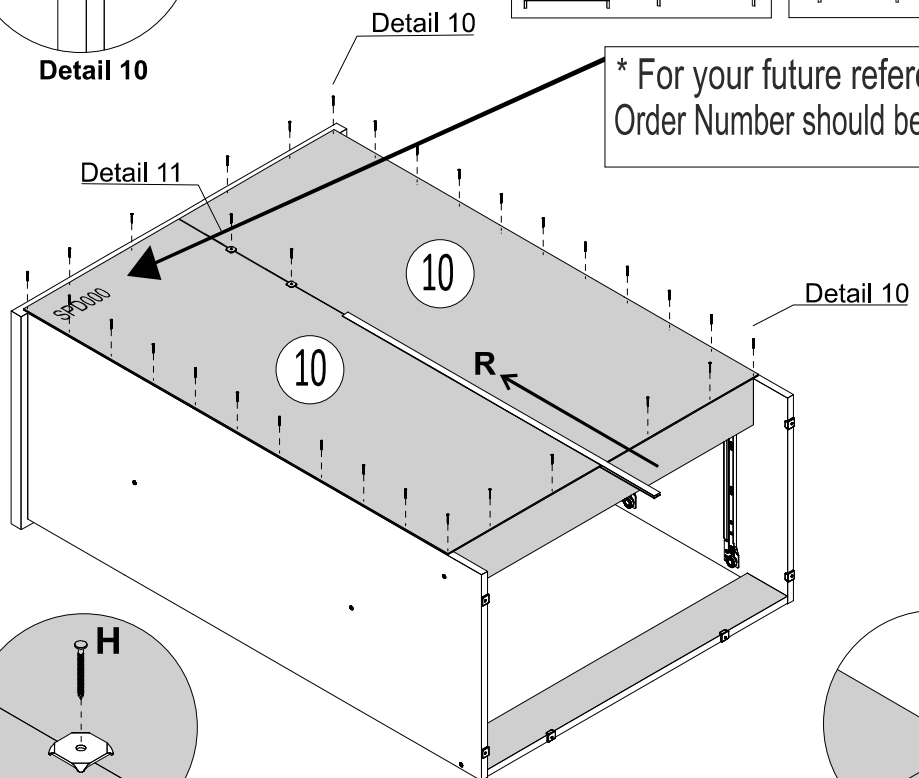
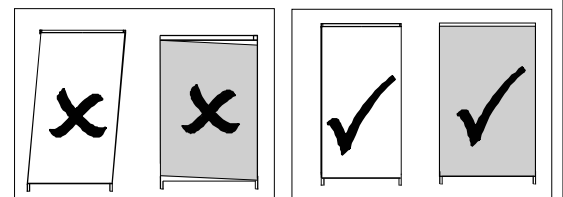
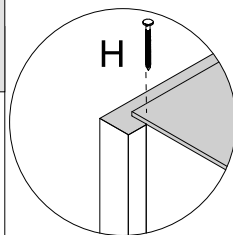
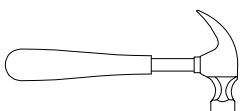



STEP 13

PARTS REQUIRED

- 6 - DRAWER SIDE x10
- 7 - SMALL DRAWER BACK PANEL x2
- 14 -LARGE DRAWER BACK PANEL x3
- 19 -DRAWER BOTTOM SUPPORT BAR x3

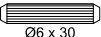
HARDWARE REQUIRED

- G  46
- P  01

TOOLS REQUIRED



Detail 1

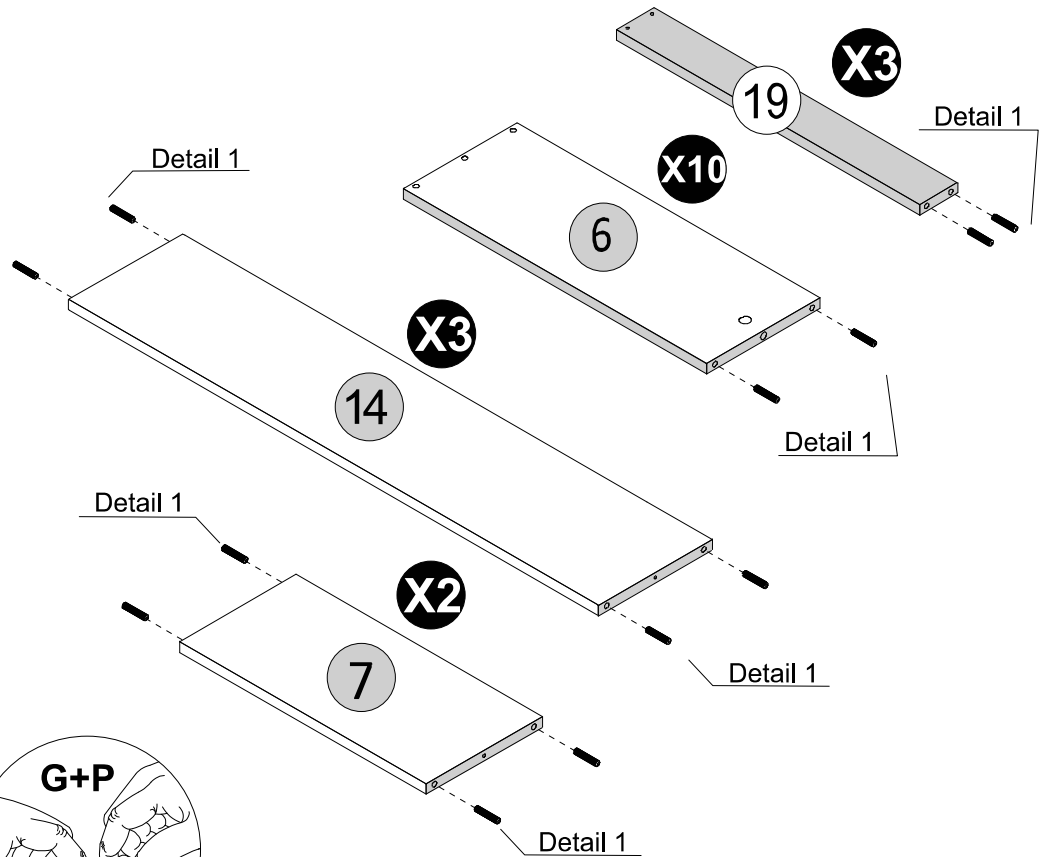

STEP 14

PARTS REQUIRED

- 13 -LARGE DRAWER FRONT x3
- 5 - SMALL DRAWER FRONT x2

HARDWARE REQUIRED

- N  10

TOOLS REQUIRED

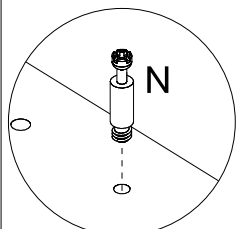
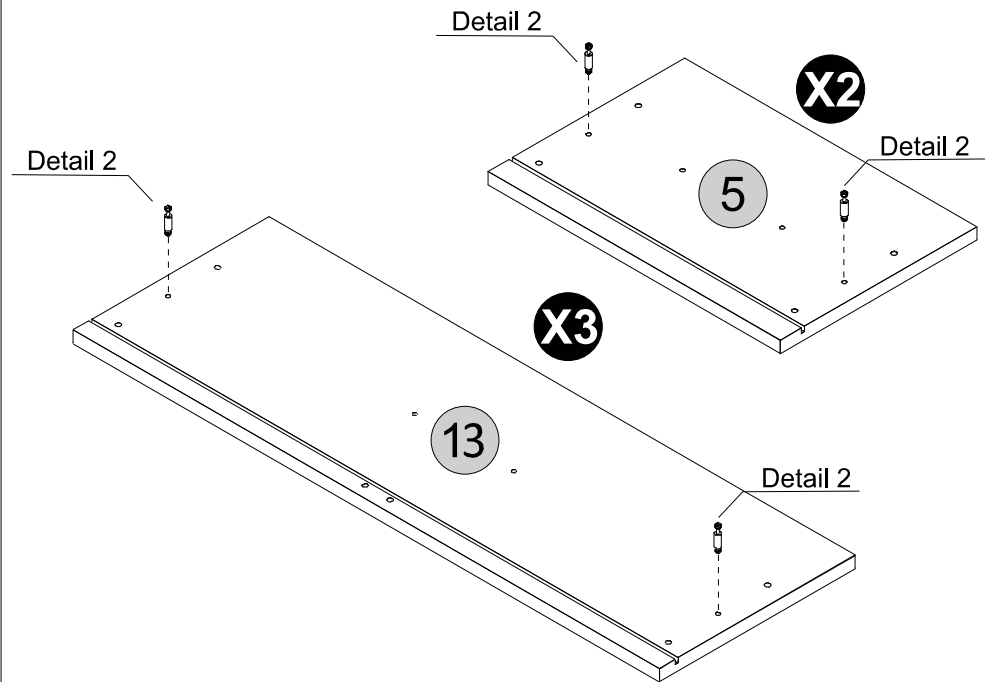
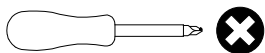

Detail 2

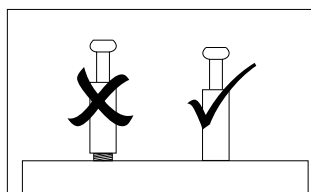

STEP 15

PARTS REQUIRED

6 - DRAWER SIDE x6

14 - LARGE DRAWER BACK PANEL x3

HARDWARE REQUIRED

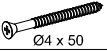
F  06
Ø4 x 50

TOOLS REQUIRED

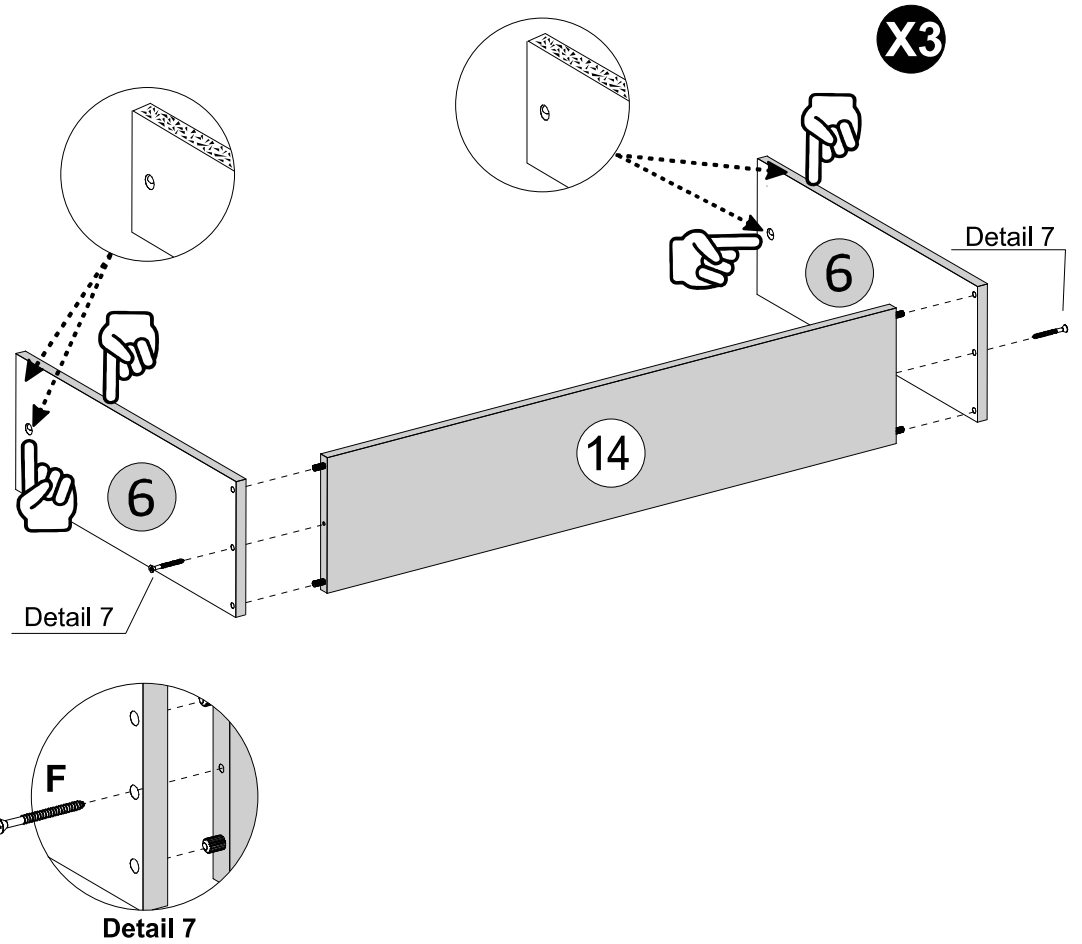
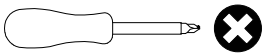

STEP 16

PARTS REQUIRED

13 - LARGE DRAWER FRONT x3

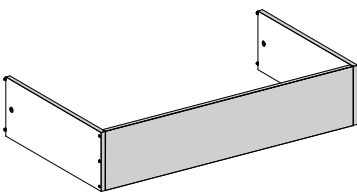

HARDWARE REQUIRED

J  06

P  01
GLUE

TOOLS REQUIRED

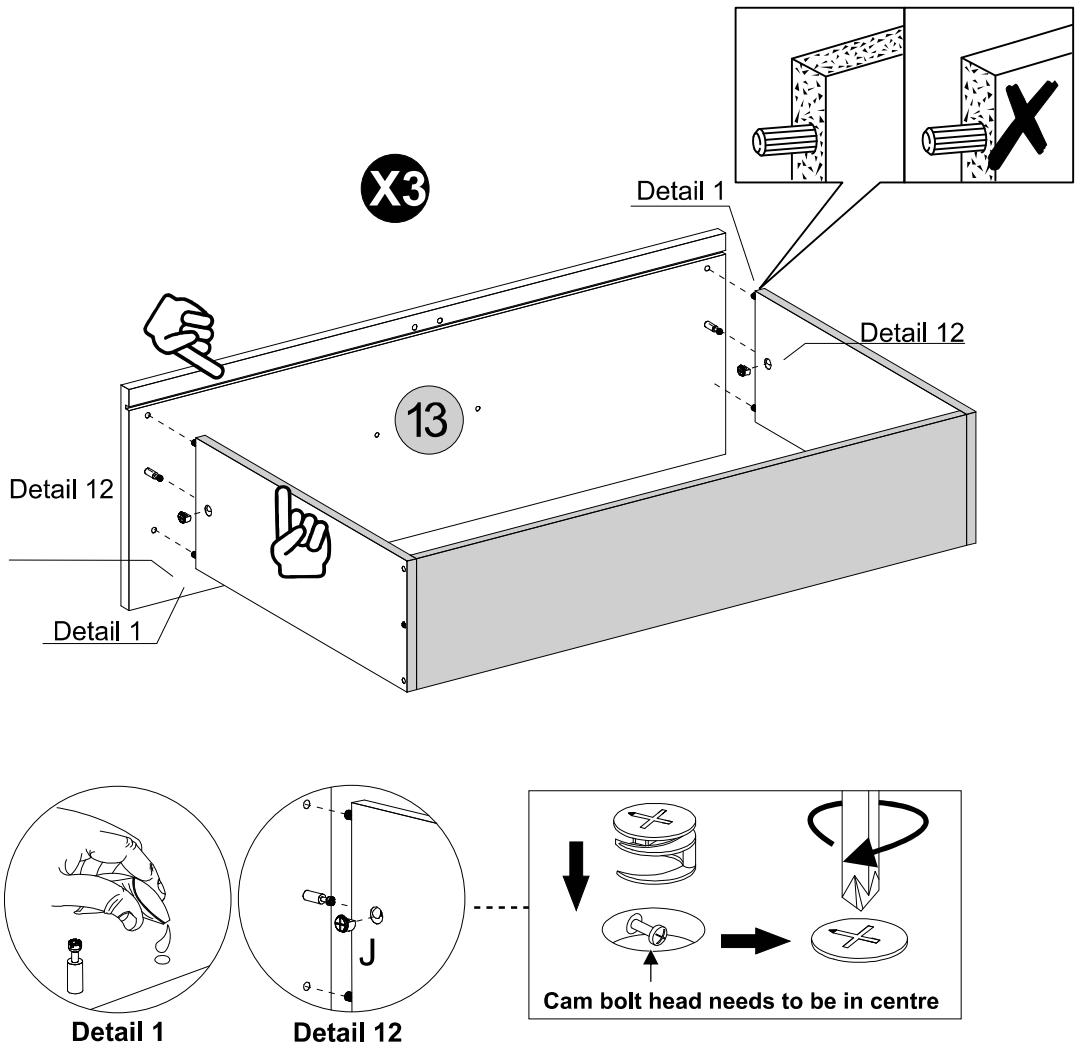
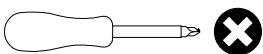

STEP 17

PARTS REQUIRED

18 -LARGE DRAWER BOTTOM x3

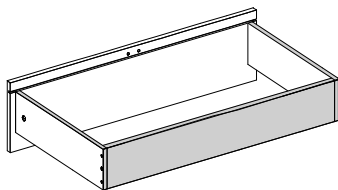

HARDWARE REQUIRED

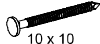
H  12

TOOLS REQUIRED

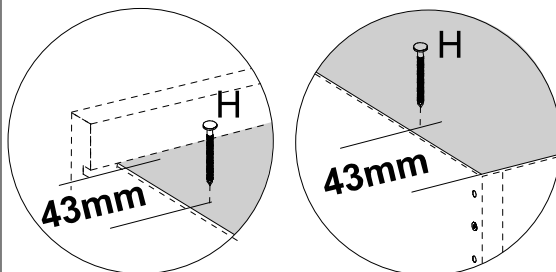
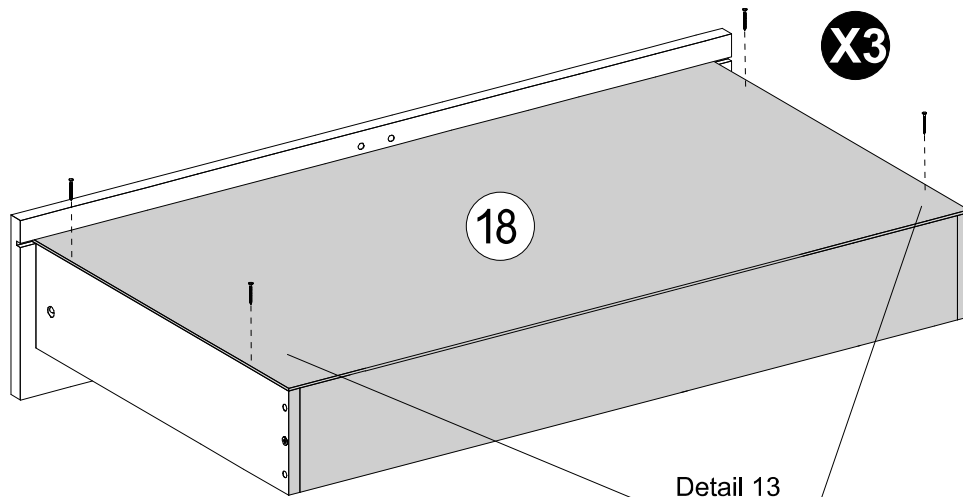
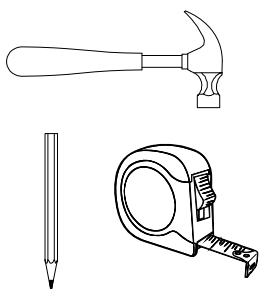

Detail 13

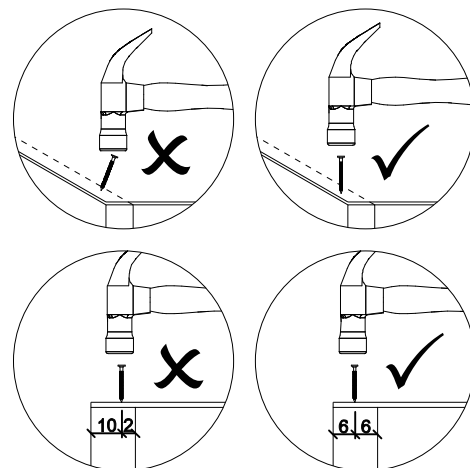

STEP 18

PARTS REQUIRED

19 -DRAWER BOTTOM SUPPORT BAR x3

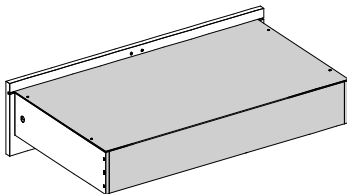

HARDWARE REQUIRED

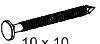
H  18

P  01

TOOLS REQUIRED

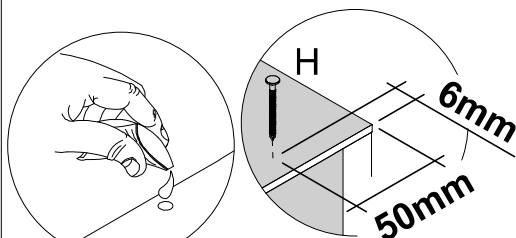
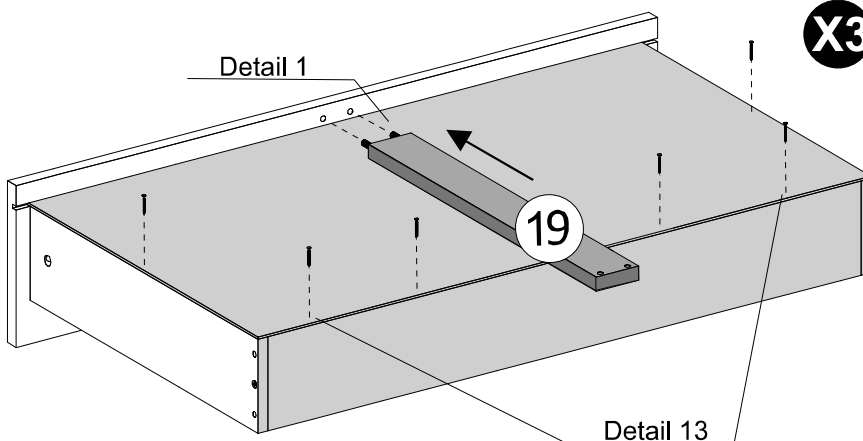
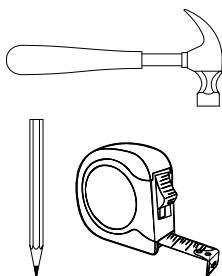

Detail 1

Detail 13

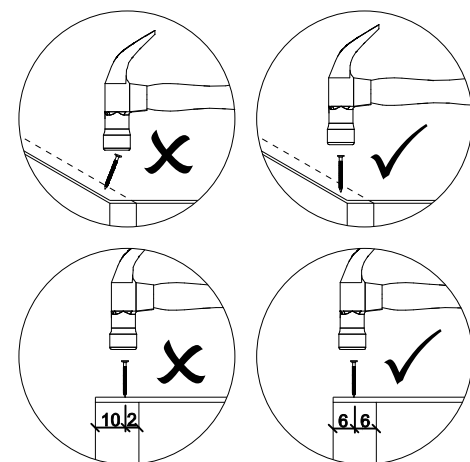

STEP 19

PARTS REQUIRED

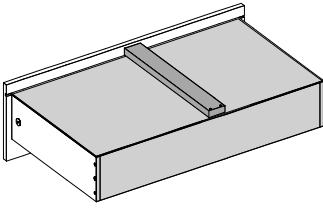

HARDWARE REQUIRED

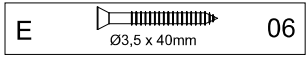
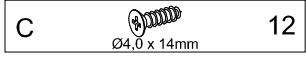

TOOLS REQUIRED

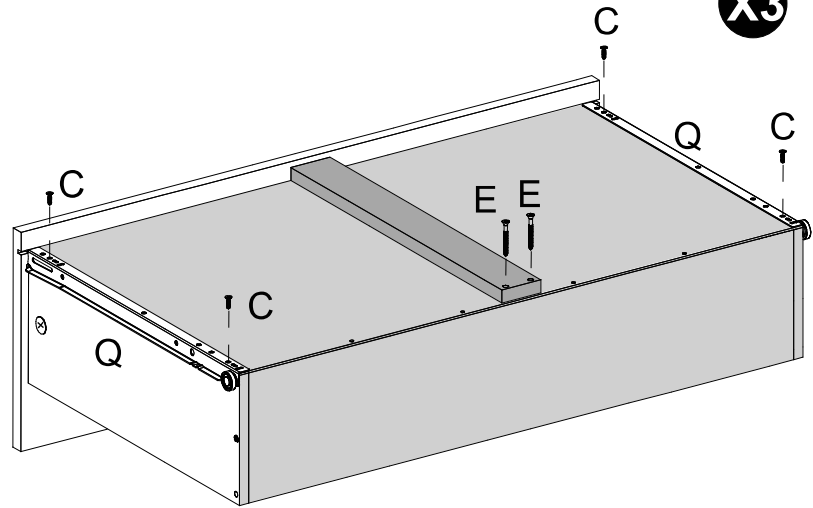
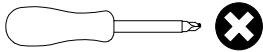

X3

STEP 20

PARTS REQUIRED

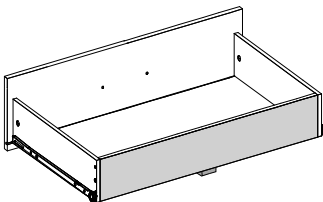

HARDWARE REQUIRED

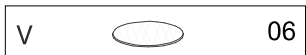
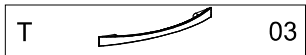
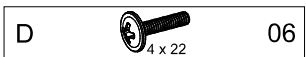

TOOLS REQUIRED

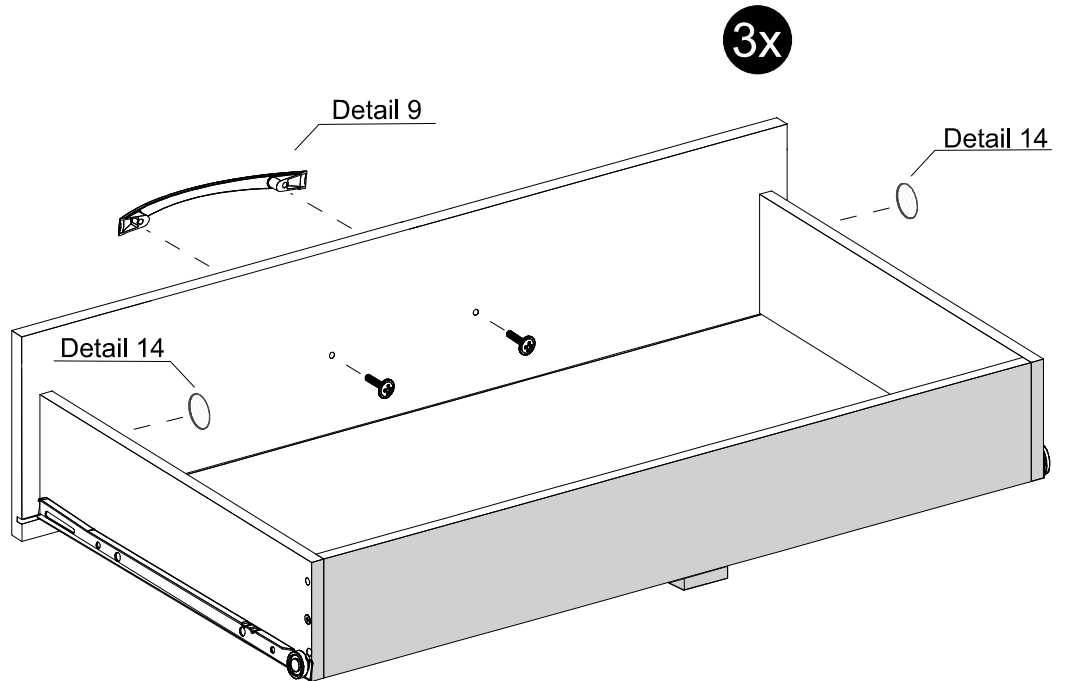
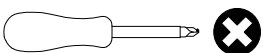

3x

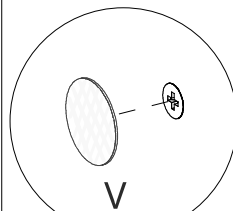

Detail 14

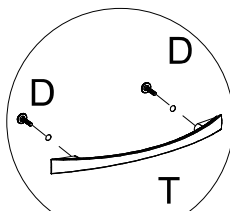

Detail 9

STEP 21

PARTS REQUIRED

6 - DRAWER SIDE x6

7 - DRAWER BACK PANEL x3

HARDWARE REQUIRED

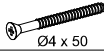
F  04
Ø4 x 50

TOOLS REQUIRED

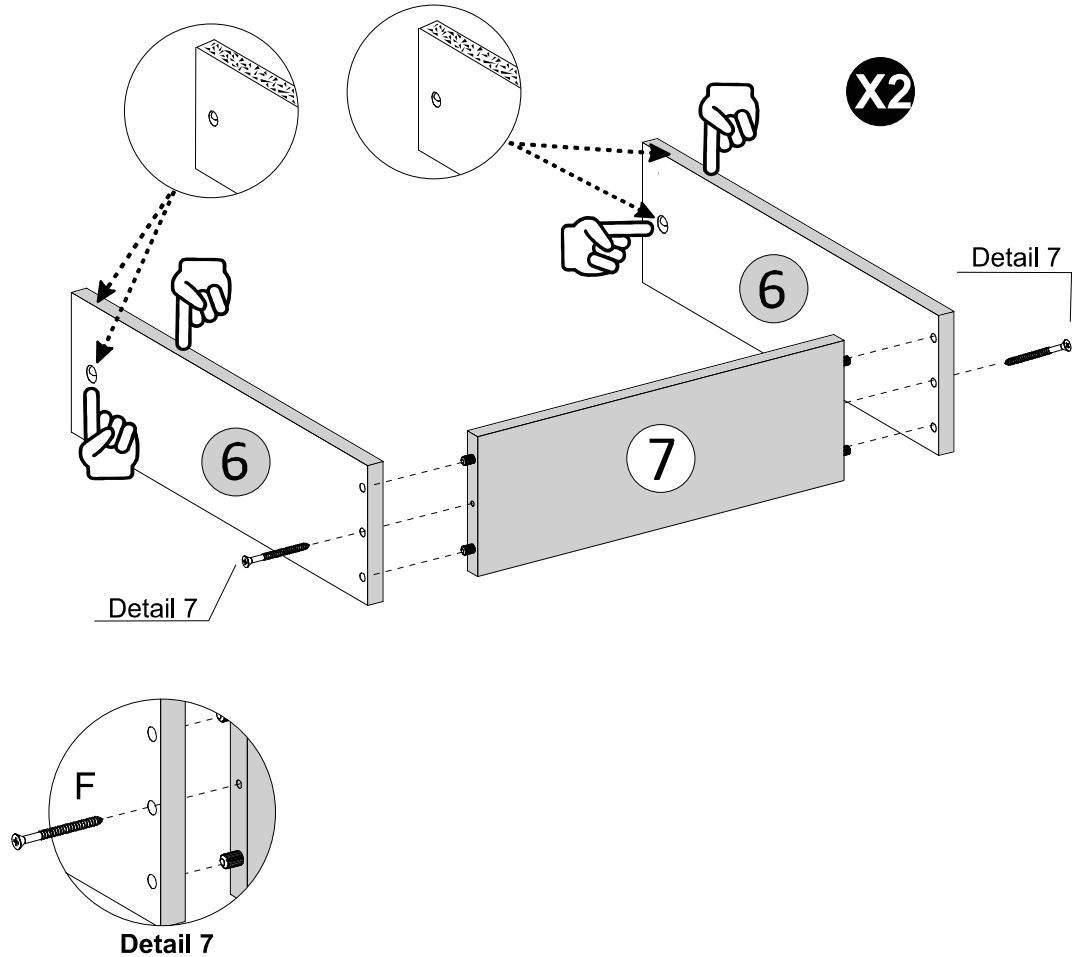
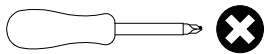

STEP 22

PARTS REQUIRED

5 - SMALL DRAWER FRONT x3

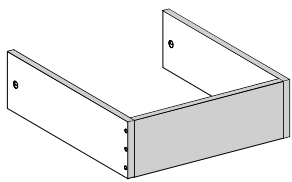

HARDWARE REQUIRED

J  04

P  01
GLUE

TOOLS REQUIRED

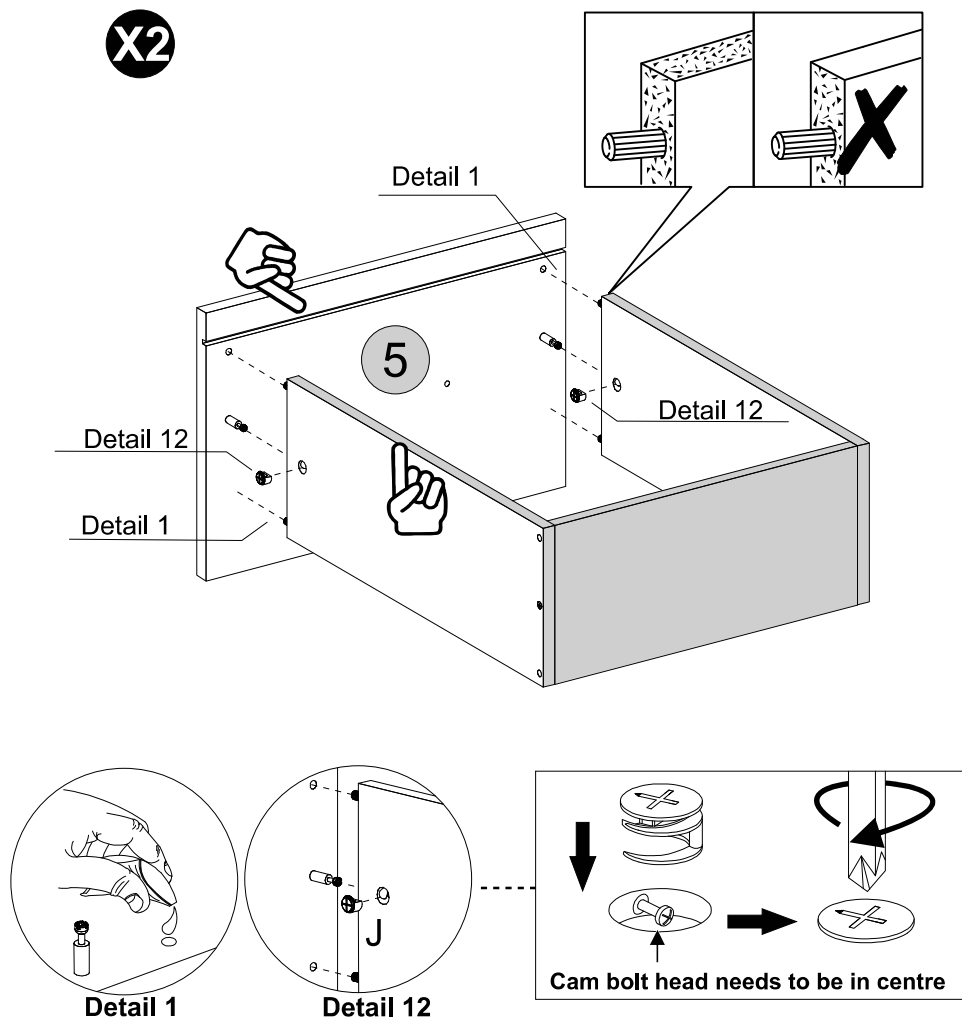
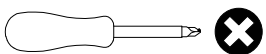

STEP 23

PARTS REQUIRED

8 - DRAWER BOTTOM x2

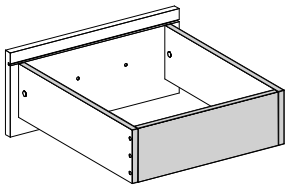

HARDWARE REQUIRED

H 10 x 10 08

TOOLS REQUIRED

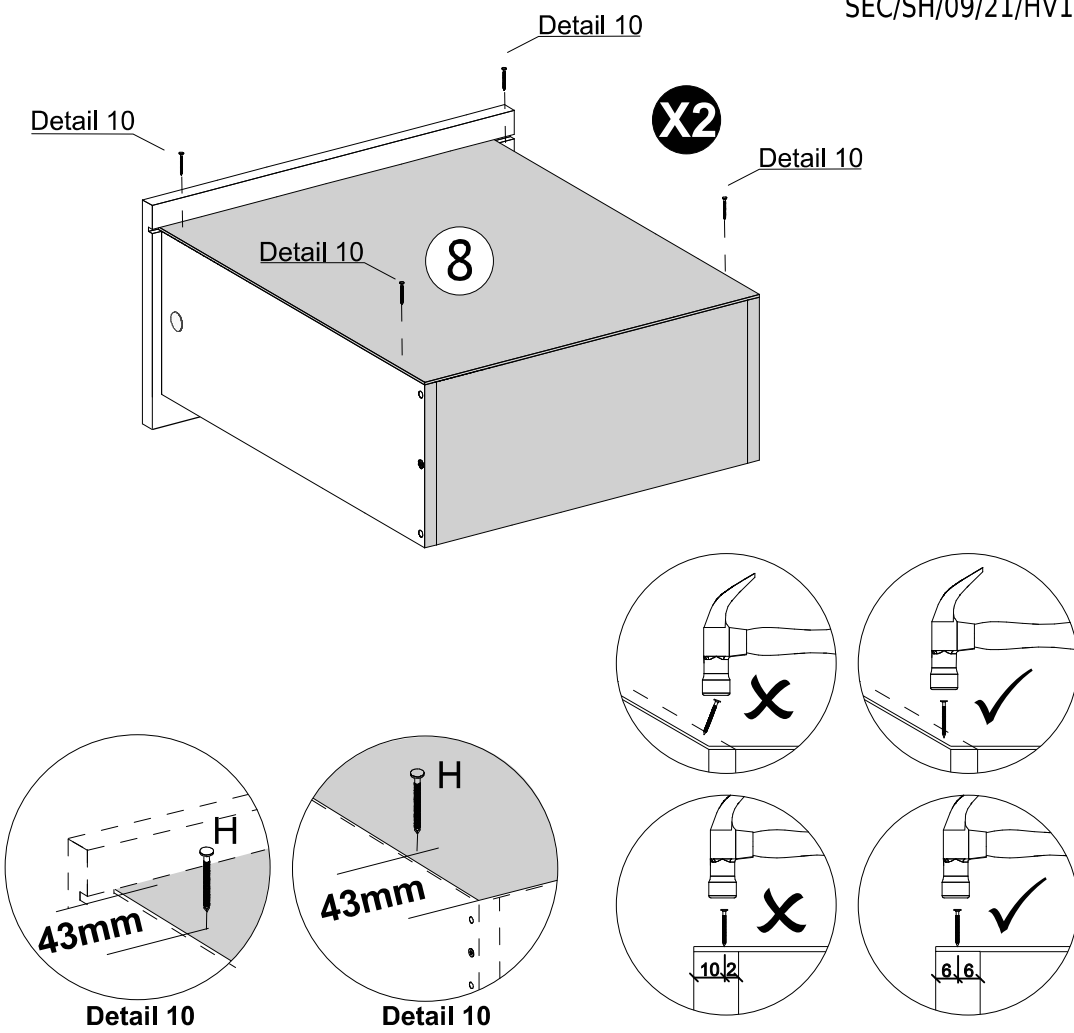
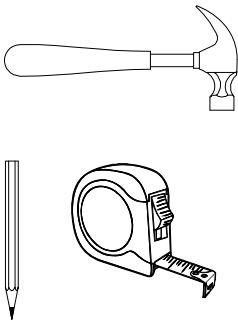

STEP 24

PARTS REQUIRED

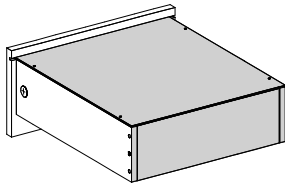

HARDWARE REQUIRED

H 10 x 10 08

TOOLS REQUIRED

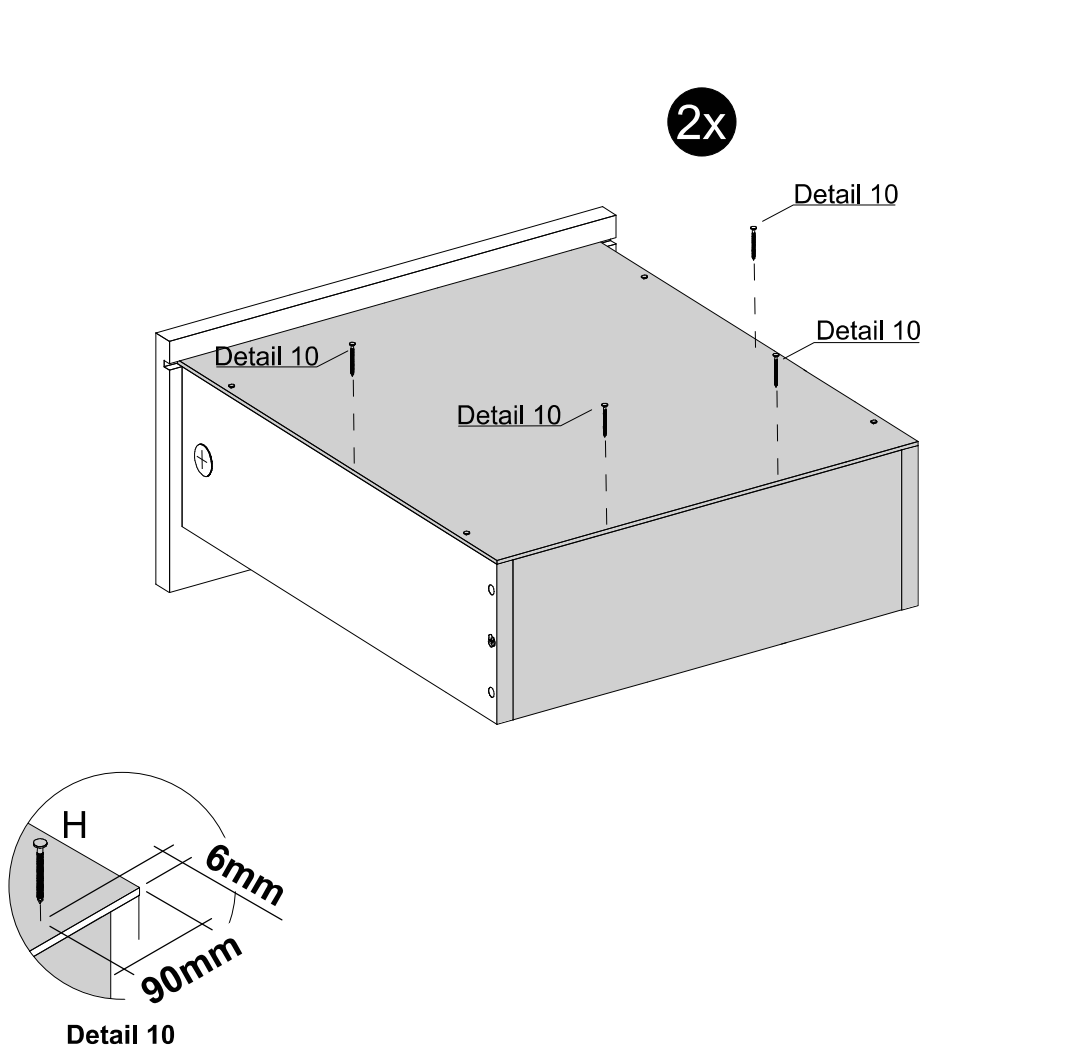
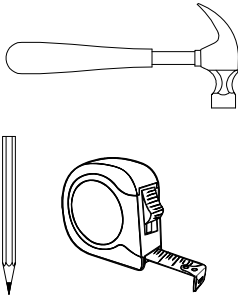

STEP 25

PARTS REQUIRED

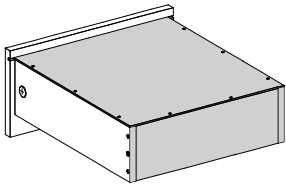

HARDWARE REQUIRED

C	 Ø4.0 x 14mm	08
---	---	----

Q	LEFT	02
---	------	----

Q	RIGHT	02
---	-------	----

TOOLS REQUIRED

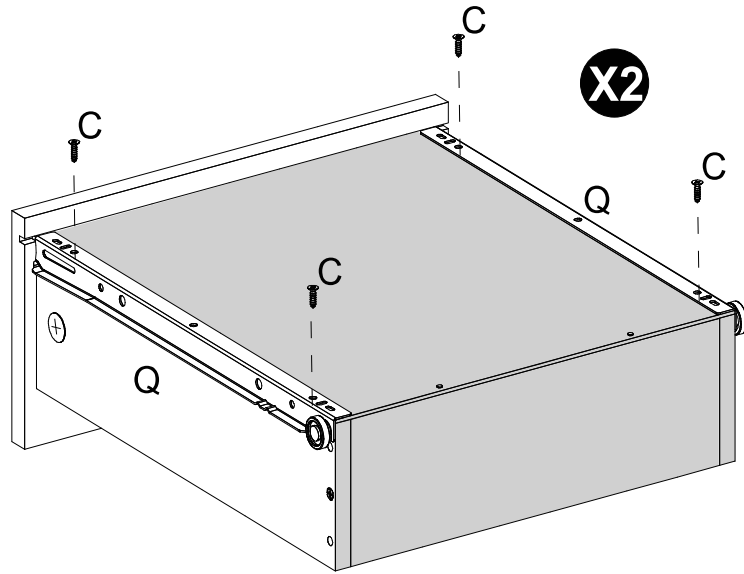
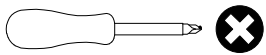

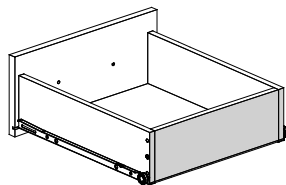

STEP 26

PARTS REQUIRED



HARDWARE REQUIRED

D	 4 x 22	04
---	--	----

V		04
---	---	----

T		02
---	---	----

TOOLS REQUIRED

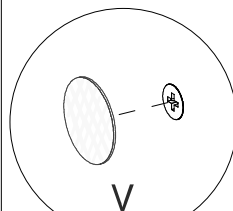
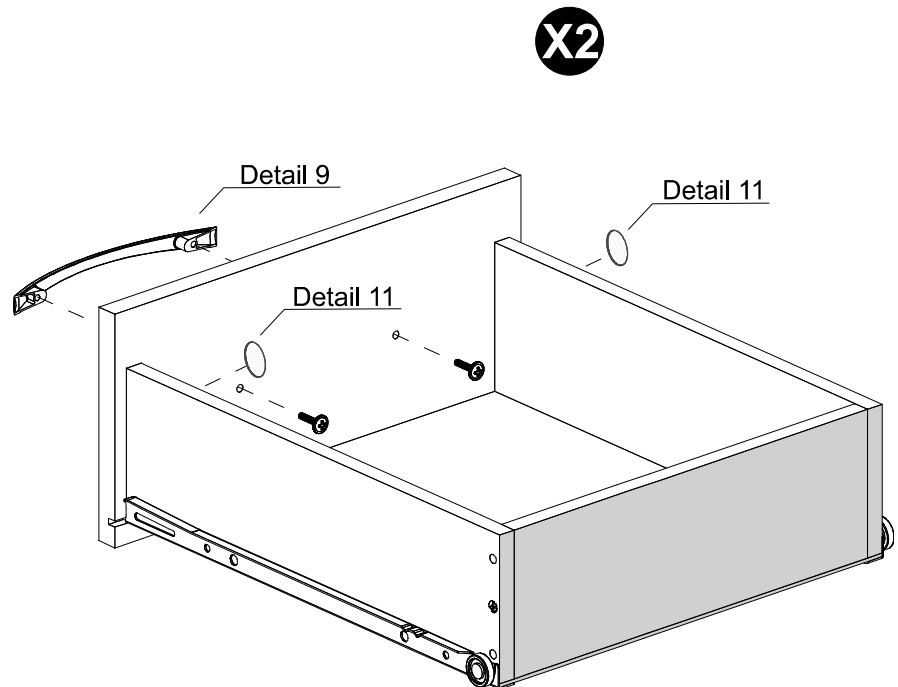
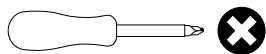

Detail 11

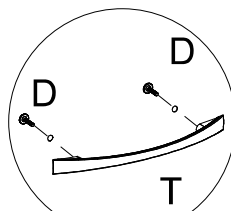

Detail 9

STEP 27

PARTS REQUIRED

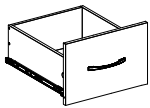
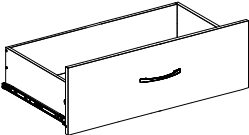
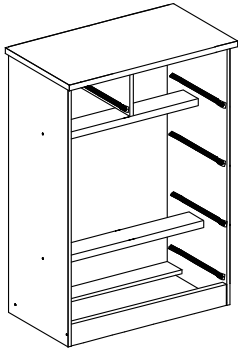

HARDWARE REQUIRED

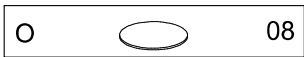

TOOLS REQUIRED

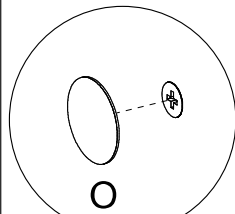
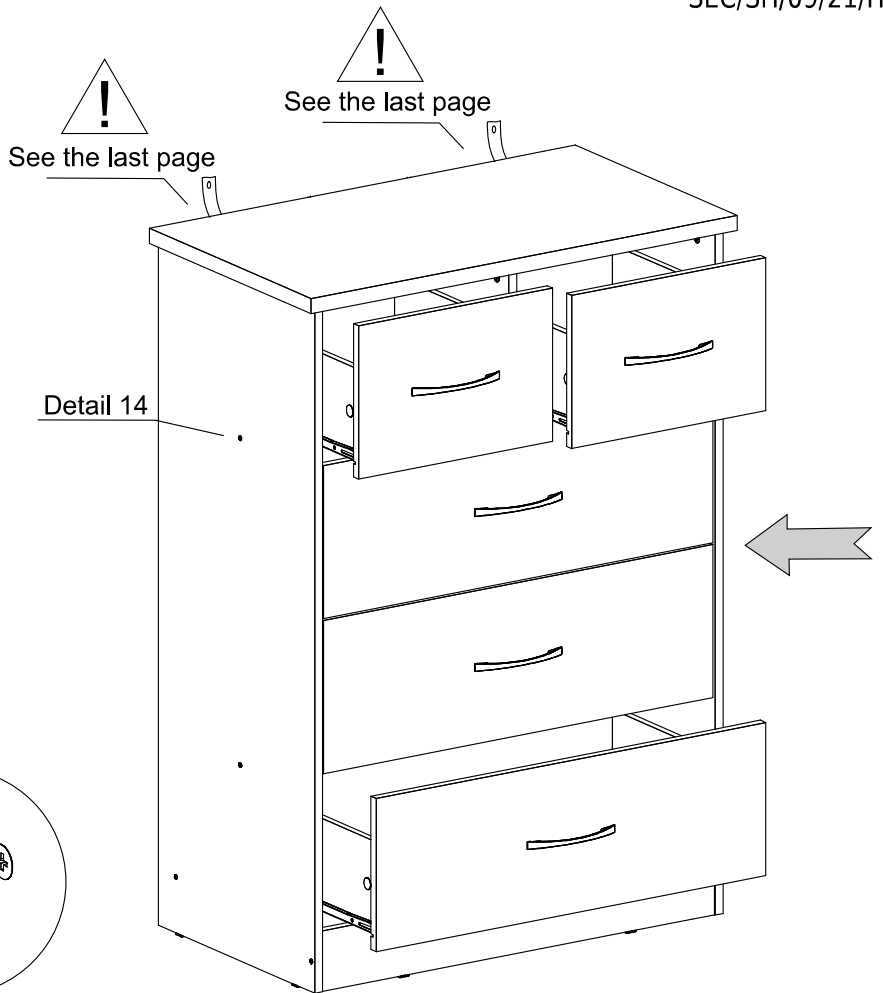

Detail 14

STEP 28

PARTS REQUIRED

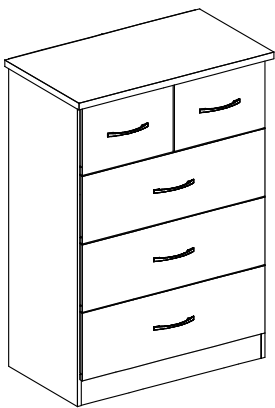

HARDWARE REQUIRED

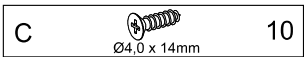

TOOLS REQUIRED

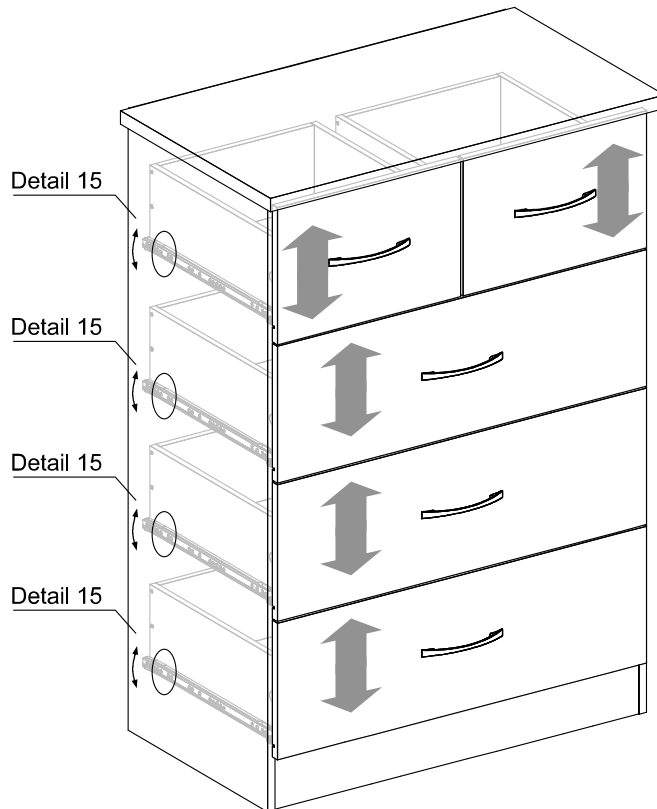

TIP
If desired, after assembly use an alcohol cleaner to erase the number printed on the parts.

Drawer Adjustment

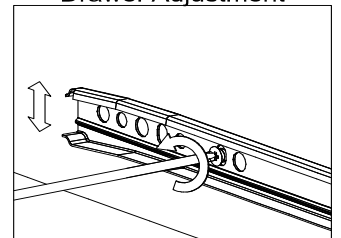

Right Side

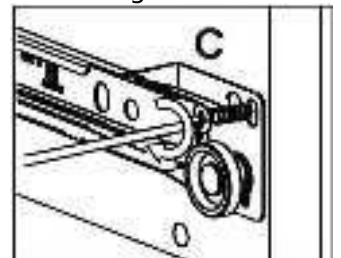

Left Side

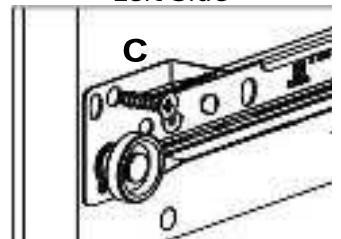

Detail 15

WARNING

Serious or fatal injuries can occur from furniture tipping over. To prevent the furniture from tipping over we recommend that it is permanently fixed to the wall.

Wall fixings are not supplied with this product as different wall materials require different types of fixing devices. Please make sure you use fixings suitable for the walls in your home.

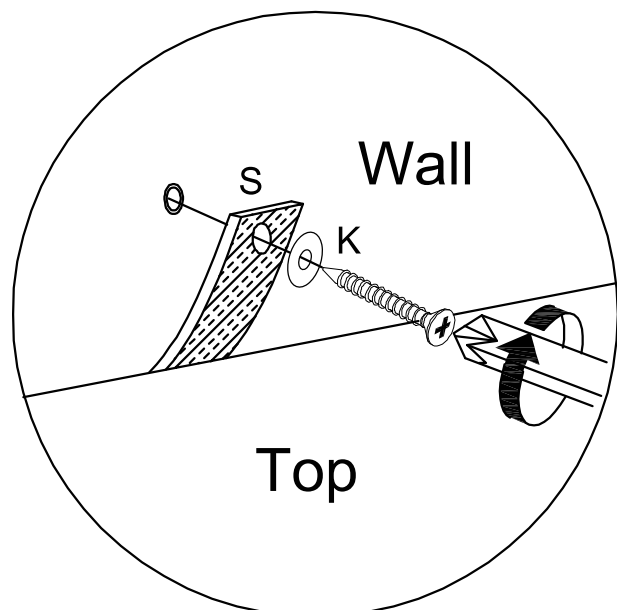
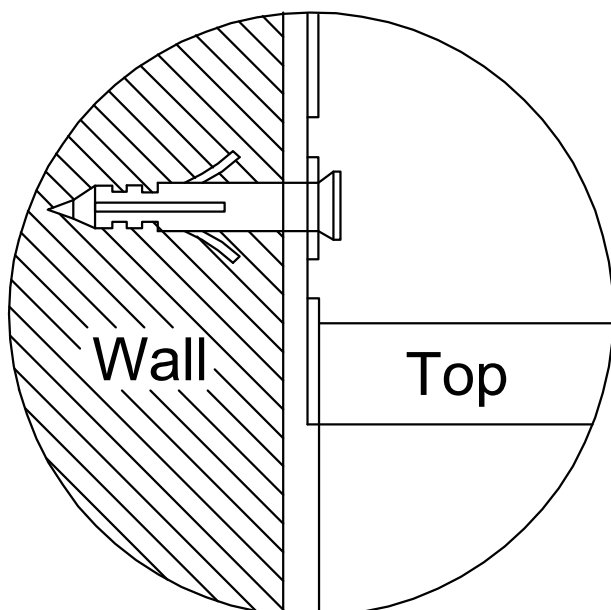
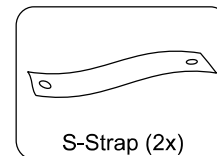
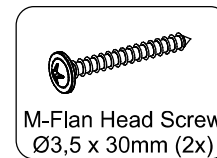
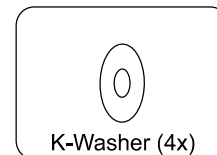
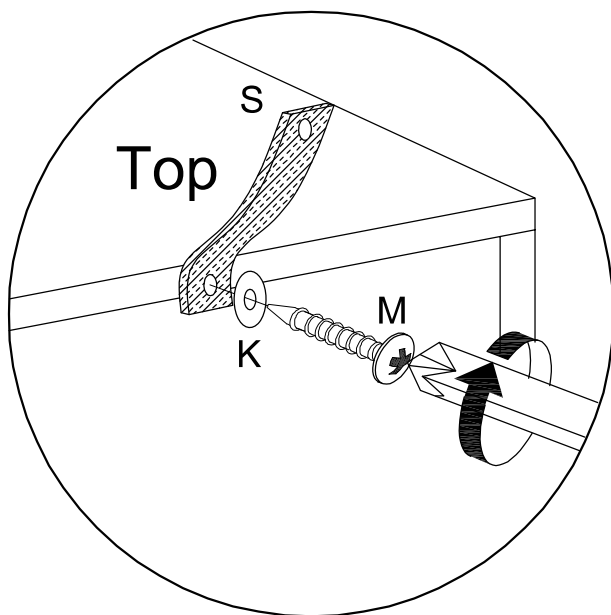

NEVADA 3 DRAWER BEDSIDE ASSEMBLY INSTRUCTIONS

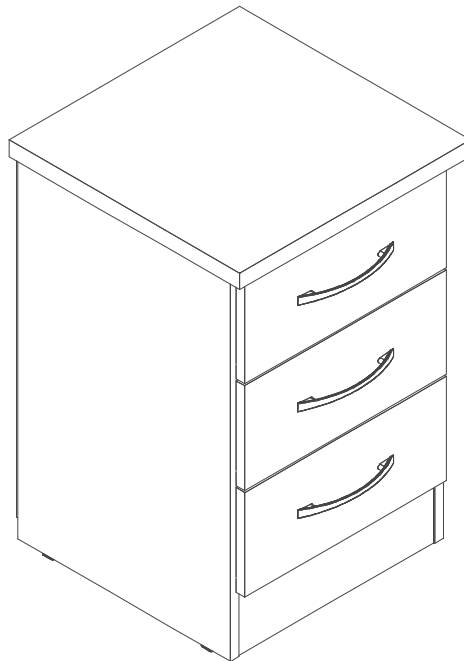

IMPORTANT FOR DOMESTIC USE ONLY

PLEASE READ BEFORE YOU CONTINUE FURTHER

CARE AND MAINTENANCE

After unpacking this product please keep the original packaging in case it needs to be returned for any reason.

- Please ensure all fittings and parts are present before commencing with assembly.
- Never drag or push products as this could cause damage to the joints making it inferior.
- We strongly recommend that you keep children away from your work area.
- We recommend that you lay a blanket or sheet on the floor to avoid damage to both your floor and the product.
- Assemble this product as close to its final position as possible.
- Do not place this product next to a radiator or in direct sunlight.
- Do not drag or push items across your high gloss furniture as this may cause the surface to scratch
- Wood is a natural product and may expand if subjected to damp and may shrink or crack if subjected to heat. Therefore it is recommended that room temperature is maintained, with no sudden temperature fluctuations.
- Make sure any spillage is wiped off immediately.
- Do not place hot or chilled items directly on to the surface, use a place mat or marking will occur.
- For general cleaning use a soft cotton or micro fibre cloth, and do not use detergents of any kind.
- From time to time it may be necessary to tighten fittings, regular inspections should be carried out.
- Do not place on a wet or damp floor as staining may occur to your floor.

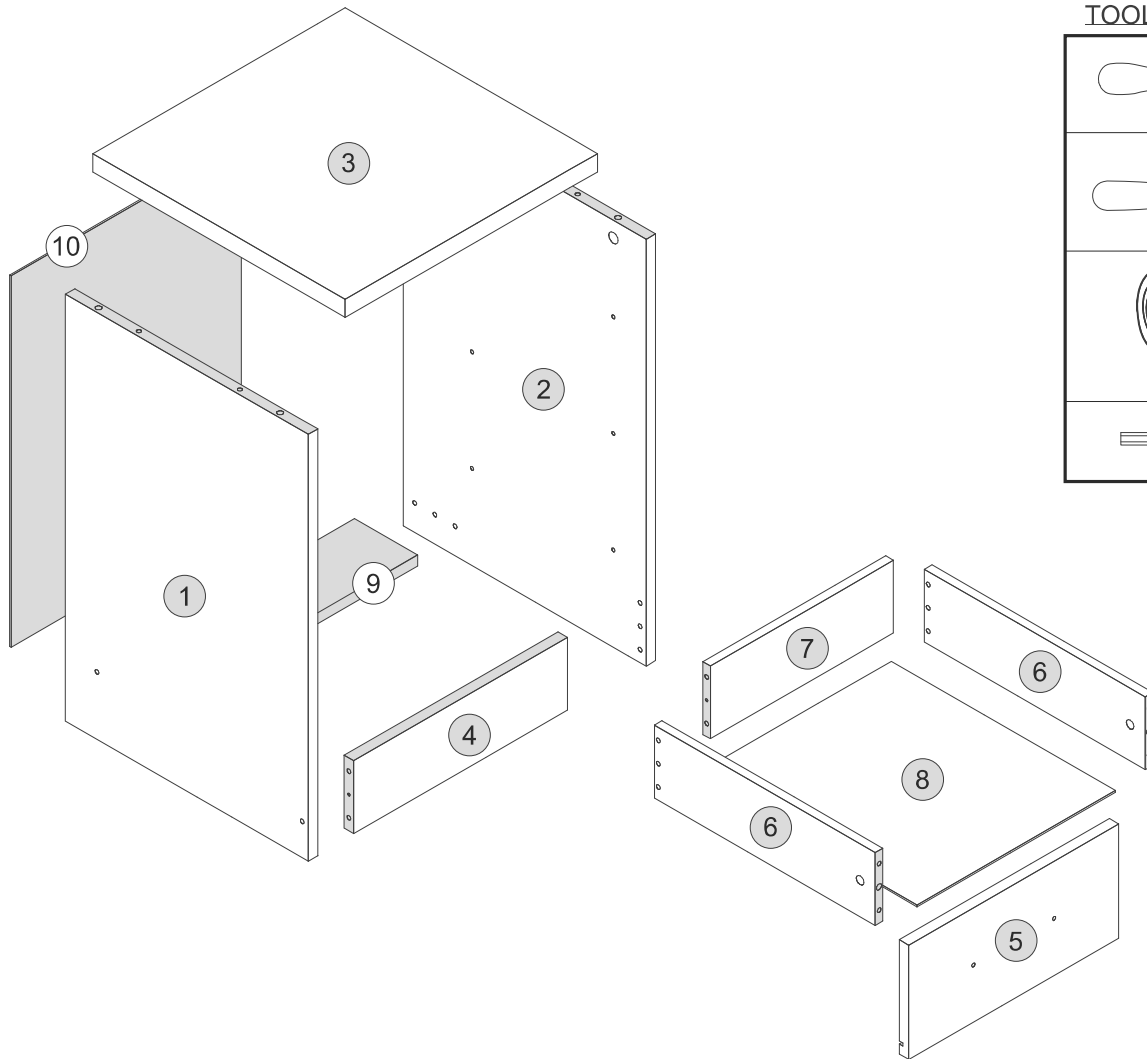

TOOLS REQUIRED

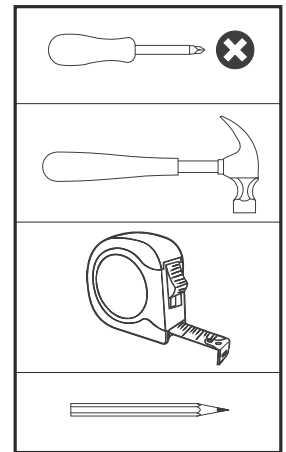









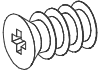
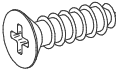
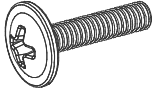

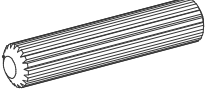

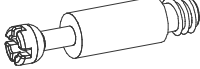
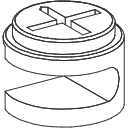
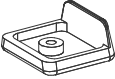
PARTS LIST

Please Note:
The below parts have all been stamped with the part number to help identify them during assembly.

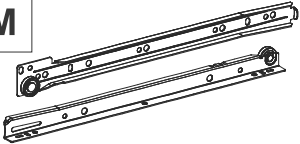
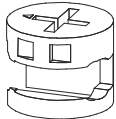
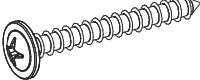
Part Number	Part Description	Quantity	Carton
01	Left Side Panel	1	1/1
02	Right Side Panel	1	1/1
03	Top Panel	1	1/1
04	Front Baseboard	1	1/1
05	Drawer Front	3	1/1
06	Drawer Side	6	1/1
07	Drawer Back Panel	3	1/1
08	Drawer Bottom	3	1/1
09	Back Baseboard	1	1/1
10	Back Panel	1	1/1

FITTINGS LIST

<p>A</p>  <p>Flat Head Screw 2/+ Ø6,0 x 10mm (12x)</p>	<p>B</p>  <p>Flat Head Screw 2/+ Ø4,0 x 14mm (18x)</p>	<p>C</p>  <p>Flan Head Screw Ø4,0 x 20mm (6x)</p>	<p>D</p>  <p>Flat Head Screw 1/+ Ø4,0 x 50mm (10x)</p>
<p>E</p>  <p>2/+ Dowel Ø6,0 x 30mm (36x)</p>	<p>F</p>  <p>2/+ Nail 10x10 Ringed-1,5x23mm (42x)</p>	<p>G</p>  <p>2/+ Cam Bolt (10x)</p>	<p>H</p>  <p>1/+ Cam Nut Ø12x8 8mm (6x)</p>
<p>I</p>  <p>1/+ Plastic Foot L 19x17x8mm Ø2 (4x)</p>	<p>J</p>  <p>2/+ Hole Plugs 19mm (4x)</p>	<p>K</p>  <p>Glue 10 Gr (2x)</p>	<p>L</p>  <p>Handle (3x)</p>
<p>M</p>  <p>Drawer Runners 350mm (3x)</p>	<p>N</p>  <p>1/+ Cam Nut Ø14,9x11 mm (4x)</p>	<p>O</p>  <p>1/+ Flan Head Screw Ø3,5 x 30mm (1x)</p>	<p>P</p>  <p>Strap 200x20x1MM (1x)</p>
<p>Q</p>  <p>1/+ Washer Ø16x7 (2x)</p>	<p>R</p>  <p>+1/2 Hole Plugs Lineo 19mm (6 x)</p>		

TIPS FOR FITTINGS CAM-LOCKS

WHEN FITTING CAM NUT. ENSURE STARTING POSITION IS CORRECT BEFORE YOU INSERT CONNECTING CAM BOLT TURN CLOCKWISE UNTIL SECURE



✓



↑

CORRECT



✗



↑

WRONG

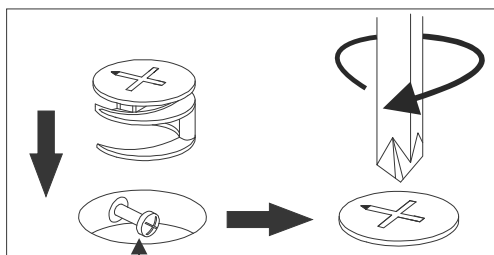

Cam bolt head needs to be in centre

CAMBOLT

Tighten until shoulder is flush with panel. Do not overtighten or undertighten (see example below)

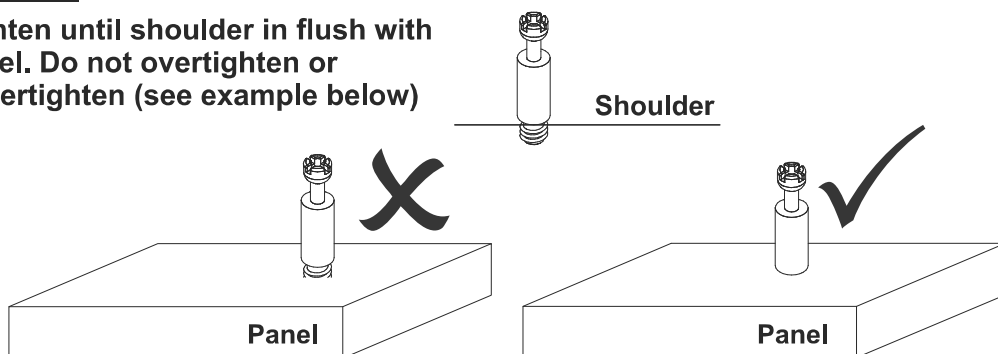



STEP 1

PARTS REQUIRED

1 - LEFT SIDE PANEL x1

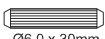
HARDWARE REQUIRED

E  02
Ø6,0 x 30mm

F  02
10 x 10

I  02

K  01
GLUE

TOOLS REQUIRED

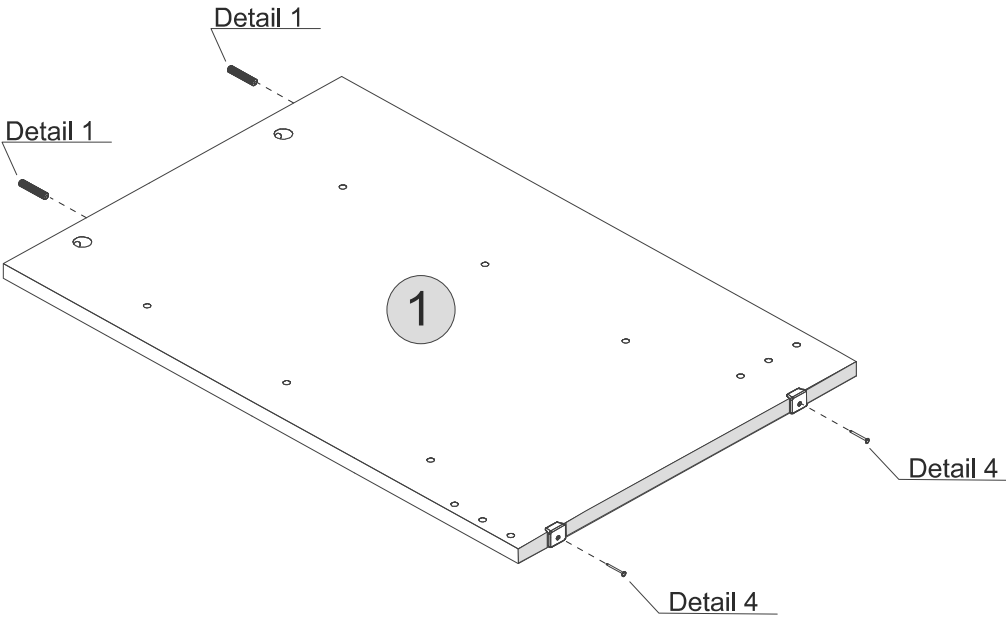
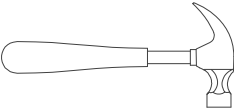

Detail 1

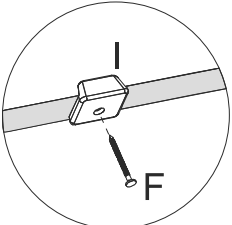

Detail 4

STEP 2

PARTS REQUIRED

2 - RIGHT SIDE PANEL x1

HARDWARE REQUIRED

E  02
Ø6,0 x 30mm

F  02
10 x 10

I  02

K  01
GLUE

TOOLS REQUIRED

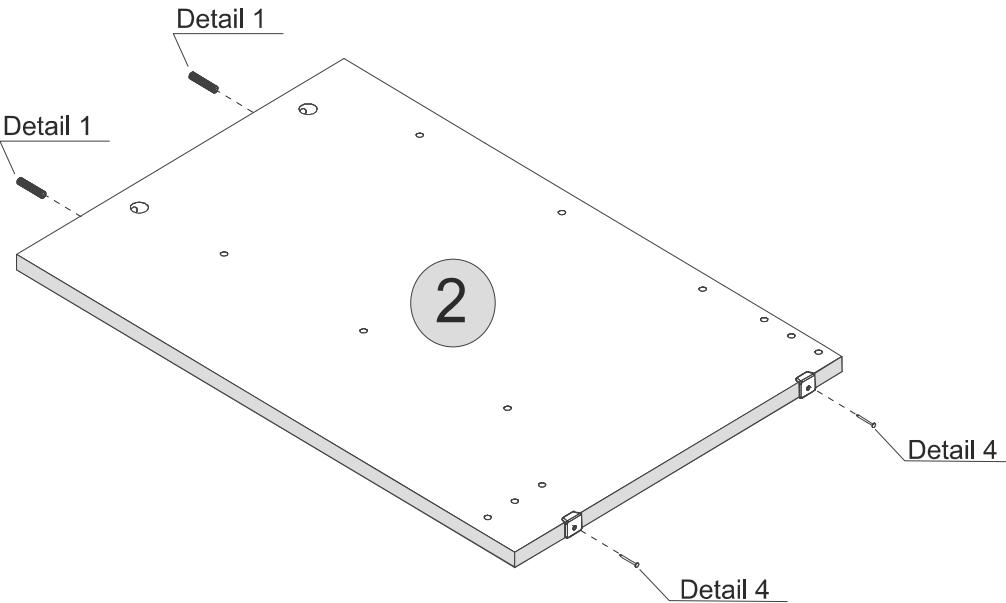
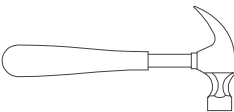

Detail 1

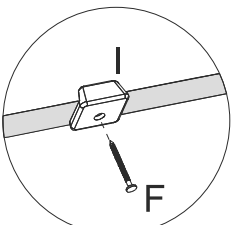

Detail 4

STEP 3

PARTS REQUIRED

2 - RIGHT SIDE PANEL x1

HARDWARE REQUIRED

A  06
Ø6.0 x 10mm

B  03
Ø4.0 x 14mm

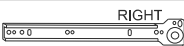
M  03
RIGHT

TOOLS REQUIRED

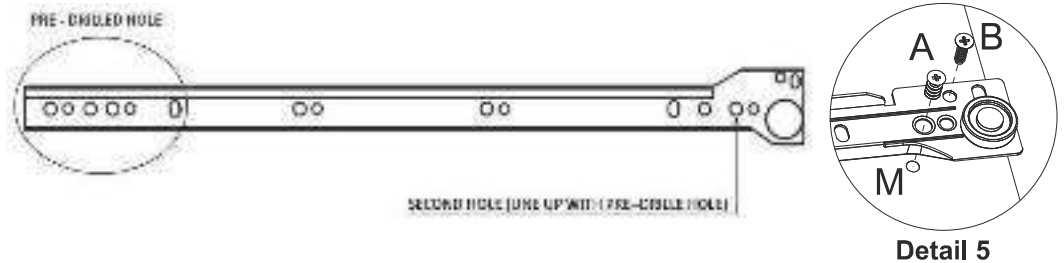
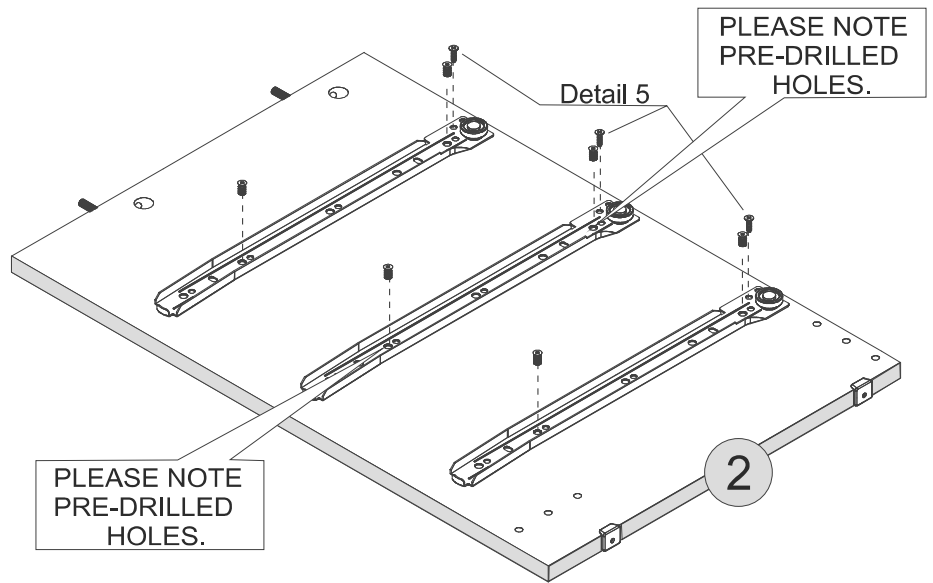



STEP 4

PARTS REQUIRED

1 - LEFT SIDE PANEL x1

HARDWARE REQUIRED

A  06
Ø6.0 x 10mm

B  03
Ø4.0 x 14mm

M  03
LEFT

TOOLS REQUIRED

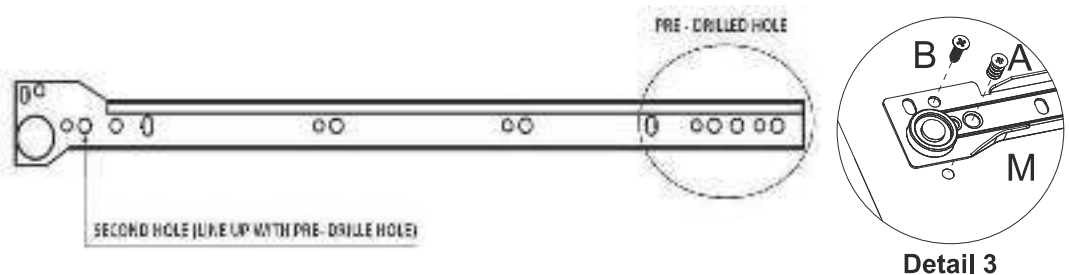
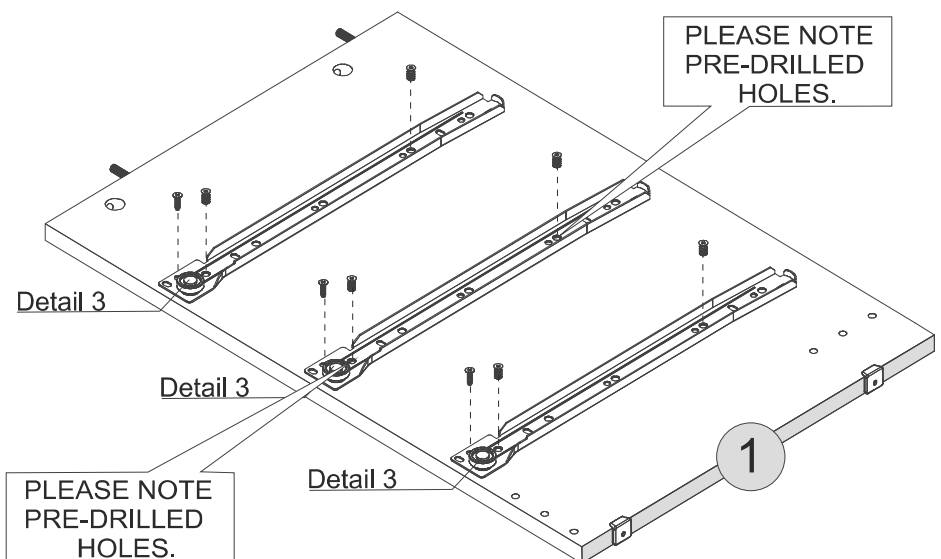

STEP 5

PARTS REQUIRED

9 - BACK BASEBOARD x1

4 - FRONT BASEBOARD x1

HARDWARE REQUIRED

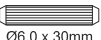
E  08
Ø6,0 x 30mm

K  01
GLUE

TOOLS REQUIRED

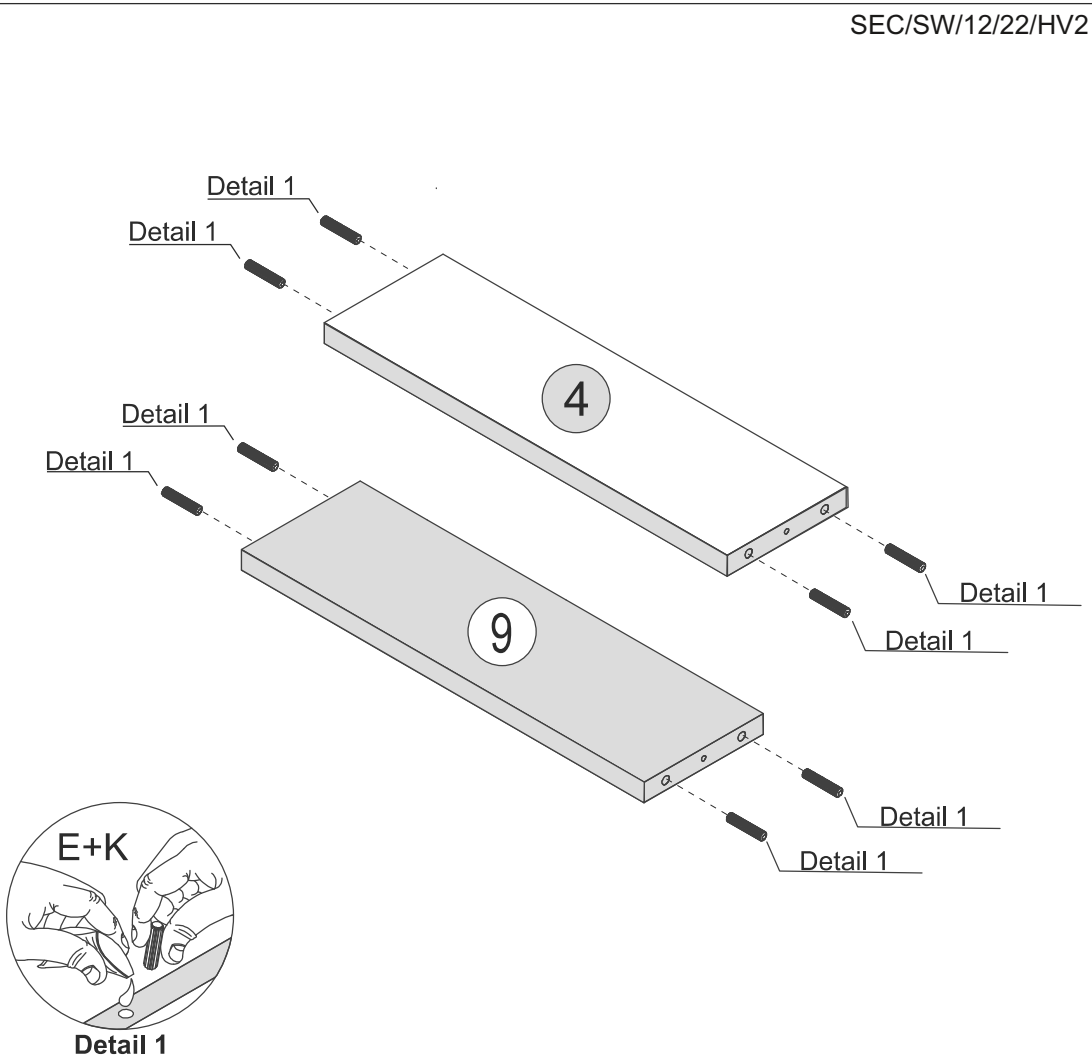

STEP 6

PARTS REQUIRED

2 - RIGHT SIDE PANEL x1

9 - BACK BASEBOARD x1

4 - FRONT BASEBOARD x1

HARDWARE REQUIRED

D  02
Ø4 x 50mm

K  01
GLUE

TOOLS REQUIRED

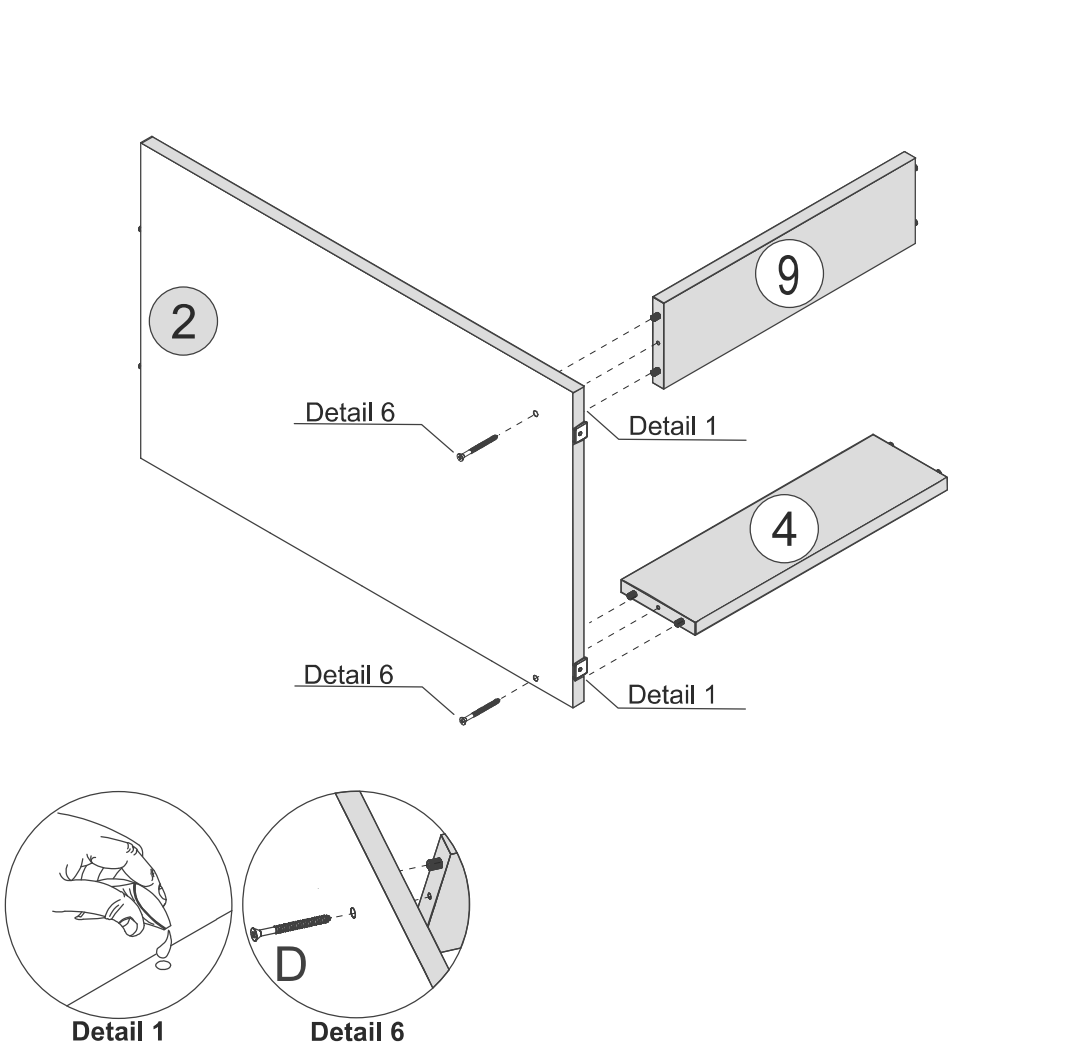
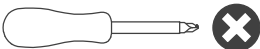

STEP 7

PARTS REQUIRED

1 - LEFT SIDE PANEL x1

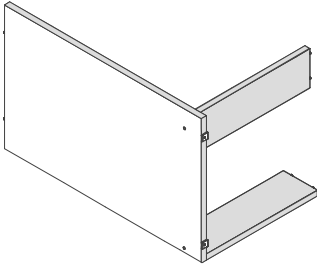

HARDWARE REQUIRED

D  02
Ø4 x 50mm

K  01
GLUE

TOOLS REQUIRED

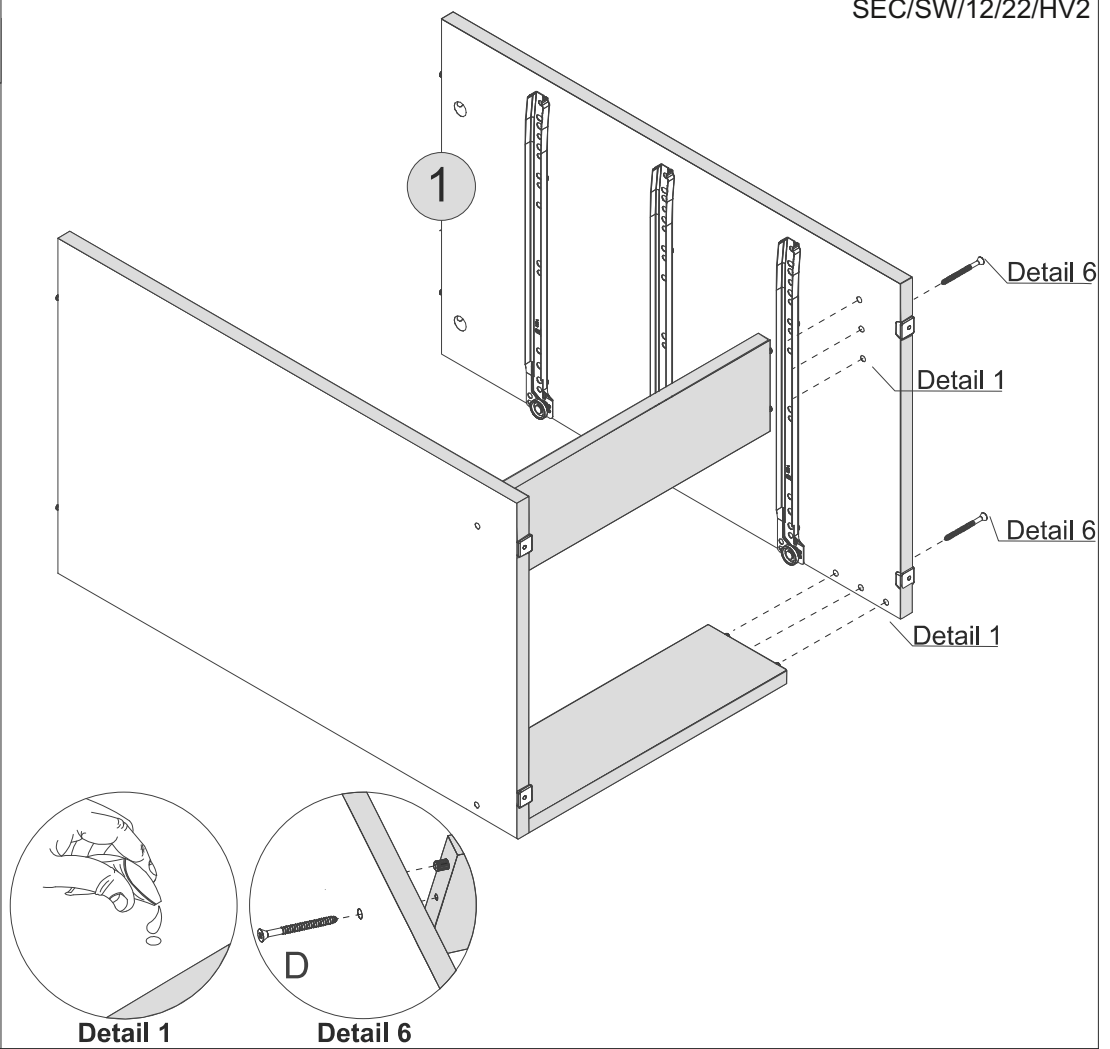
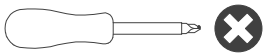

STEP 8

PARTS REQUIRED

3 - TOP PANEL x1

HARDWARE REQUIRED

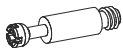
G  04

TOOLS REQUIRED

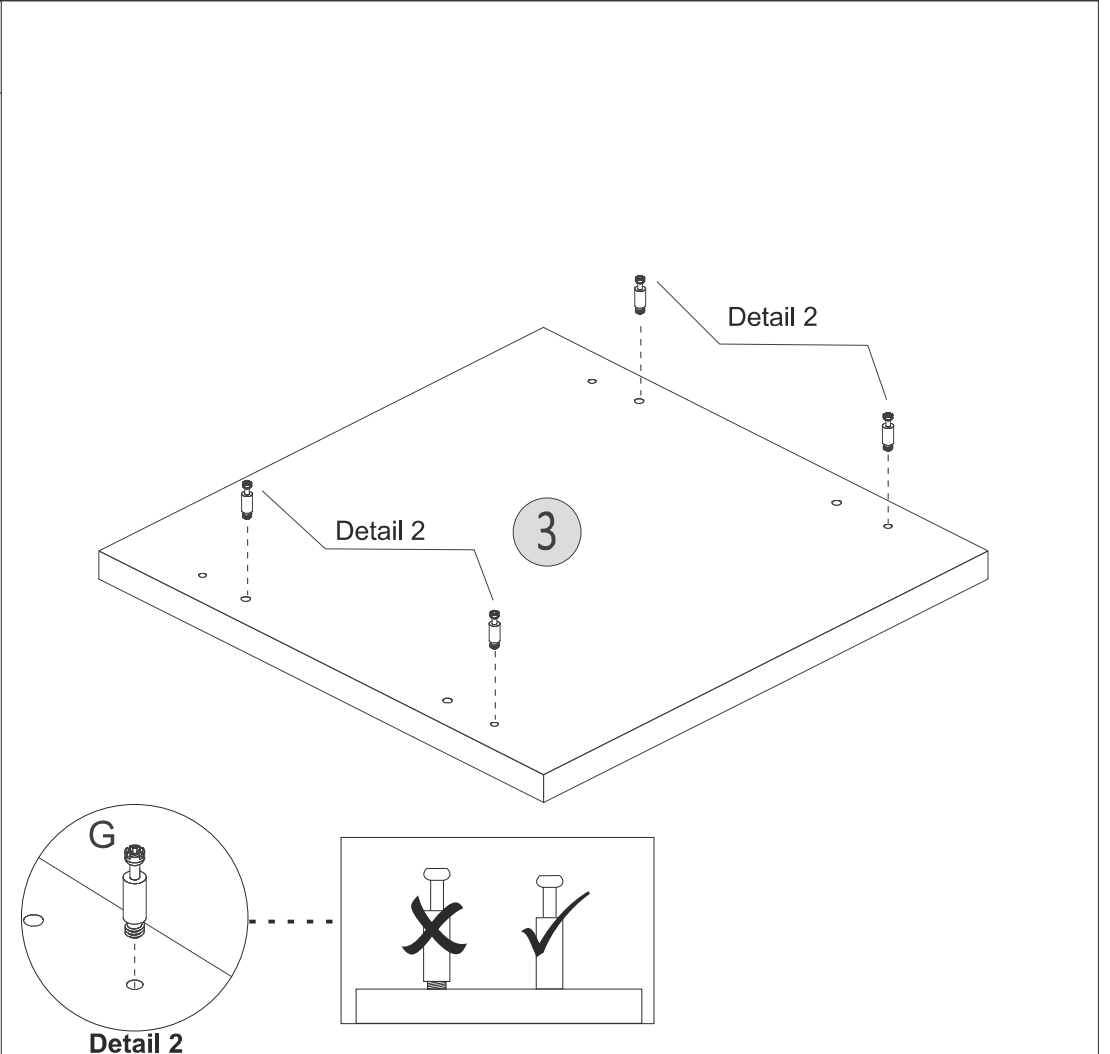
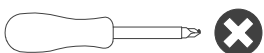

STEP 9

PARTS REQUIRED

3 - TOP PANEL x1

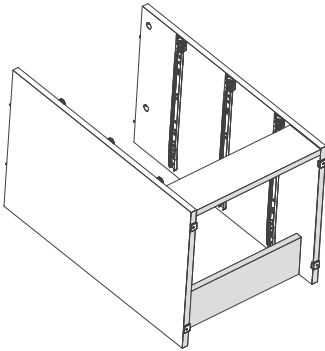

HARDWARE REQUIRED

K  01

N  04

TOOLS REQUIRED

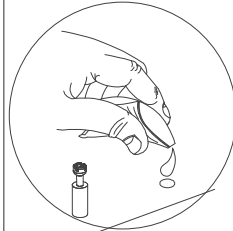
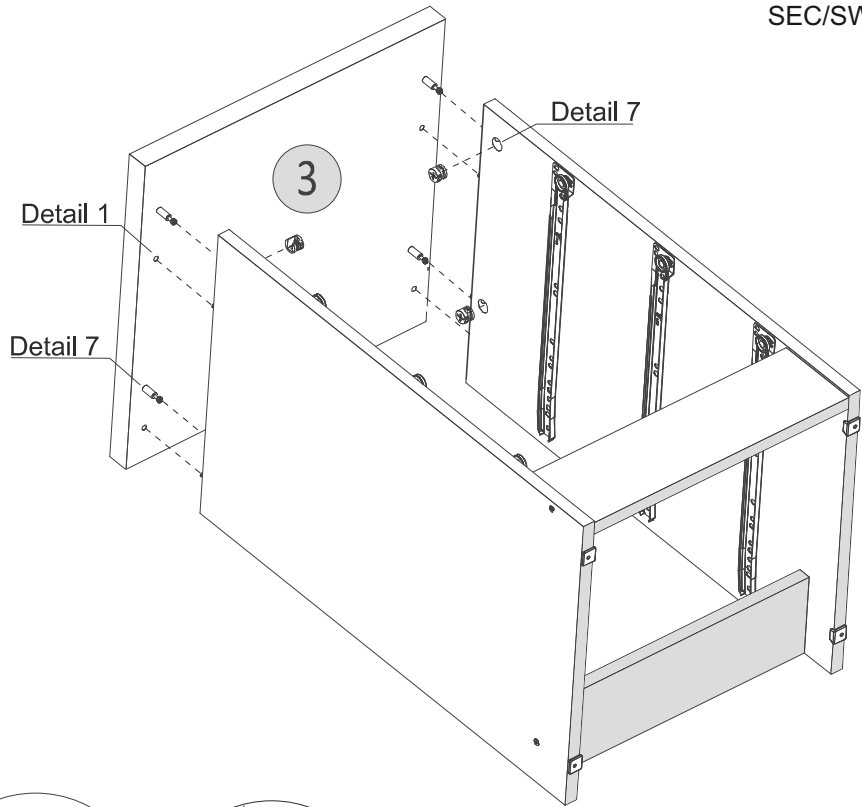
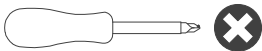

Detail 1

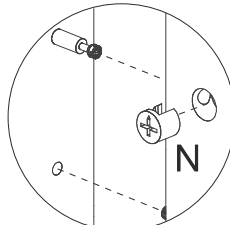

Detail 7

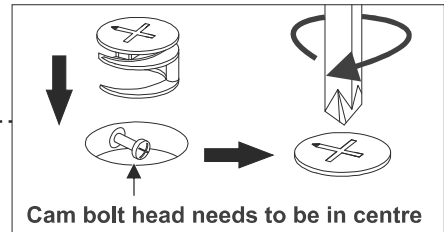

Cam bolt head needs to be in centre

STEP 10

PARTS REQUIRED

10 - BACK PANEL x1

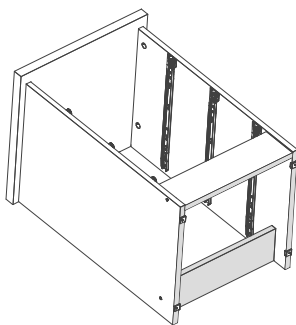

HARDWARE REQUIRED

F  14

TOOLS REQUIRED

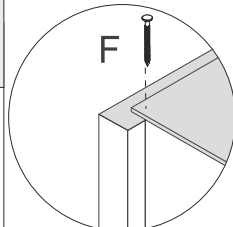
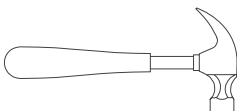

Detail 8

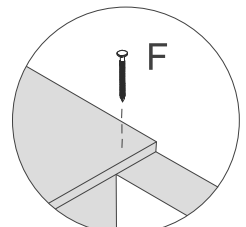
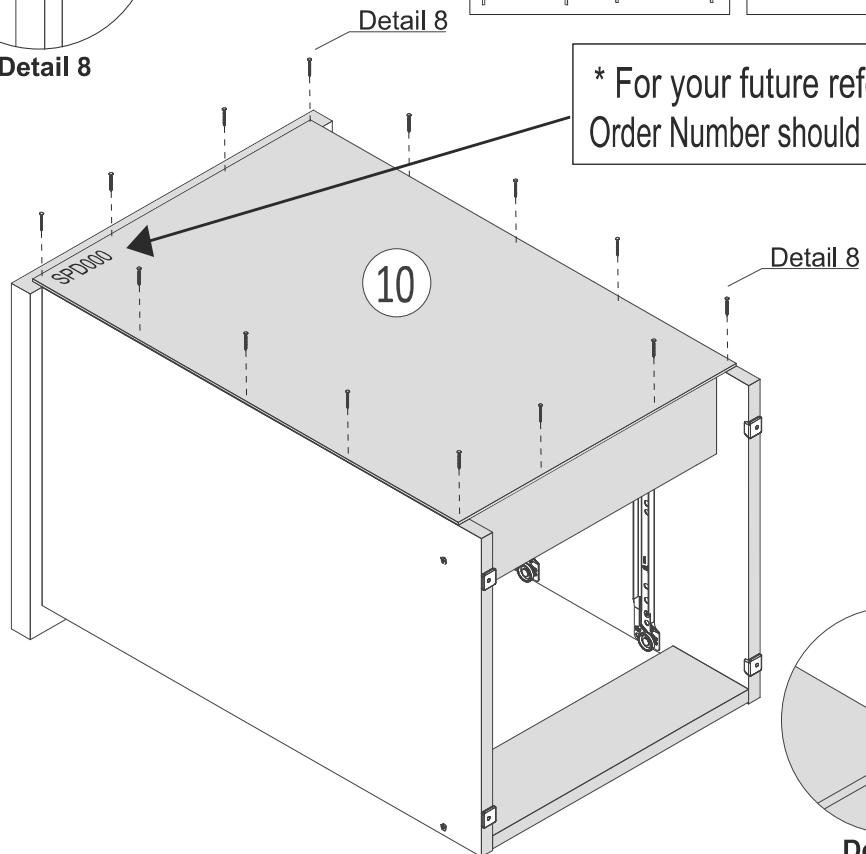
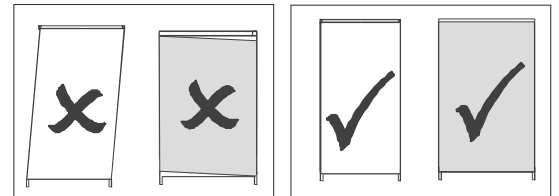

Detail 8

STEP 11

PARTS REQUIRED

6 - DRAWER SIDE x6

7 - DRAWER BACK PANEL x3

HARDWARE REQUIRED

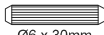
E  24
Ø6 x 30mm

K  01
GLUE

TOOLS REQUIRED

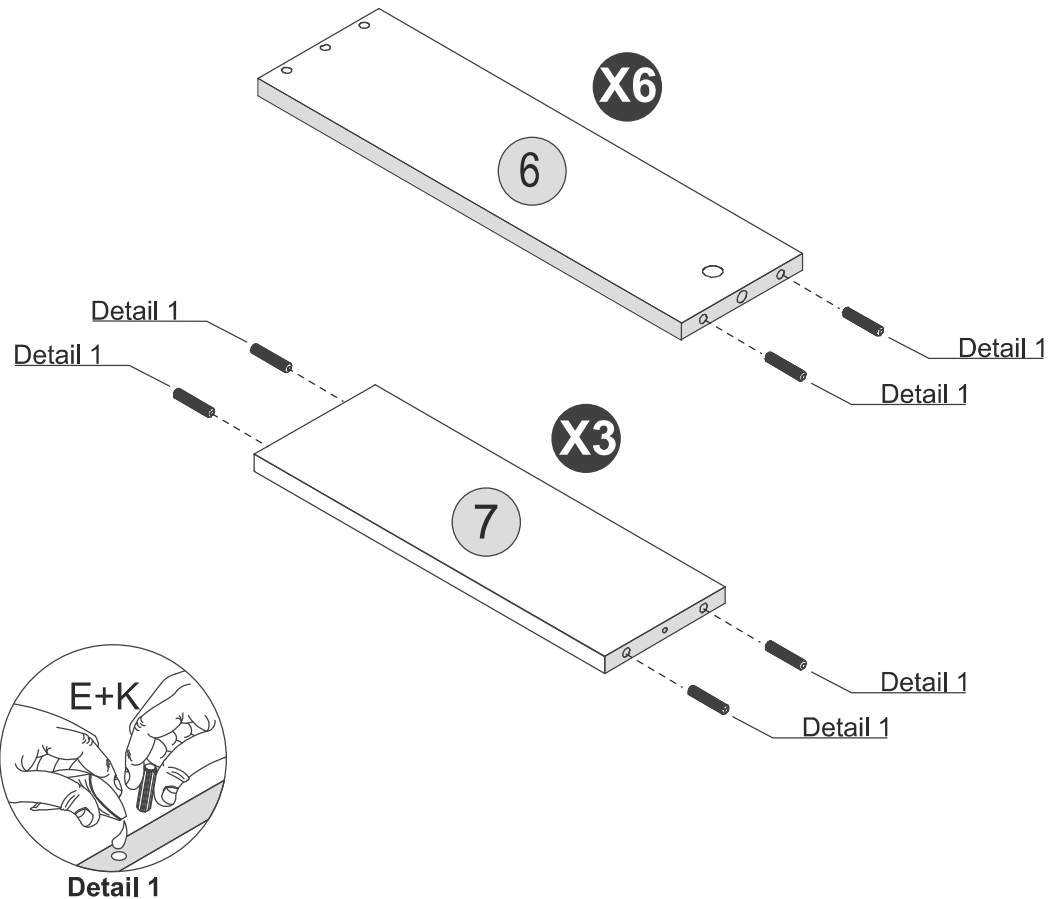

STEP 12

PARTS REQUIRED

5 - DRAWER FRONT x3

HARDWARE REQUIRED

G  06

TOOLS REQUIRED

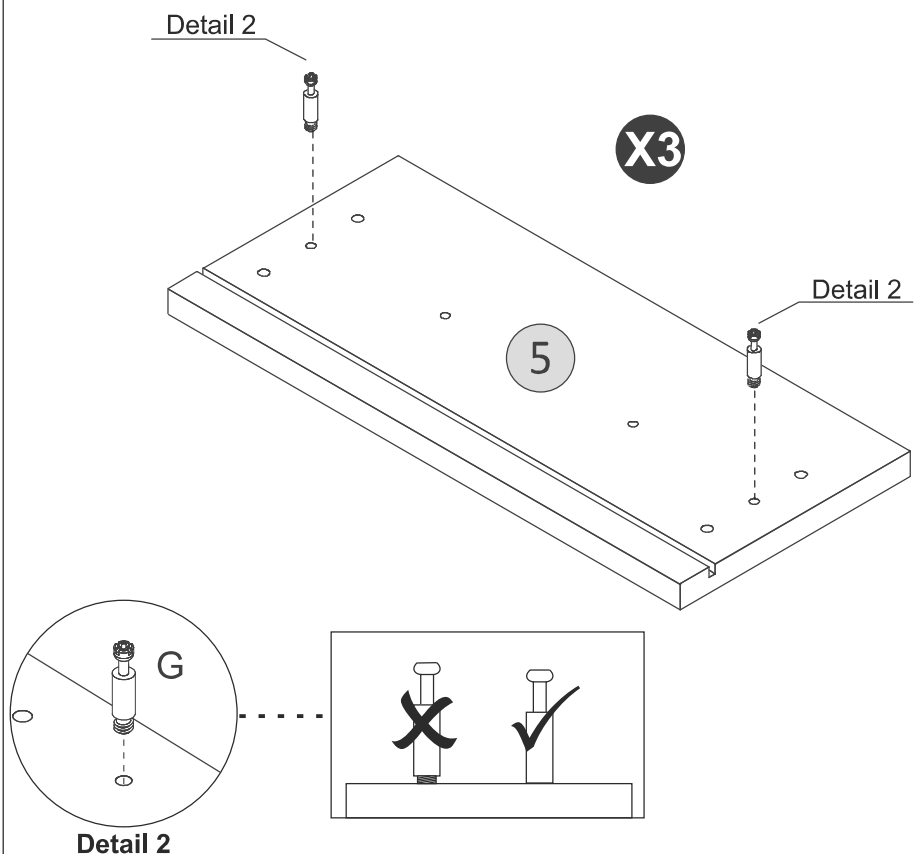

STEP 13

PARTS REQUIRED

6 - DRAWER SIDE x6

7 - DRAWER BACK PANEL x3

HARDWARE REQUIRED

D  06
Ø4 x 50mm

TOOLS REQUIRED

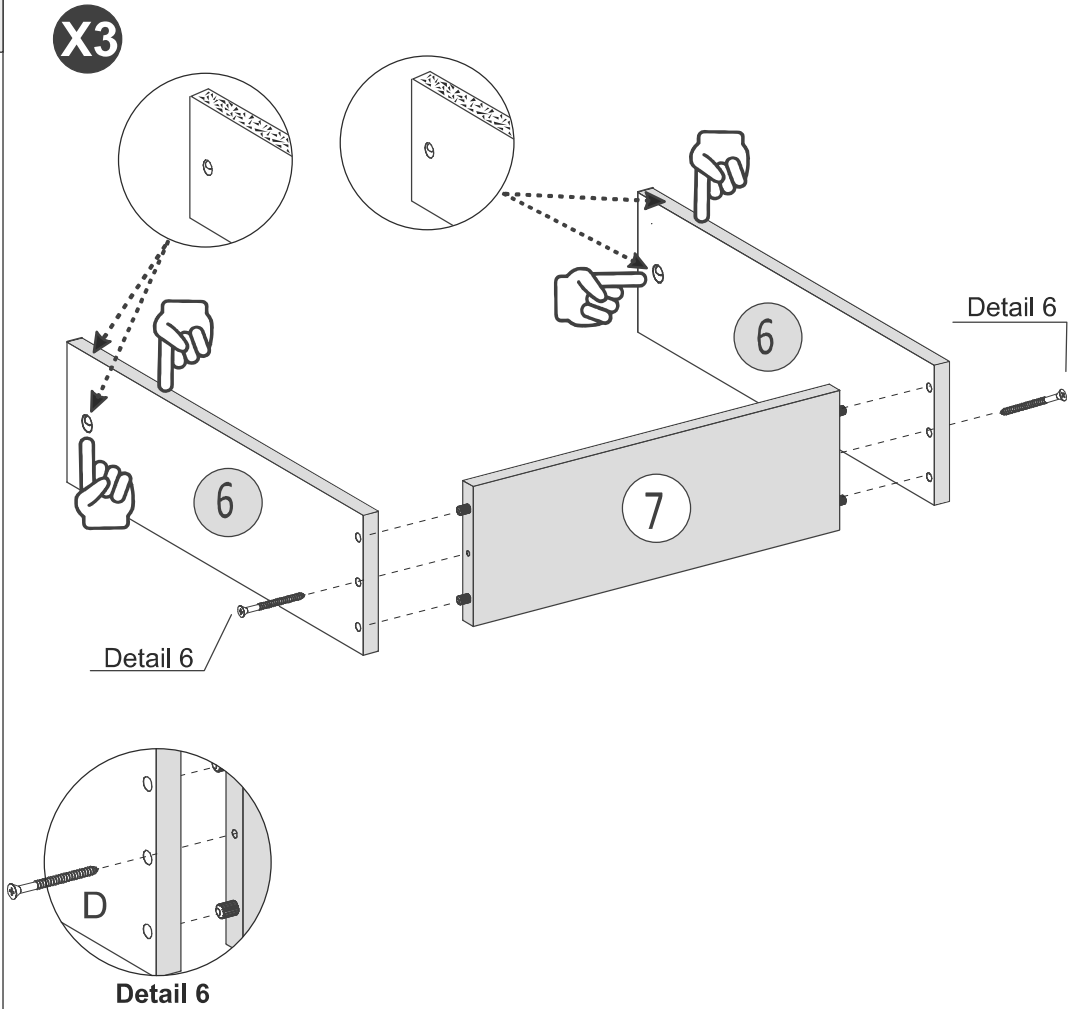
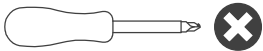

STEP 14

PARTS REQUIRED

5 - DRAWER FRONT x3

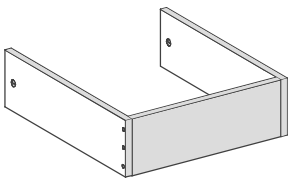

HARDWARE REQUIRED

H  06

K  01
GLUE

TOOLS REQUIRED

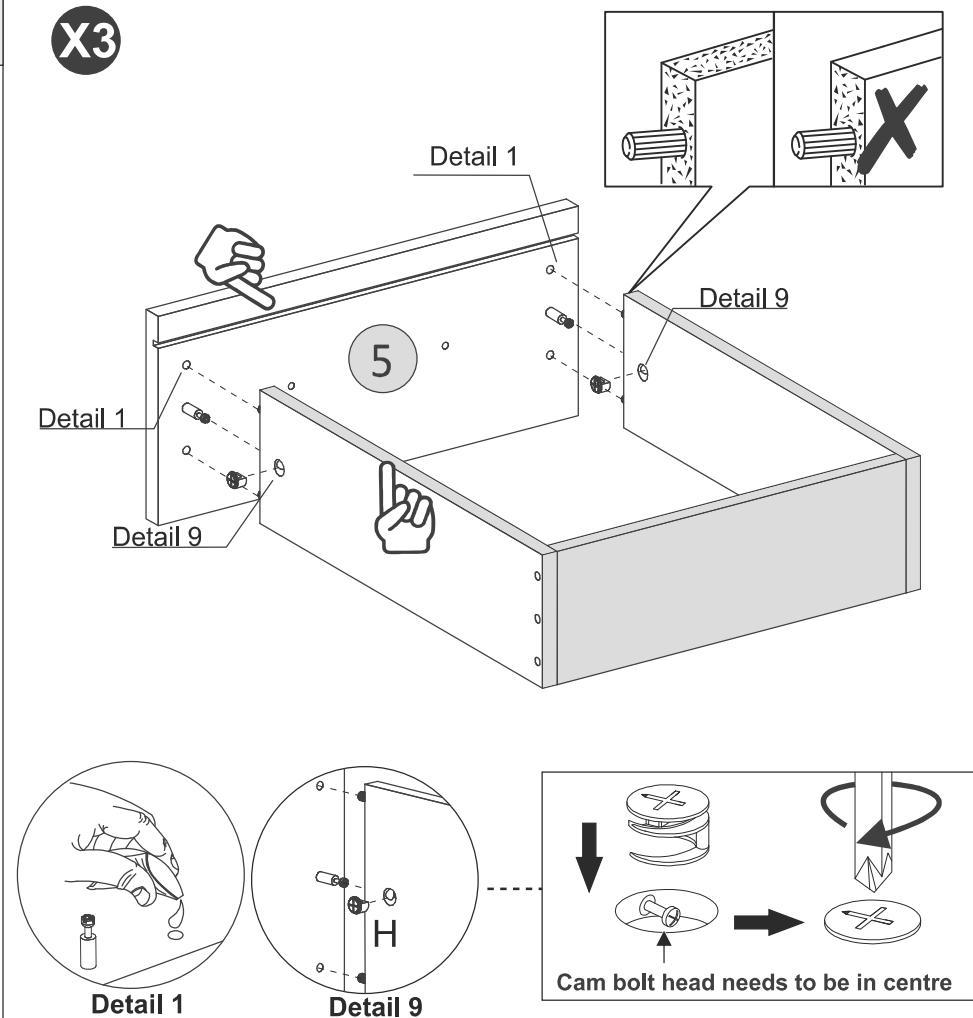
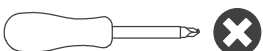

STEP 15

SEC/SW/12/22/HV2

PARTS REQUIRED

8 - DRAWER BOTTOM x3

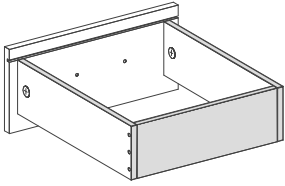

HARDWARE REQUIRED

F  12
10 x 10

TOOLS REQUIRED

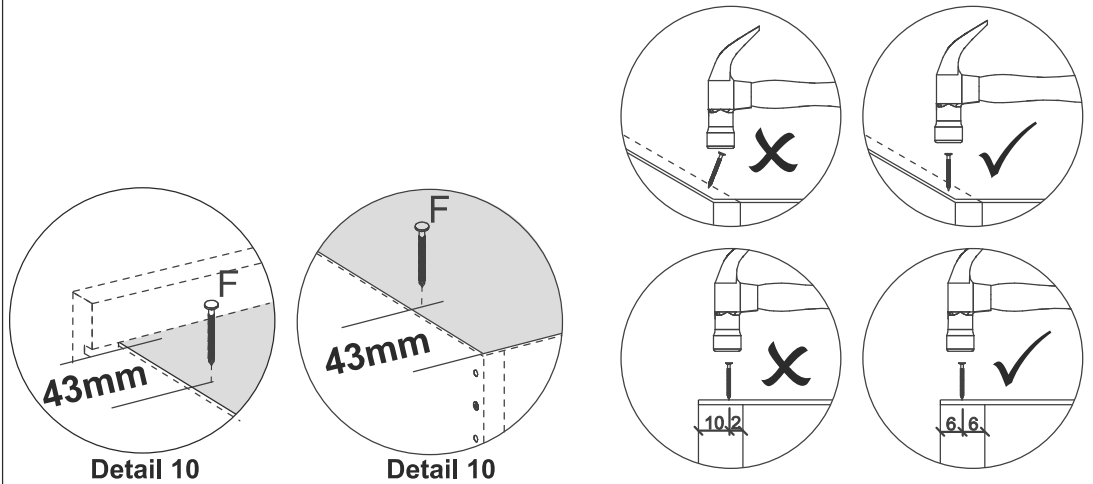
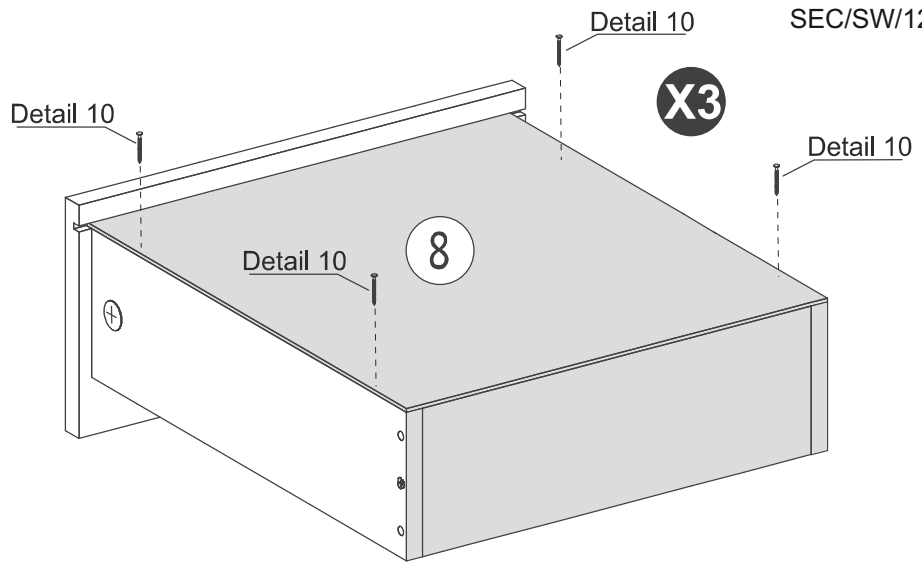
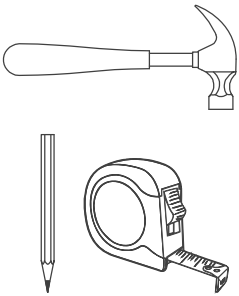

STEP 16

PARTS REQUIRED

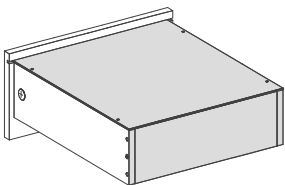

HARDWARE REQUIRED

F  12
10 x 10

TOOLS REQUIRED

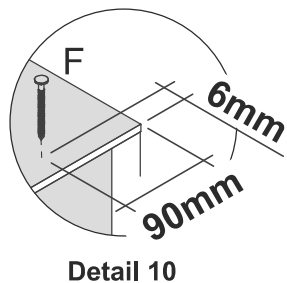
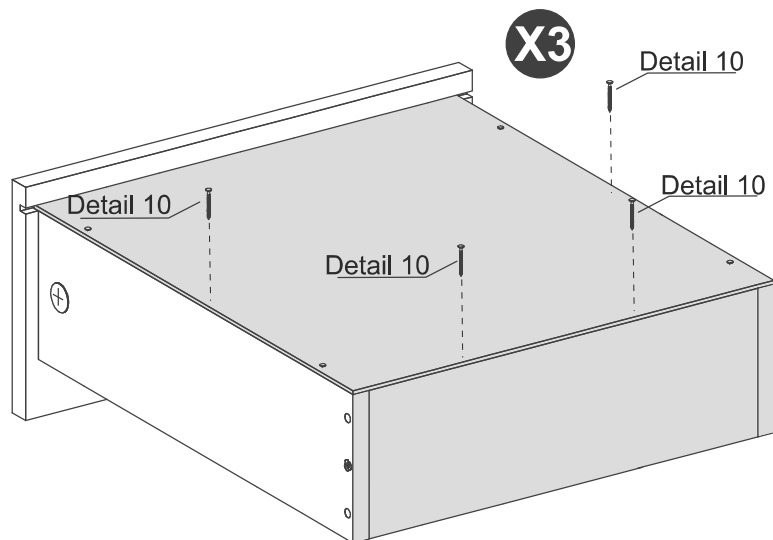
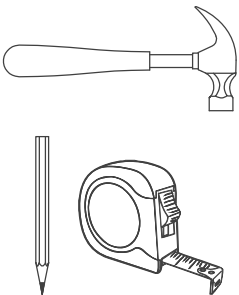

STEP 17

PARTS REQUIRED

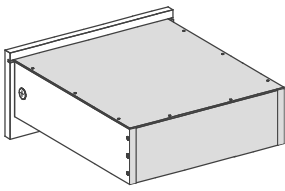

HARDWARE REQUIRED

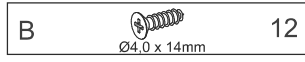

TOOLS REQUIRED

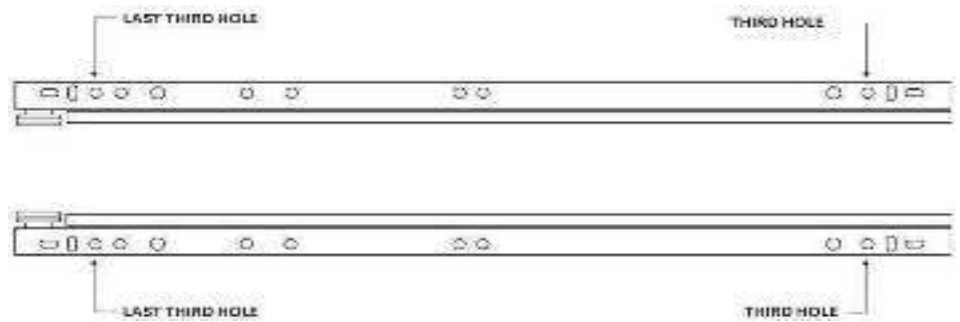
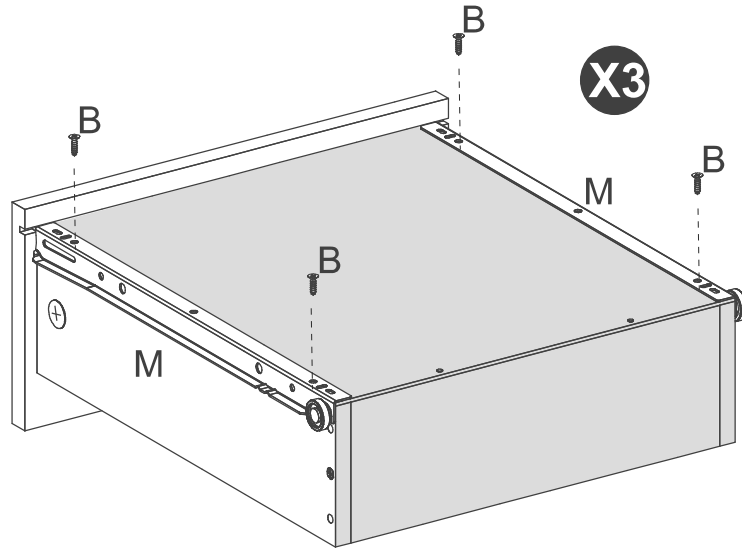
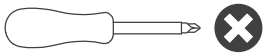

STEP 18

PARTS REQUIRED

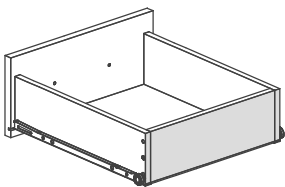

HARDWARE REQUIRED

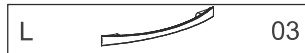
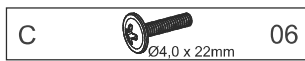

TOOLS REQUIRED

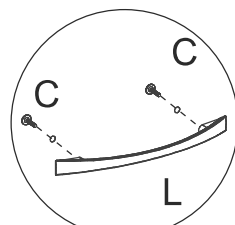
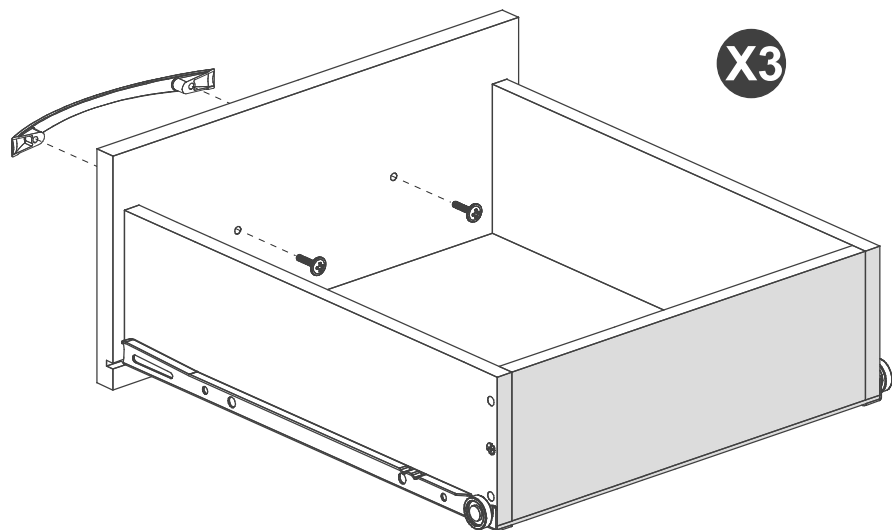
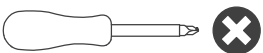

Detail 11

STEP 19

PARTS REQUIRED

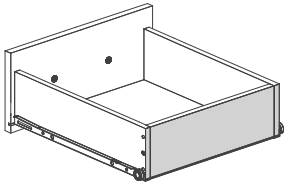

HARDWARE REQUIRED



TOOLS REQUIRED

X3

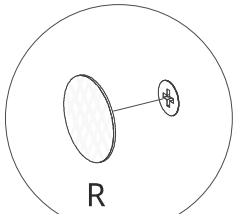
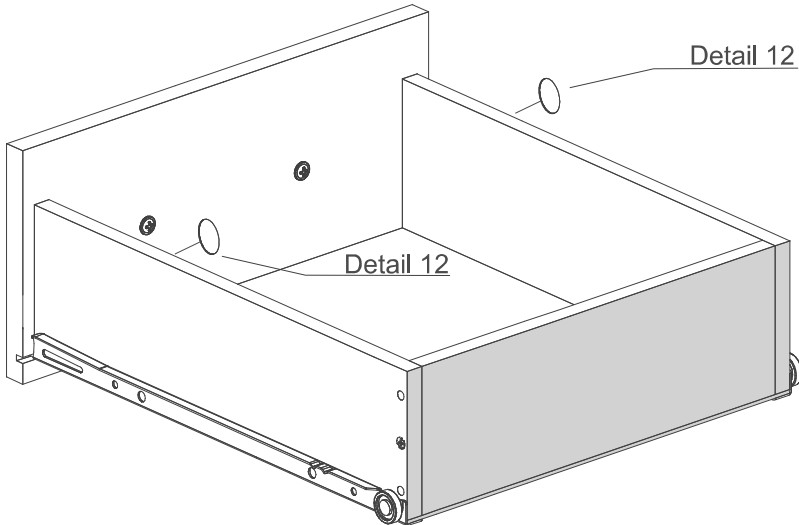

Detail 12

STEP 20

PARTS REQUIRED

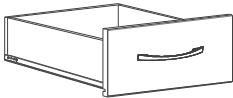

HARDWARE REQUIRED



TOOLS REQUIRED

See the last page

TIP
If desired, after assembly use an alcohol cleaner to erase the number printed on the parts.

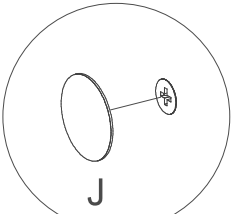
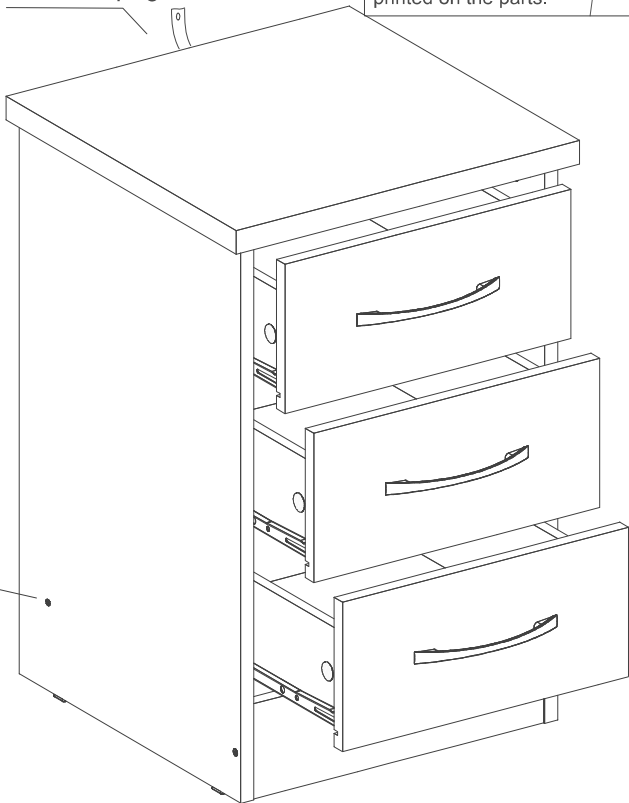

Detail 12

WARNING

Serious or fatal injuries can occur from furniture tipping over. To prevent the furniture from tipping over we recommend that it is permanently fixed to the wall.

Wall fixings are not supplied with this product as different wall materials require different types of fixing devices.

Please make sure you use fixings suitable for the walls in your home.

