

WHITE GLOSS SEVILLE 2 DOOR WARDROBE ASSEMBLY INSTRUCTIONS

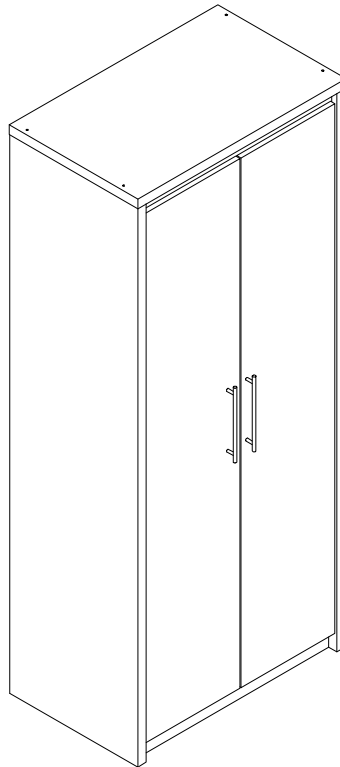

FOR DOMESTIC USE ONLY
IMPORTANT

PLEASE READ BEFORE YOU CONTINUE FURTHER

THE PRODUCT YOU HAVE PURCHASED WILL GIVE YOU MANY YEARS OF SERVICE IF YOU FOLLOW THE GUIDELINES FOR ITS SAFE ASSEMBLY AND PERIODIC MAINTENANCE AND CLEANING.

ASSEMBLE ON A SOFT CLEAN SURFACE.

DO NOT USE ANY TOOLS OTHER THAN THOSE SHOWN.

ANY SPANNERS OR ALLEN KEYS REQUIRED ARE INCLUDED WITH THE FITTING KIT.

DO NOT FOR ANY REASON USE A POWER TOOL TO ASSEMBLE THIS PRODUCT. ITS USE WILL INVALIDATE ANY CLAIM YOU MAY HAVE AND COULD MAKE THIS PRODUCT UNSAFE.

DEPENDING ON THE AMOUNT OF USE THIS PRODUCT RECEIVES, IT MAY BE NECESSARY TO TIGHTEN UP THE FIXINGS FROM TIME TO TIME. THIS IS COMPLETELY NORMAL FOR ANY FLAT PACK FURNITURE. DO NOT OVERTIGHTEN FIXINGS.

FOR CLEANING, YOU MAY USE A DAMP CLOTH (NOT WET). DO NOT USE POLISH, DETERGENT OR CHEMICAL CLEANERS.



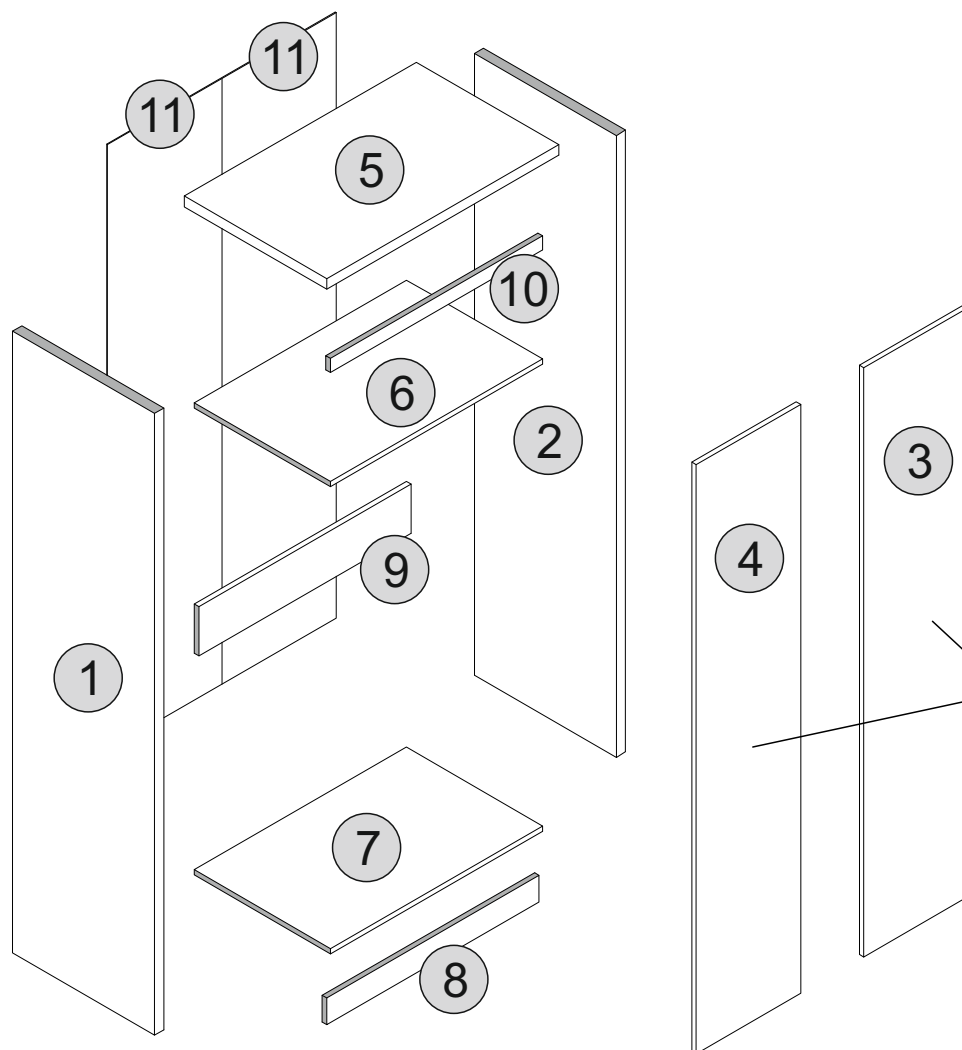









THIS SURFACE OF THIS ITEM IS NOT HEAT RESISTANT. ALWAYS USE A PLACE MAT UNDER HOT OR COLD ITEMS TO PREVENT MARKING.



PART LIST

| Part Number | Part Code | Part Description | Quantity | Carton |
|-------------|---------------------|------------------|----------|--------|
| 1 | S100-101-045-ZF1-01 | Left Side Panel | 1 | 1/2 |
| 2 | S100-101-045-ZF1-02 | Right Side Panel | 1 | 1/2 |
| 3 | S100-101-045-ZF1-03 | Right Door Panel | 1 | 1/2 |
| 4 | S100-101-045-ZF1-04 | Left Door Panel | 1 | 1/2 |
| 5 | S100-101-045-ZF1-05 | Top Panel | 1 | 2/2 |
| 6 | S100-101-045-ZF1-06 | Shelf | 1 | 2/2 |
| 7 | S100-101-045-ZF1-07 | Bottom Panel | 1 | 2/2 |
| 8 | S100-101-045-ZF1-08 | Crossbar | 1 | 2/2 |
| 9 | S100-101-045-ZF1-09 | Back Support | 1 | 2/2 |
| 10 | S100-101-045-ZF1-10 | Support Panel | 1 | 2/2 |
| 11 | S100-101-045-ZF1-11 | Back Panel | 2 | 1/2 |

HARDWARE LIST

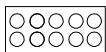
| No. | Part Name | | Qty |
|-----|----------------------------|---|-----|
| A | Wooden Dowel (6x25mm) |  | x22 |
| B | 65mm Screw (4x65mm) |  | x14 |
| C | 14mm Screw (3.5x14mm) |  | x38 |
| D | Hanging Rail (689mm) |  | x1 |
| E | 3mm Hinges (M11) |  | x6 |
| F | Hanging Rail Support |  | x2 |
| G | 10" Handle (192mm) |  | x2 |
| H | 20mm Handle Screw |  | x4 |
| I | PVC L - Bracket |  | x2 |
| J | Plastic Foot |  | x5 |
| K | 6/8" Nail |  | x58 |
| L | Wall Fixings |  | x1 |
| M | Screw Cover (Sticker 12mm) |  | x10 |

TIPS FOR FITTINGS CAM-LOCKS

WHEN FITTING CAM NUT. ENSURE STARTING POSITION IS CORRECT BEFORE YOU INSERT CONNECTING CAM BOLT TURN CLOCKWISE UNTIL SECURE

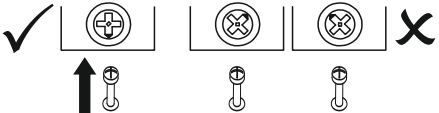

CORRECT **WRONG**

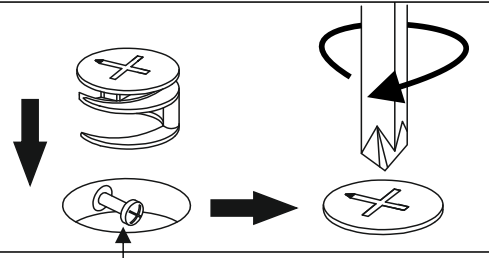

Cam bolt head needs to be in centre

CAMBOLT

Tighten until shoulder in flush with panel. Do not overtighten or undertighten (see example below)

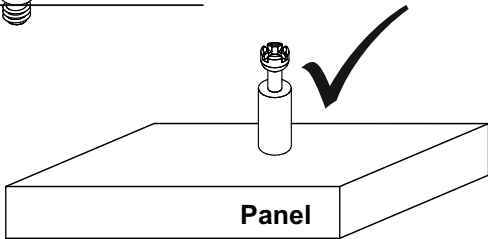
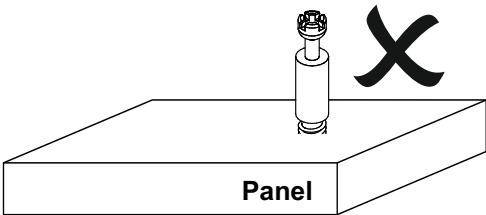
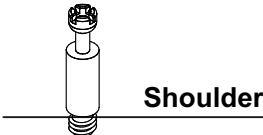





STEP 1

PARTS REQUIRED

1 - LEFT SIDE PANEL x1

HARDWARE REQUIRED

| | | |
|---|---|----|
| A |  | 02 |
| C |  | 02 |
| F |  | 01 |
| J |  | 02 |

TOOLS REQUIRED

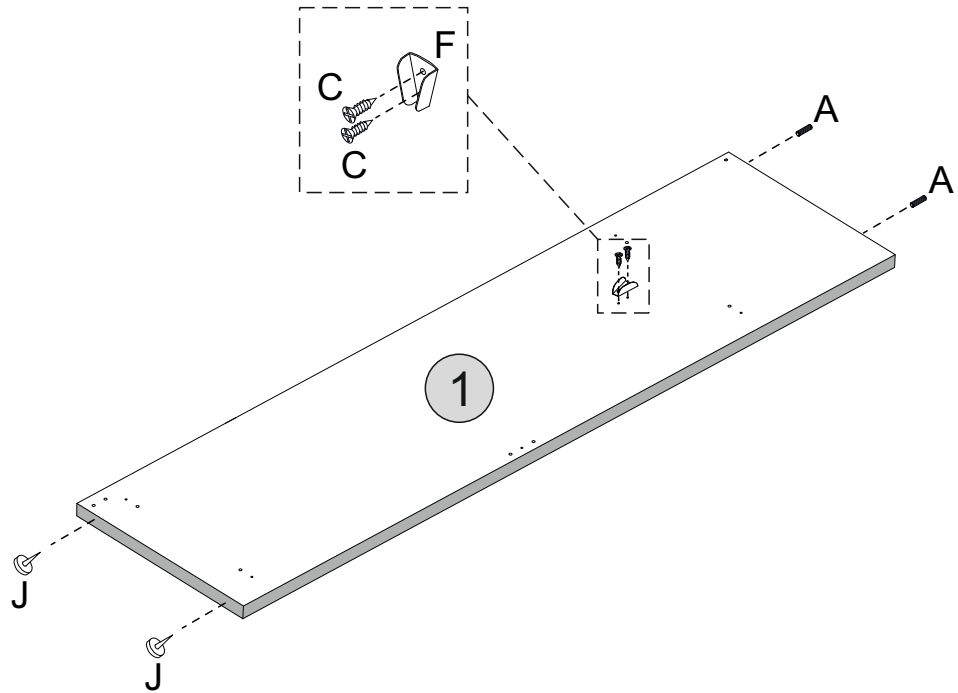
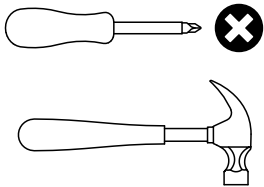





STEP 2

PARTS REQUIRED

2 - RIGHT SIDE PANEL x1

HARDWARE REQUIRED

| | | |
|---|---|----|
| A |  | 02 |
| C |  | 02 |
| F |  | 01 |
| J |  | 02 |

TOOLS REQUIRED

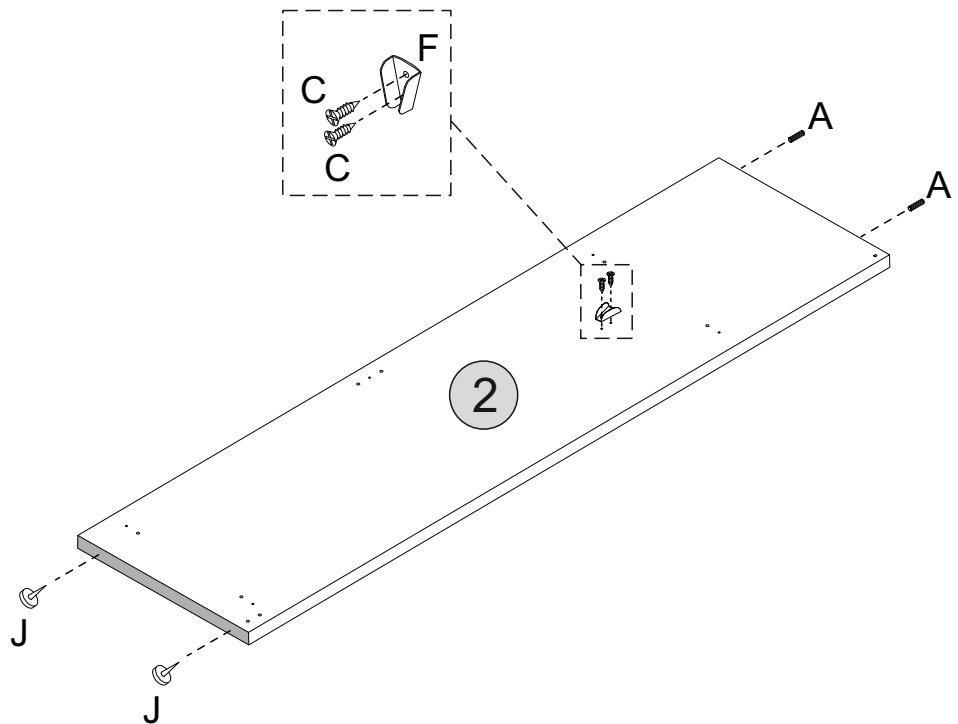
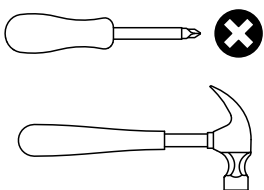

STEP 3

PARTS REQUIRED

6 - SHELF x1

7 - BOTTOM PANEL x1

HARDWARE REQUIRED

A  08

TOOLS REQUIRED

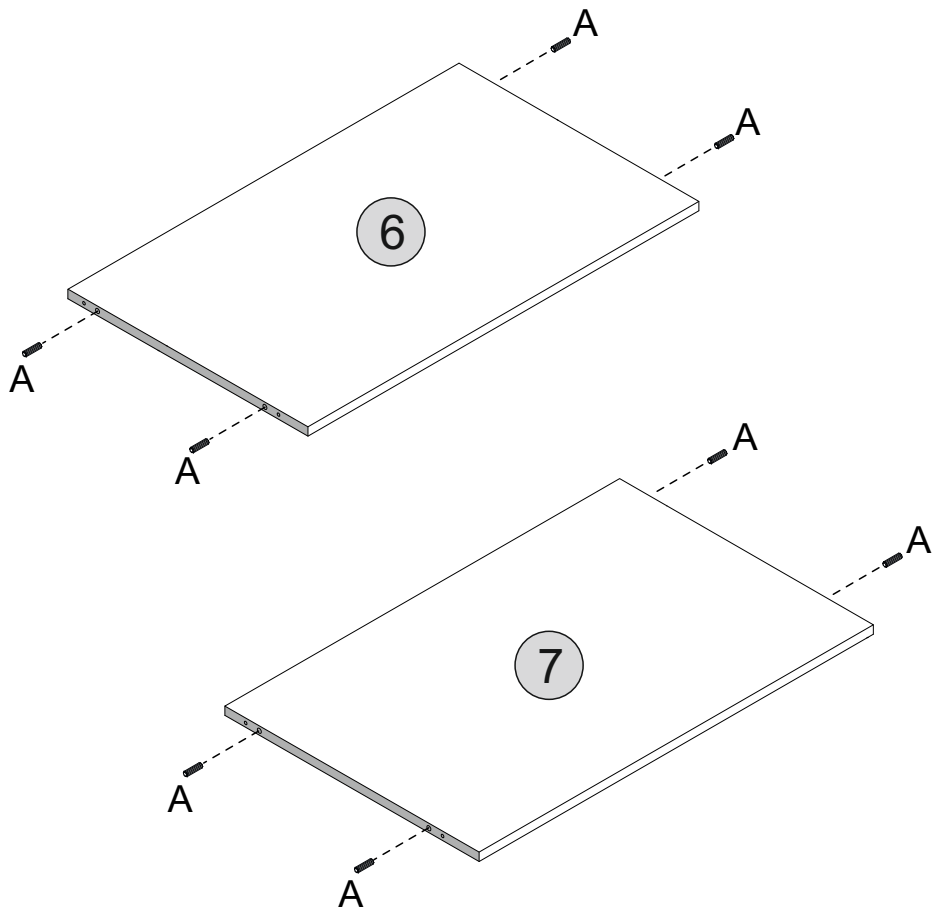

STEP 4

PARTS REQUIRED

8 - CROSSBAR x1

9 - BACK SUPPORT x1

10 - SUPPORT PANEL x1

HARDWARE REQUIRED

A  10

J  01

TOOLS REQUIRED

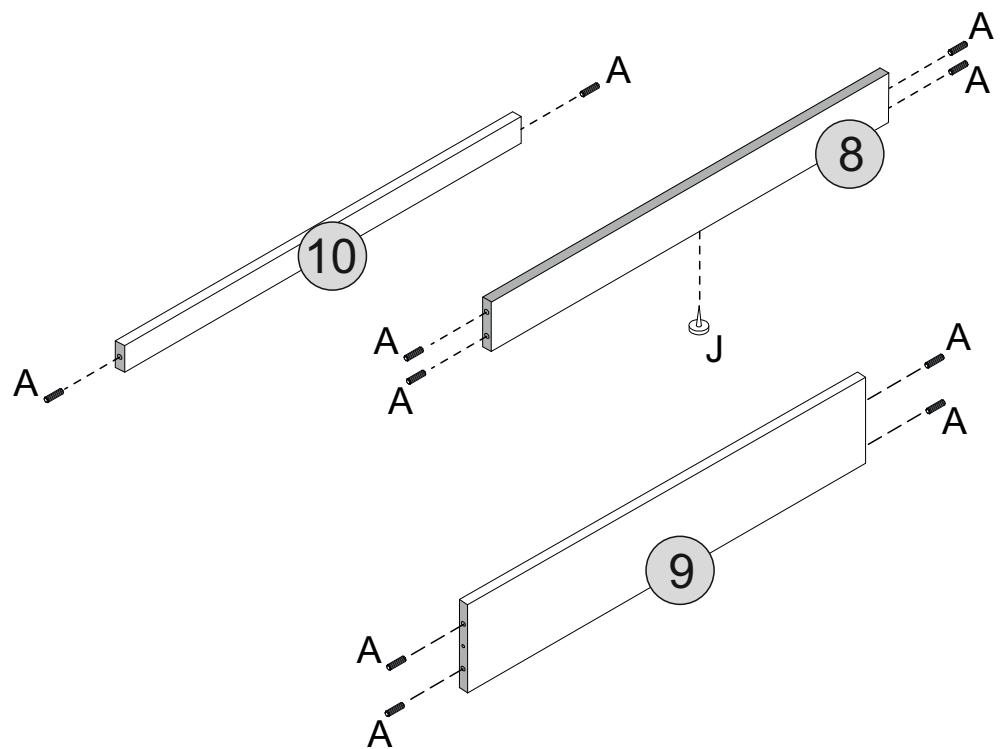
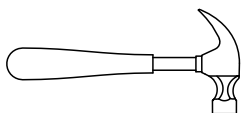



STEP 5

PARTS REQUIRED

| | |
|---------------------|----|
| 1 - LEFT SIDE PANEL | x1 |
| 6 - SHELF | x1 |
| 7 - BOTTOM PANEL | x1 |
| 9 - BACK SUPPORT | x1 |

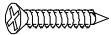
HARDWARE REQUIRED

| | | |
|---|---|----|
| B |  | 05 |
| M |  | 05 |

TOOLS REQUIRED

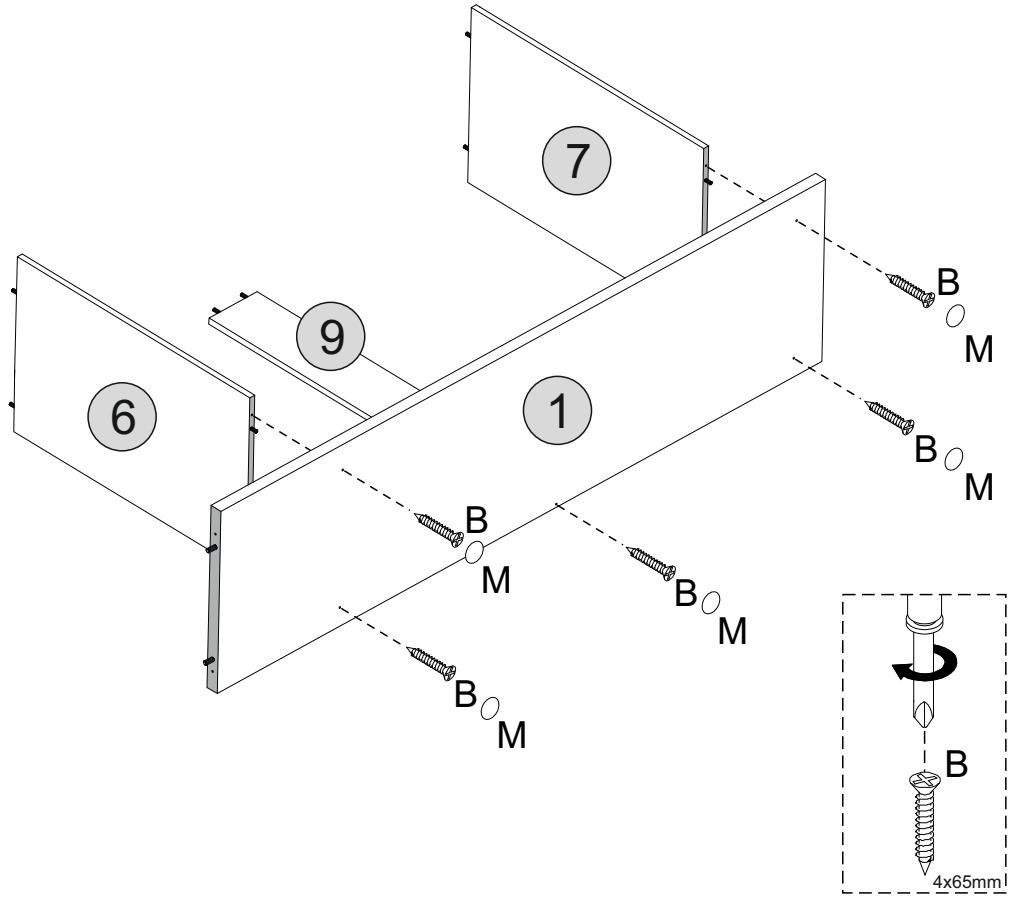
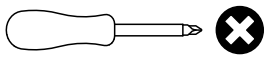



STEP 6

PARTS REQUIRED

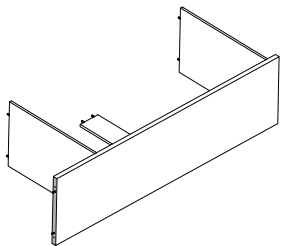
| | |
|----------------------|----|
| 2 - RIGHT SIDE PANEL | x1 |
| 8 - CROSSBAR | x1 |
| 10 - SUPPORT PANEL | x1 |



HARDWARE REQUIRED

| | | |
|---|---|----|
| B |  | 05 |
| M |  | 05 |

TOOLS REQUIRED

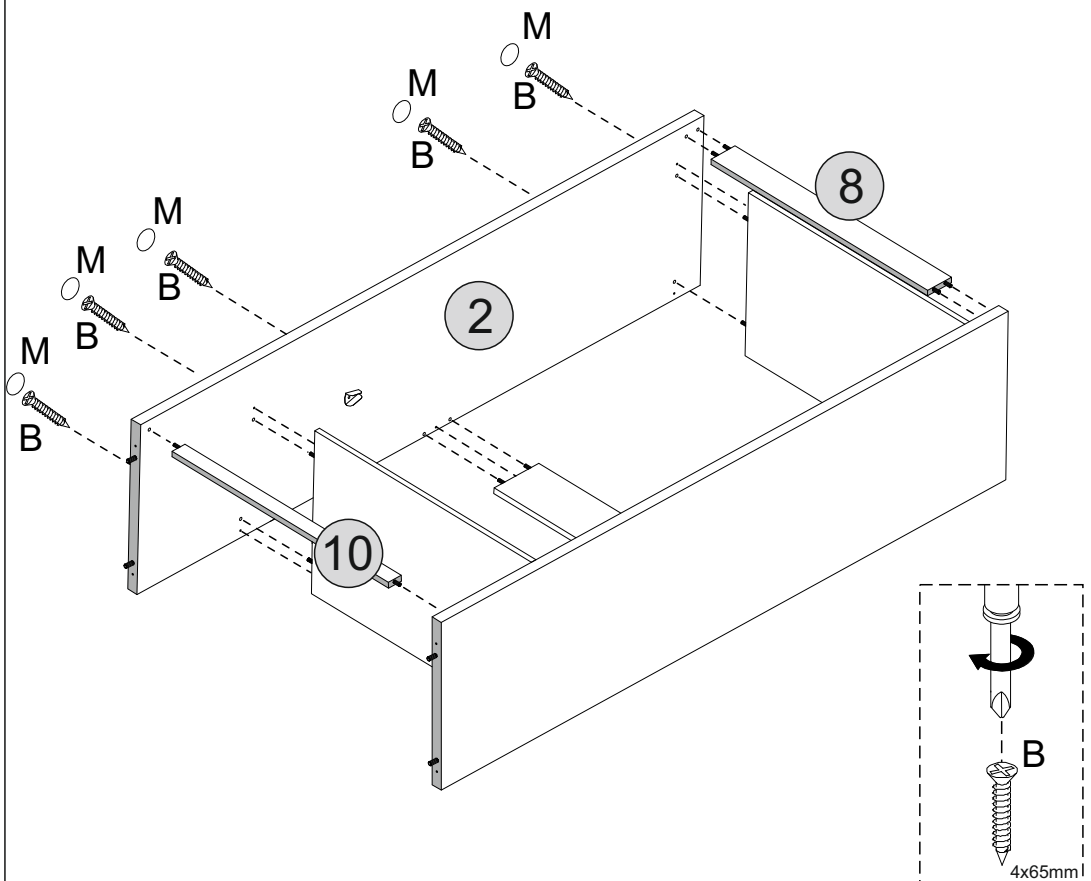
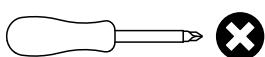

STEP 7

PARTS REQUIRED

5 - TOP PANEL x1

HARDWARE REQUIRED

C  02

I  01

TOOLS REQUIRED

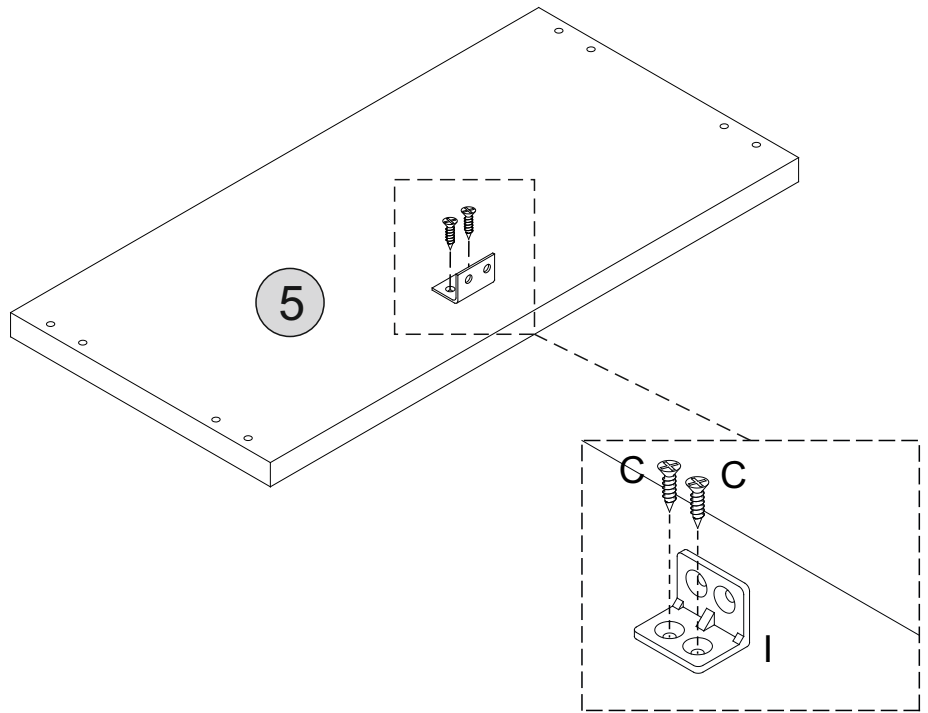
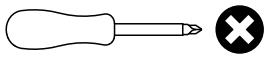

STEP 8

PARTS REQUIRED

5 - TOP PANEL x1

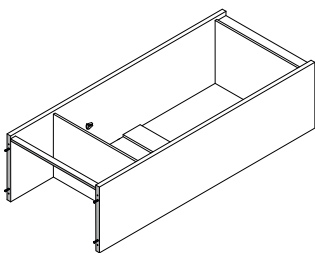

HARDWARE REQUIRED

B  04

C  06

I  01

TOOLS REQUIRED

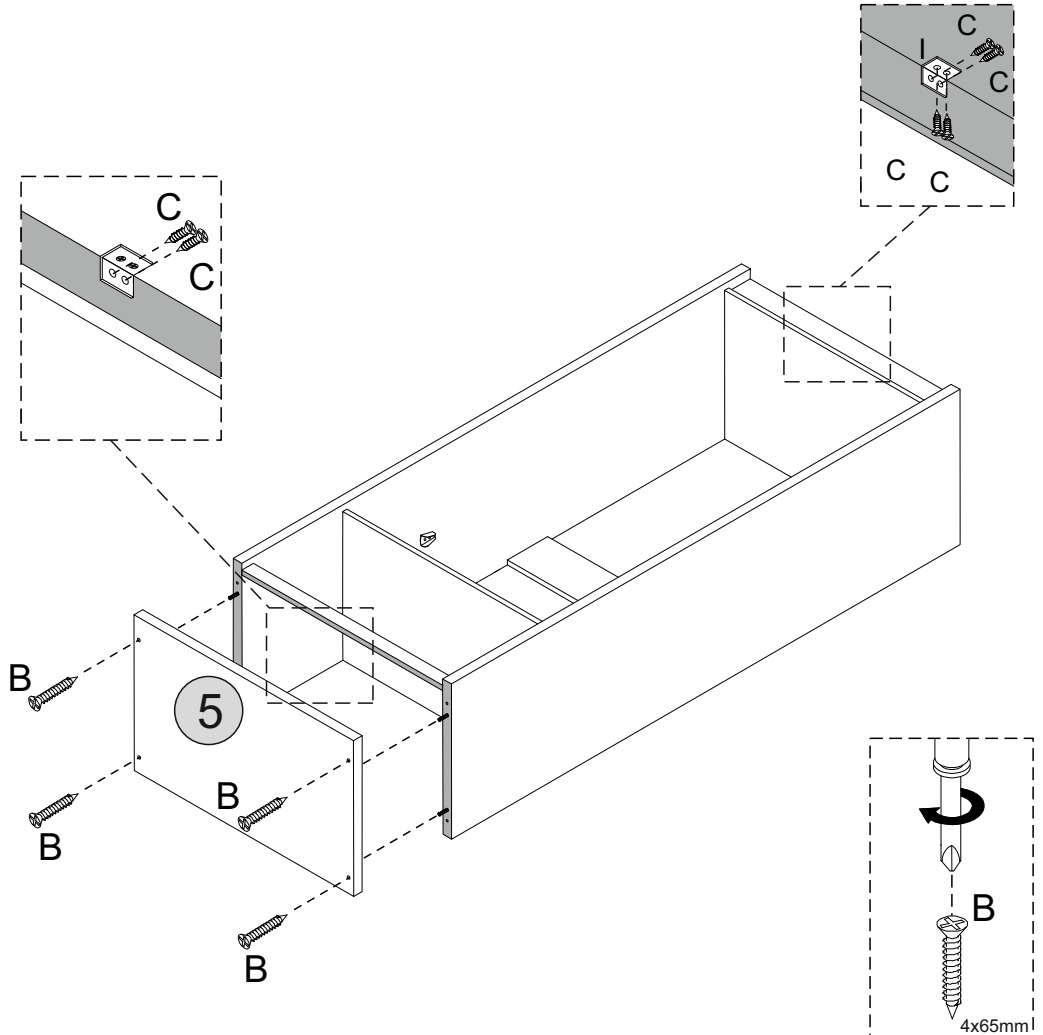
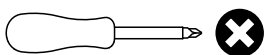

STEP 9

PARTS REQUIRED

11 - BACK PANEL x2

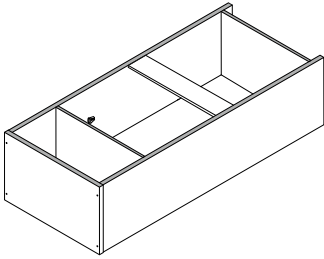

HARDWARE REQUIRED

C  02

K  58

TOOLS REQUIRED

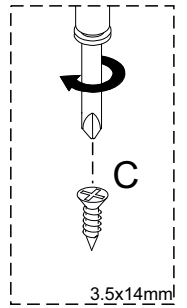
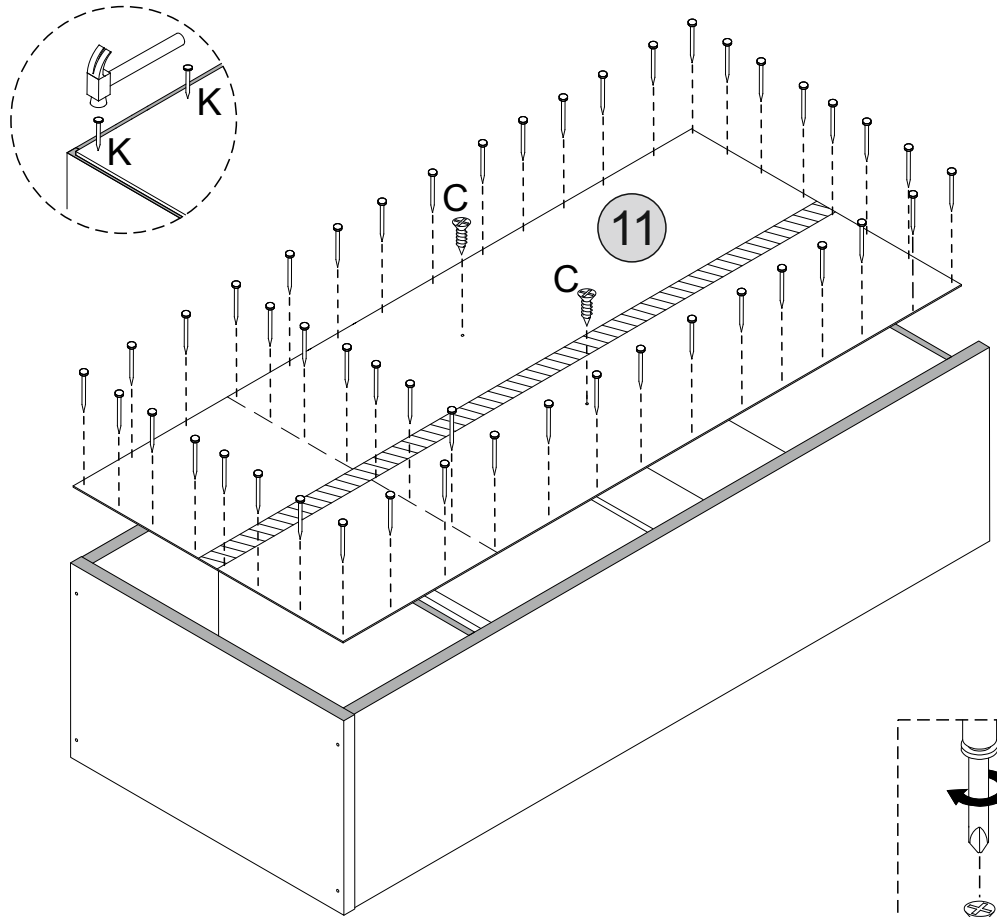
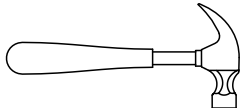
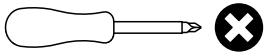

STEP 10

PARTS REQUIRED

3 - RIGHT DOOR PANEL x1

4 - LEFT DOOR PANEL x1

HARDWARE REQUIRED

C  12

E  06

TOOLS REQUIRED

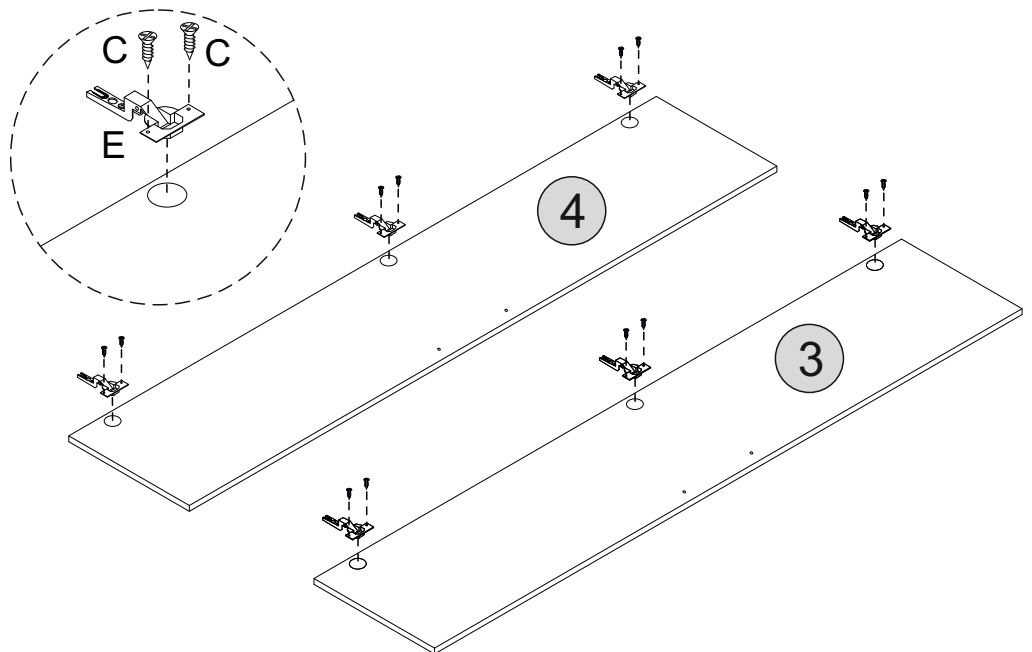
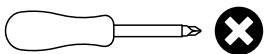

STEP 11

PARTS REQUIRED

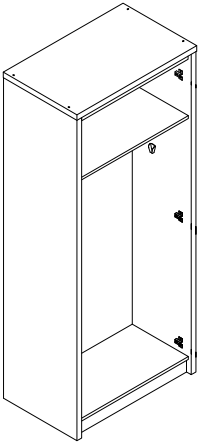

HARDWARE REQUIRED

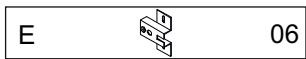
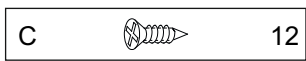

TOOLS REQUIRED

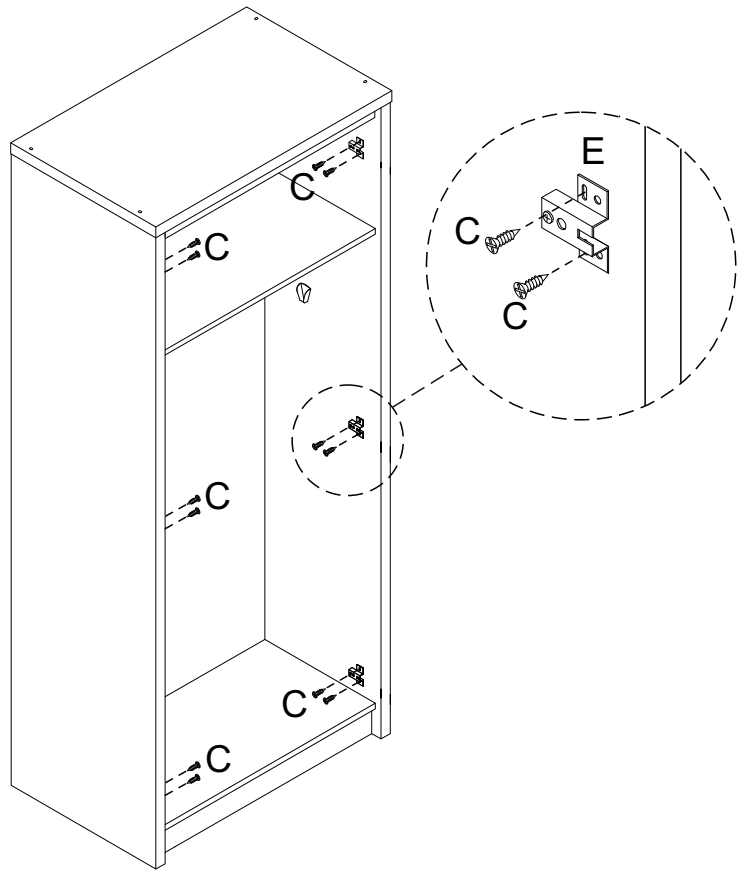
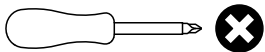

STEP 12

PARTS REQUIRED

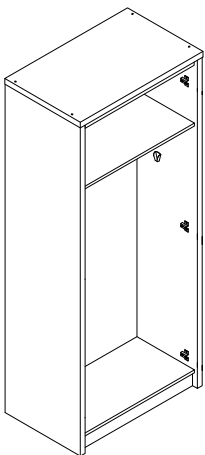
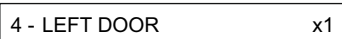
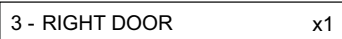

HARDWARE REQUIRED

TOOLS REQUIRED

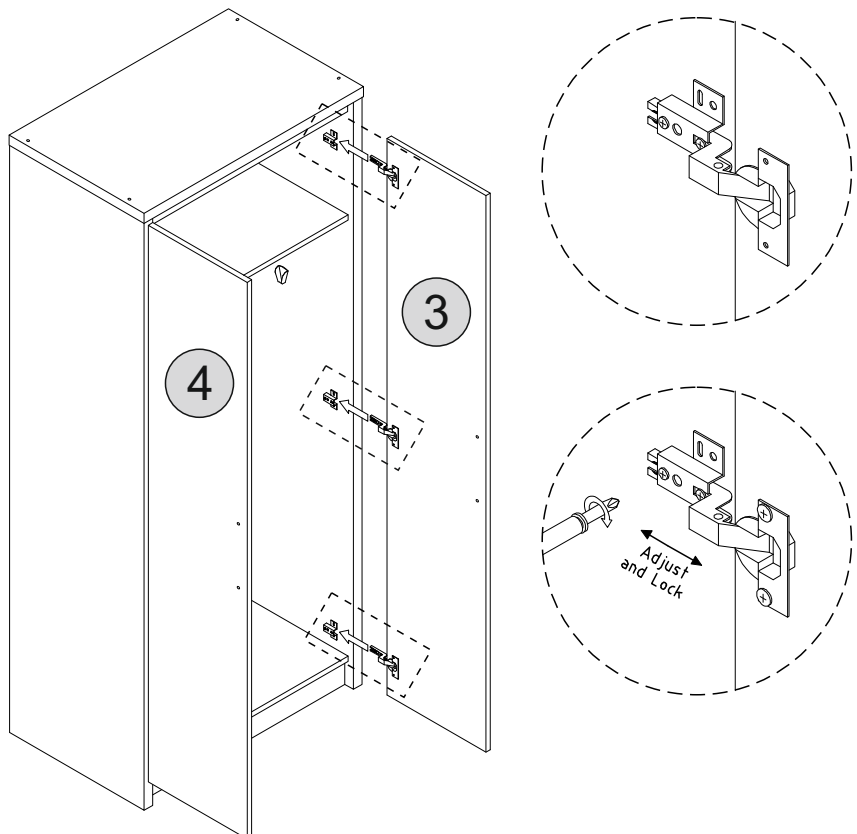
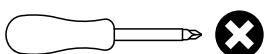

STEP 13

PARTS REQUIRED

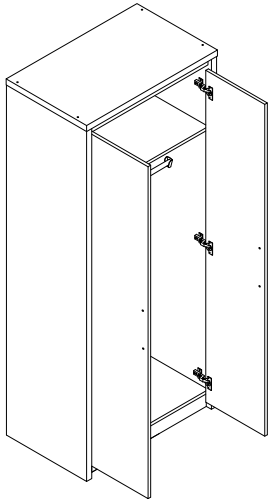

HARDWARE REQUIRED

| | | |
|---|--|----|
| D | | 01 |
| G | | 02 |
| H | | 04 |

TOOLS REQUIRED

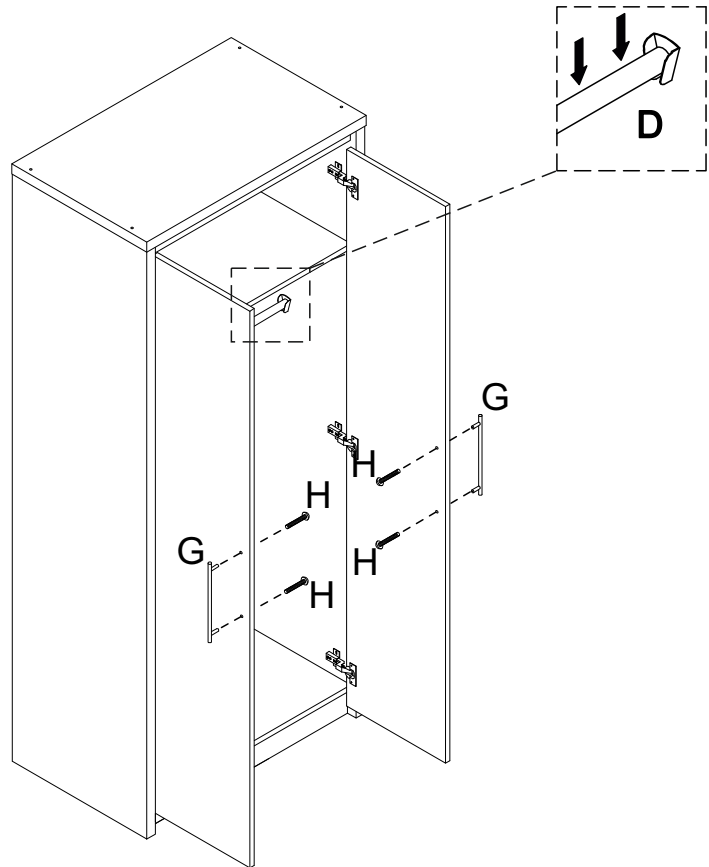
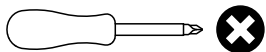

STEP 14

PARTS REQUIRED

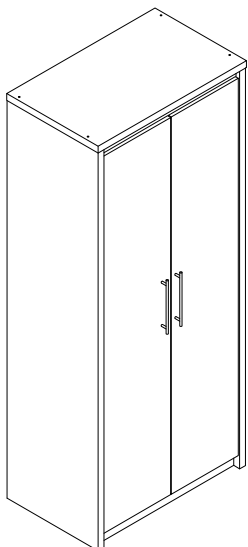

HARDWARE REQUIRED

| | | |
|---|--|----|
| H | | 01 |
|---|--|----|

TOOLS REQUIRED

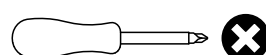

WARNING

Serious or fatal injuries can occur from furniture tipping over. To prevent the furniture from tipping over we recommend that it is permanently fixed to the wall.

Wall fixings are not supplied with this product as different wall materials require different types of fixing devices. Please make sure you use fixings suitable for the walls in your home.

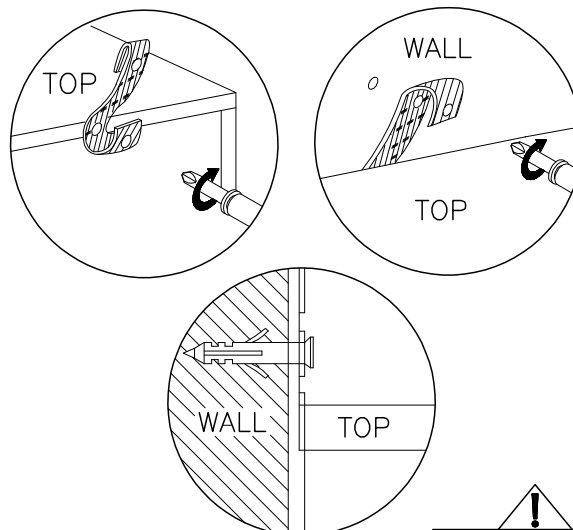

!
PLEASE NOTE THE CLEAR PROTECTIVE FILM WHICH NEEDS REMOVING FROM THE GLOSS FINISH.

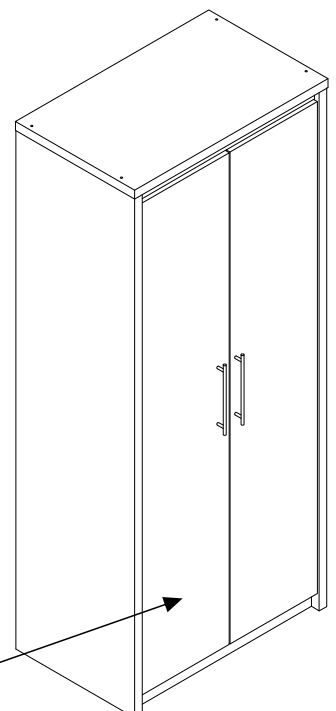

WHITE GLOSS SEVILLE 3 DRAWER CHEST ASSEMBLY INSTRUCTIONS

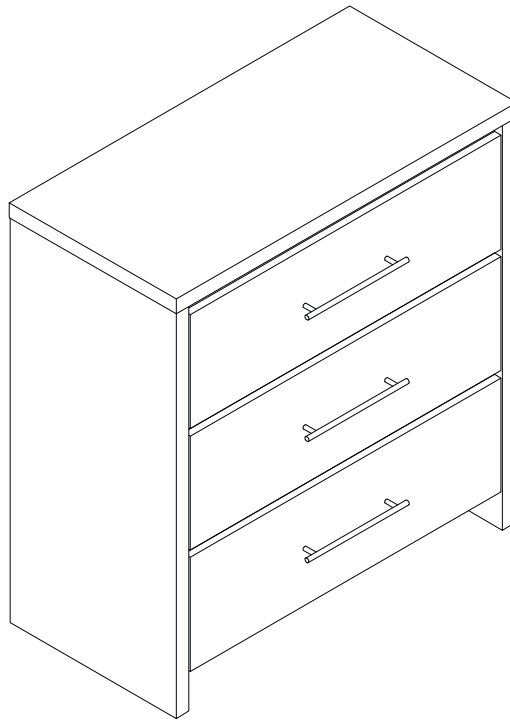

**FOR DOMESTIC USE ONLY
IMPORTANT**

PLEASE READ BEFORE YOU CONTINUE FURTHER

THE PRODUCT YOU HAVE PURCHASED WILL GIVE YOU MANY YEARS OF SERVICE IF YOU FOLLOW THE GUIDELINES FOR ITS SAFE ASSEMBLY AND PERIODIC MAINTENANCE AND CLEANING.

ASSEMBLE ON A SOFT CLEAN SURFACE.

DO NOT USE ANY TOOLS OTHER THAN THOSE SHOWN.

ANY SPANNERS OR ALLEN KEYS REQUIRED ARE INCLUDED WITH THE FITTING KIT.

DO NOT FOR ANY REASON USE A POWER TOOL TO ASSEMBLE THIS PRODUCT. ITS USE WILL INVALIDATE ANY CLAIM YOU MAY HAVE AND COULD MAKE THIS PRODUCT UNSAFE.

DEPENDING ON THE AMOUNT OF USE THIS PRODUCT RECEIVES, IT MAY BE NECESSARY TO TIGHTEN UP THE FIXINGS FROM TIME TO TIME. THIS IS COMPLETELY NORMAL FOR ANY FLAT PACK FURNITURE. DO NOT OVERTIGHTEN FIXINGS.

FOR CLEANING, YOU MAY USE A DAMP CLOTH (NOT WET). DO NOT USE POLISH, DETERGENT OR CHEMICAL CLEANERS.



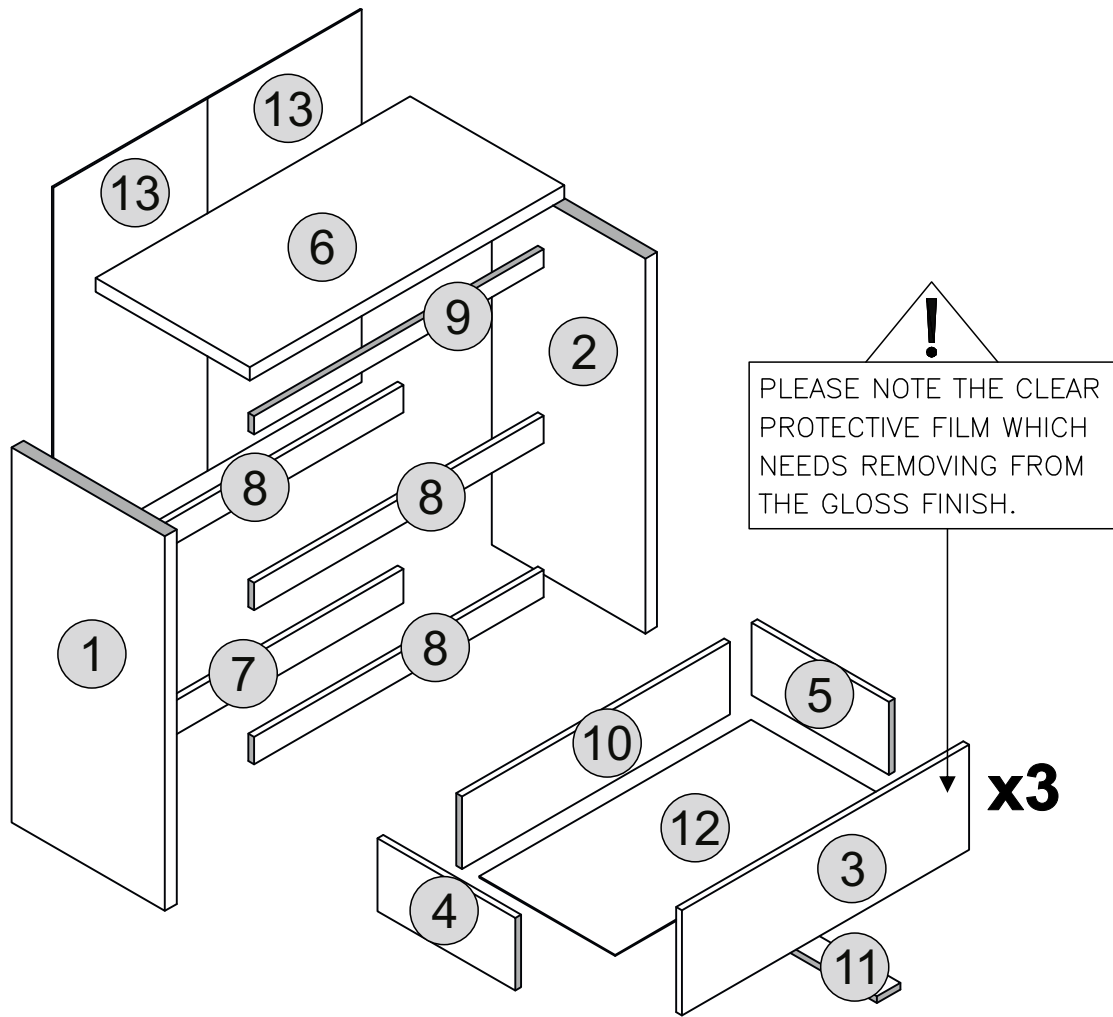







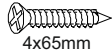

THIS SURFACE OF THIS ITEM IS NOT HEAT RESISTANT. ALWAYS USE A PLACE MAT UNDER HOT OR COLD ITEMS TO PREVENT MARKING.



PART LIST

| Part Number | Part Code | Part Description | Quantity | Carton |
|-------------|---------------------|-------------------|----------|--------|
| 1 | S100-102-051-ZF1-01 | Left Side Panel | 1 | 1/1 |
| 2 | S100-102-051-ZF1-02 | Right Side Panel | 1 | 1/1 |
| 3 | S100-102-051-ZF1-03 | Drawer Front | 3 | 1/1 |
| 4 | S100-102-051-ZF1-04 | Left Drawer Side | 3 | 1/1 |
| 5 | S100-102-051-ZF1-05 | Right Drawer Side | 3 | 1/1 |
| 6 | S100-102-051-ZF1-06 | Top Panel | 1 | 1/1 |
| 7 | S100-102-051-ZF1-07 | Crossbar Back | 1 | 1/1 |
| 8 | S100-102-051-ZF1-08 | Support | 3 | 1/1 |
| 9 | S100-102-051-ZF1-09 | Support Panel | 1 | 1/1 |
| 10 | S100-102-051-ZF1-10 | Drawer Back | 3 | 1/1 |
| 11 | S100-102-051-ZF1-11 | Drawer Support | 3 | 1/1 |
| 12 | S100-102-051-ZF1-12 | Drawer Base | 3 | 1/1 |
| 13 | S100-102-051-ZF1-13 | Back Panel | 2 | 1/1 |

HARDWARE LIST

| No. | Part Name | | Qty |
|-----|----------------------------|---|-----|
| A | Wooden Dowel (6x25mm) |  | x22 |
| B | 65mm Screw (4x65mm) |  | x8 |
| C | 14mm Screw (3.5x14mm) |  | x30 |
| D | 38mm Screw (4x38mm) |  | x15 |
| E | Cam Bolt (8032T) |  | x13 |
| F | Cam Nut (1512) |  | x13 |
| G | 10" Handle (192mm) |  | x3 |
| H | 20mm Handle Screw |  | x6 |
| I | 14" Drawer Slide |  | x3 |
| J | PVC L - Bracket |  | x1 |
| K | Plastic Foot |  | x5 |
| L | 6/8" Nail |  | x40 |
| M | Wall Fixation (4x20mm=1pc) |  | x1 |
| N | Screw Cover (Sticker 12mm) |  | x8 |

TIPS FOR FITTINGS CAM-LOCKS

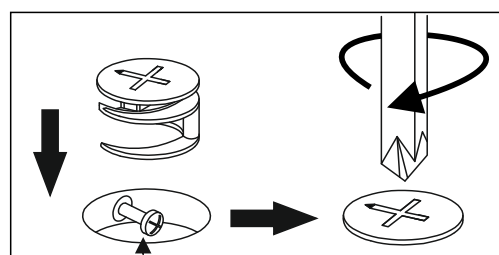
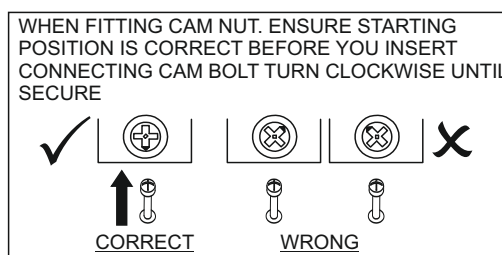

Cam bolt head needs to be in centre

CAMBOLT

Tighten until shoulder in flush with panel. Do not overtighten or undertighten (see example below)

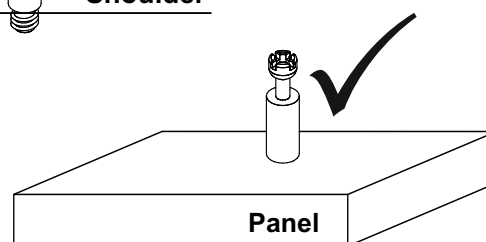
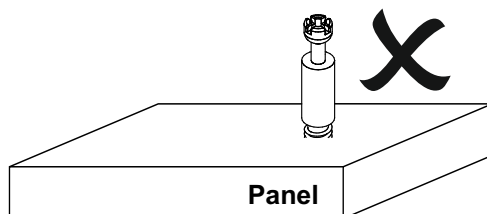
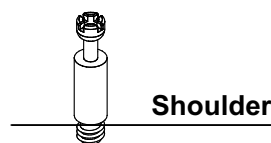

STEP 1

PARTS REQUIRED

1 - LEFT SIDE PANEL x1

2 - RIGHT SIDE PANEL x1

HARDWARE REQUIRED

C  3.5x14mm 12

I  03

K  04

TOOLS REQUIRED

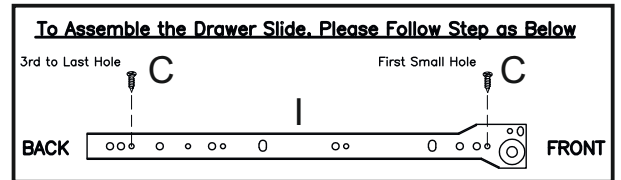
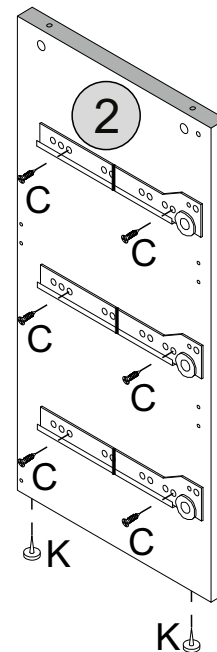
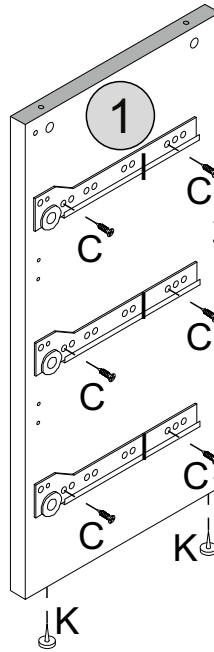
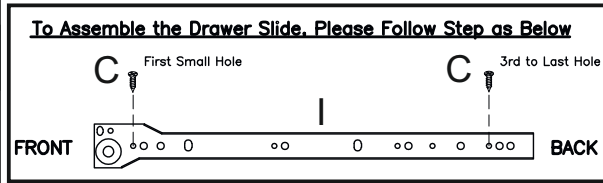
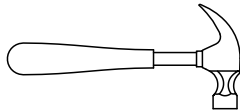
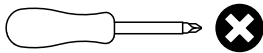

STEP 2

PARTS REQUIRED

7 - CROSSBAR BACK x1

8 - SUPPORT x3

9 - SUPPORT PANEL x1

HARDWARE REQUIRED

A  10

TOOLS REQUIRED

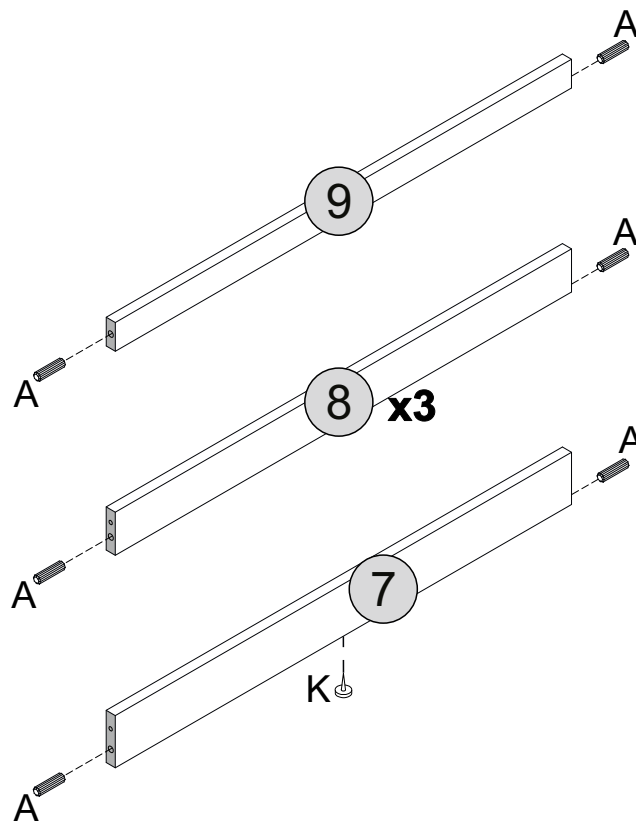
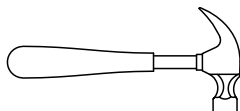

STEP 3

PARTS REQUIRED

| | |
|----------------------|----|
| 1 - LEFT SIDE PANEL | x1 |
| 2 - RIGHT SIDE PANEL | x1 |
| 7 - CROSSBAR BACK | x1 |
| 8 - SUPPORT | x3 |
| 9 - SUPPORT PANEL | x1 |

HARDWARE REQUIRED

| | | |
|---|---|----|
| B |  | 08 |
|---|---|----|

TOOLS REQUIRED

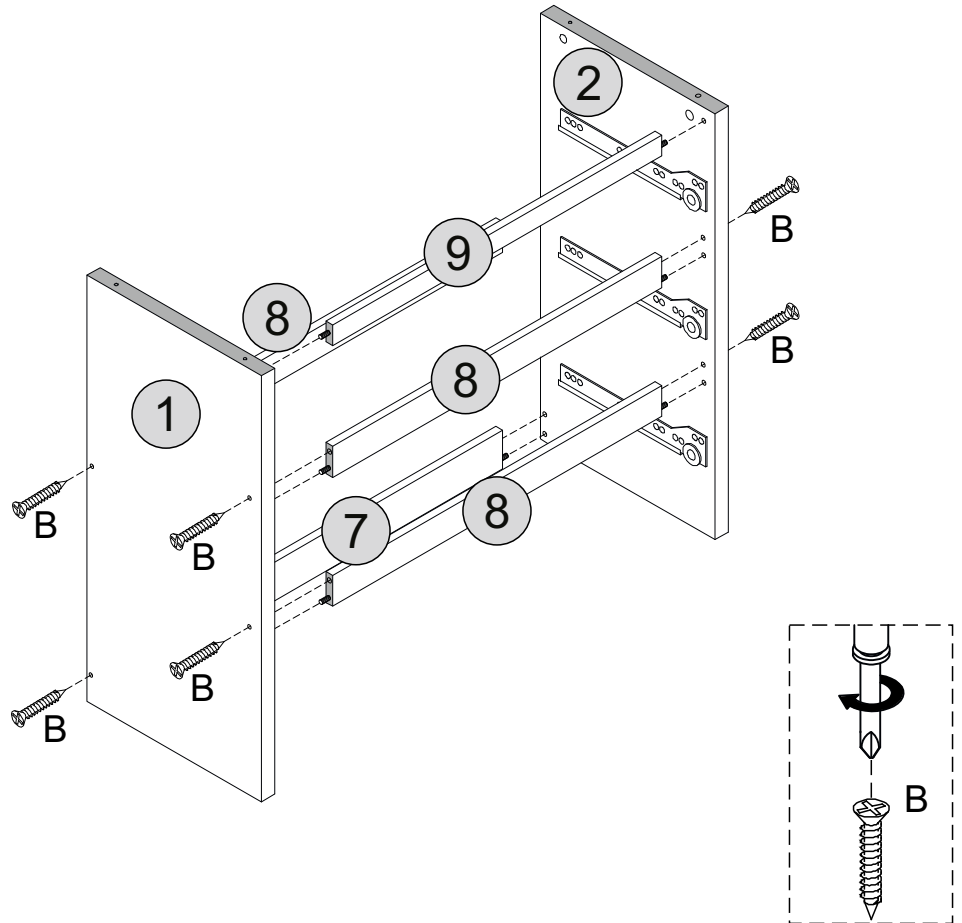
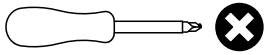

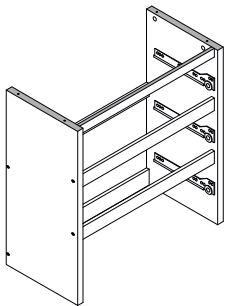

STEP 4

PARTS REQUIRED



HARDWARE REQUIRED

| | | |
|---|---|----|
| F |  | 04 |
|---|---|----|

| | | |
|---|---|----|
| N |  | 08 |
|---|---|----|

TOOLS REQUIRED

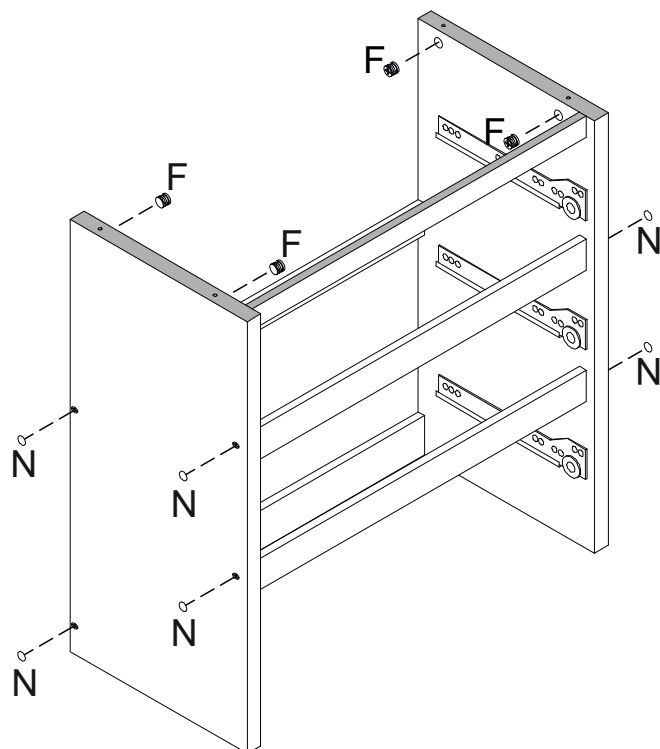

STEP 5

PARTS REQUIRED

6 - TOP PANEL x1

HARDWARE REQUIRED

C  02
3.5x14mm

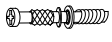
E  04

J  01

TOOLS REQUIRED

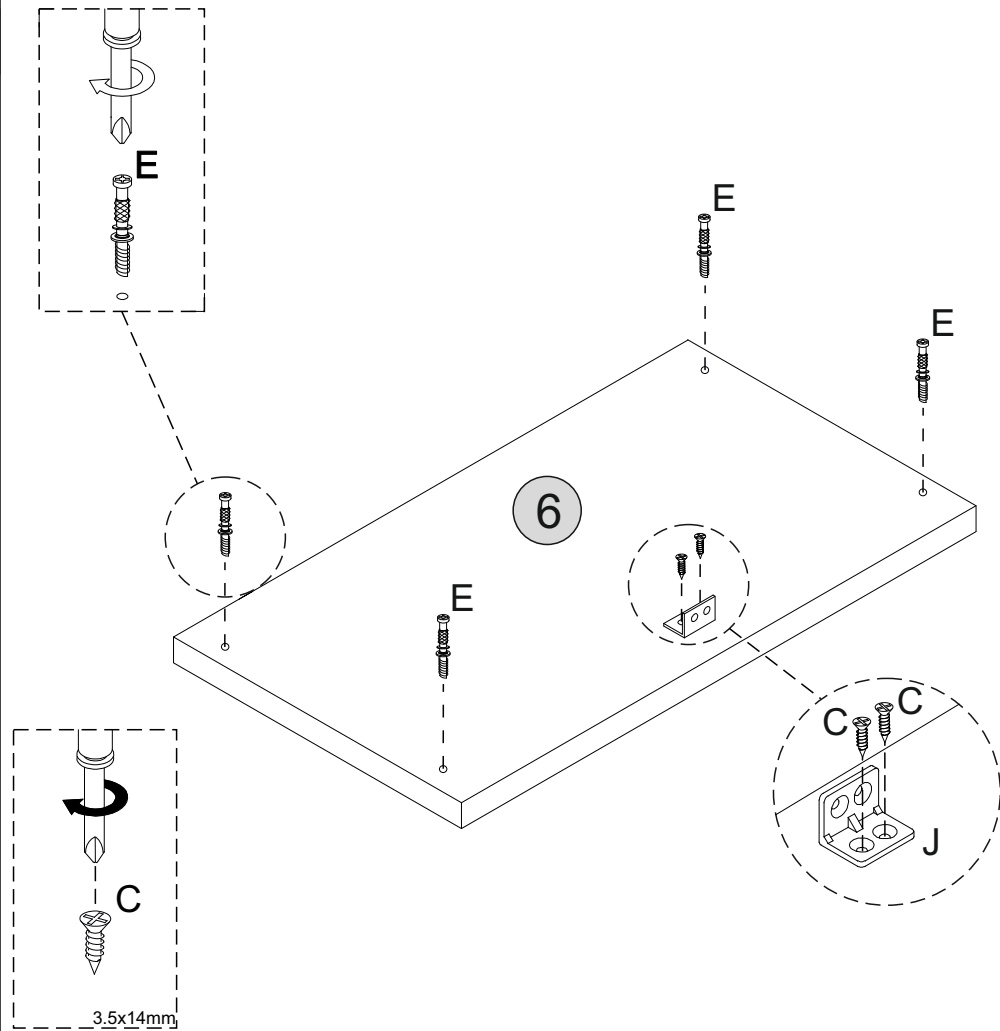
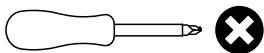

STEP 6

PARTS REQUIRED

6 - TOP PANEL x1

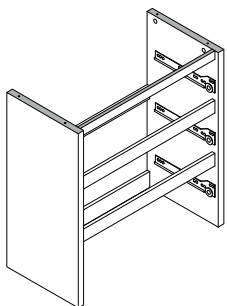

HARDWARE REQUIRED

C  02
3.5x14mm

TOOLS REQUIRED

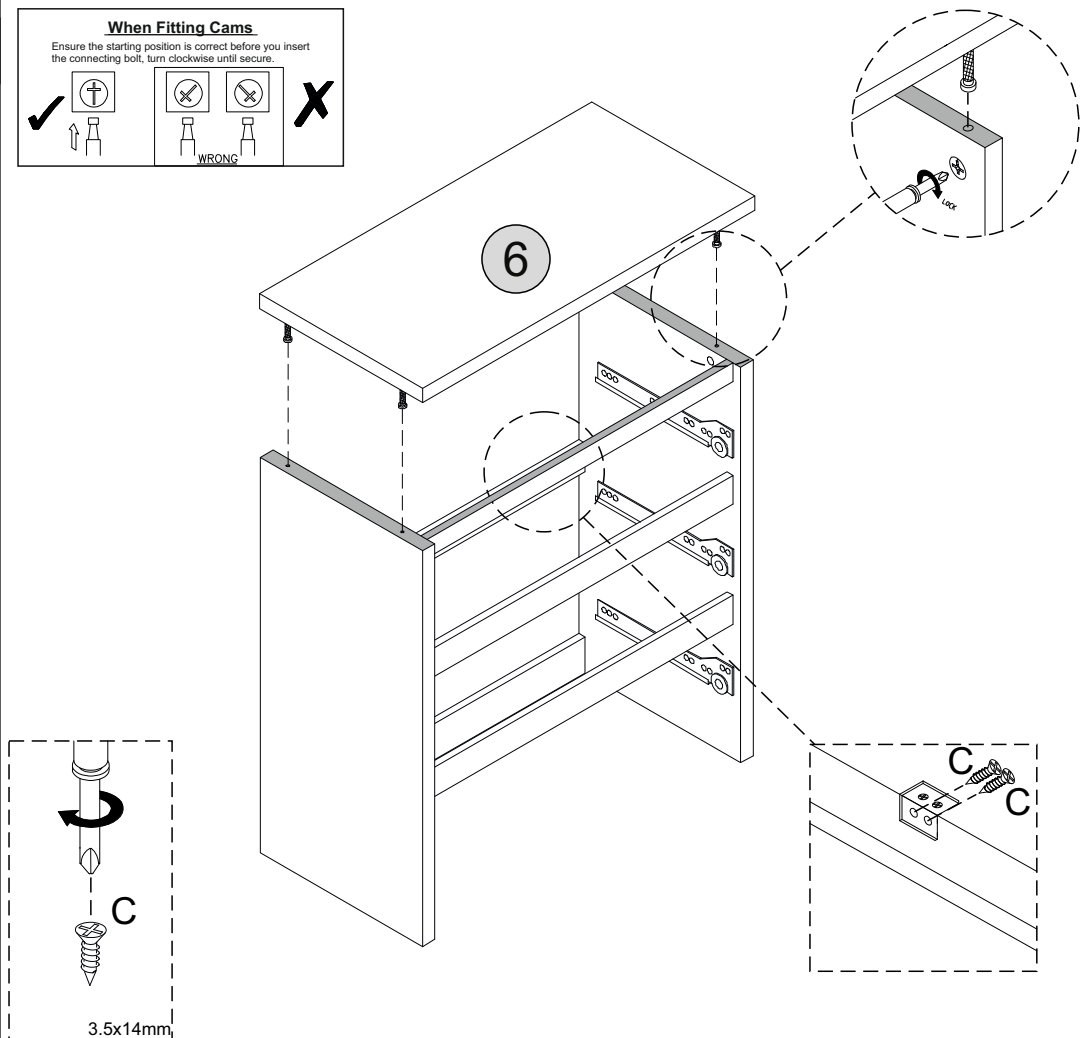
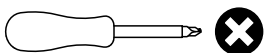

STEP 7

PARTS REQUIRED

13 - BACK PANEL x1

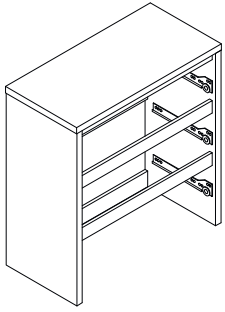

HARDWARE REQUIRED

C  02
3.5x14mm

L  40

TOOLS REQUIRED

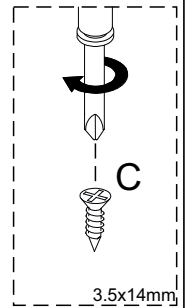
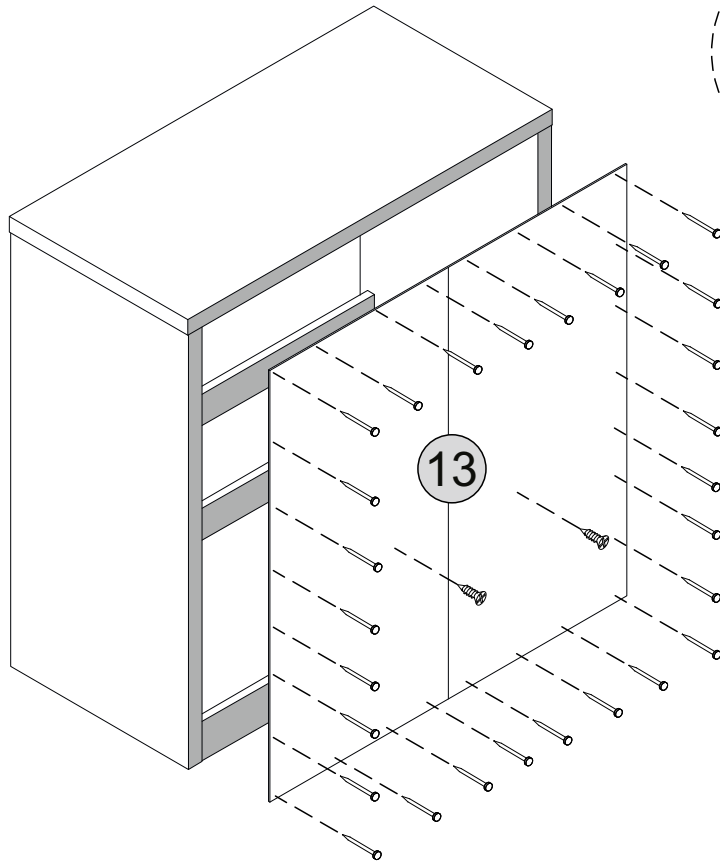
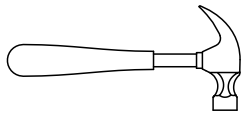
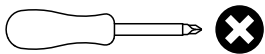

STEP 8

PARTS REQUIRED

3 - DRAWER FRONT x3

4 - LEFT DRAWER SIDE x3

5 - RIGHT DRAWER SIDE x3

11 - DRAWER SUPPORT x3

HARDWARE REQUIRED

A  12

E  09

F  09

TOOLS REQUIRED

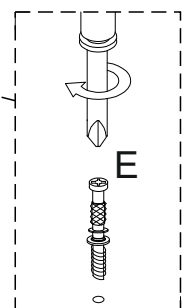
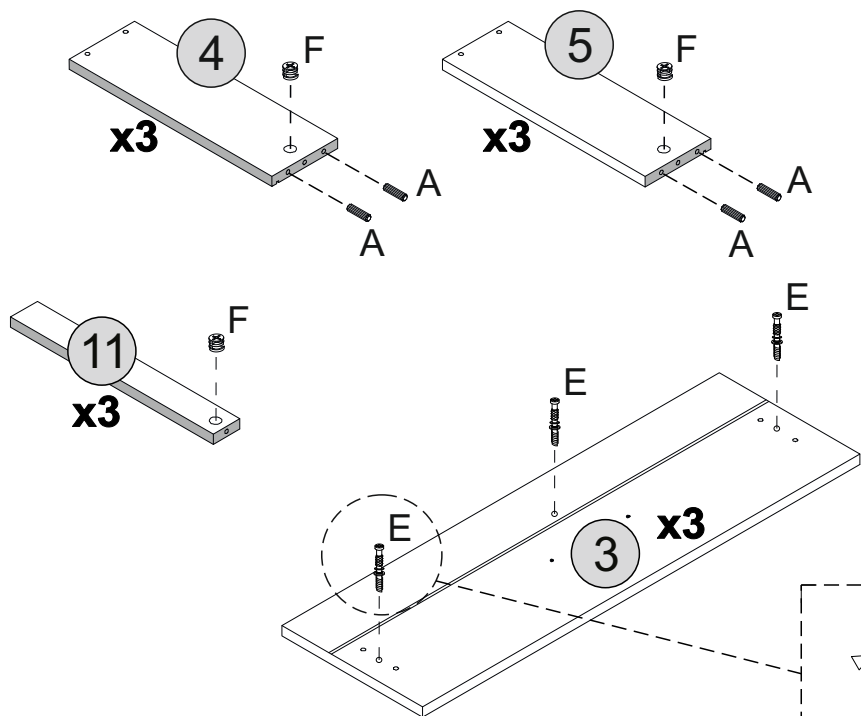
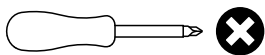

STEP 9

PARTS REQUIRED

4 - LEFT DRAWER SIDE x3

5 - RIGHT DRAWER SIDE x3

10 - DRAWER BACK x3

11 - DRAWER SUPPORT x3

HARDWARE REQUIRED

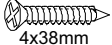
D  15

TOOLS REQUIRED

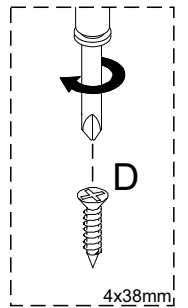
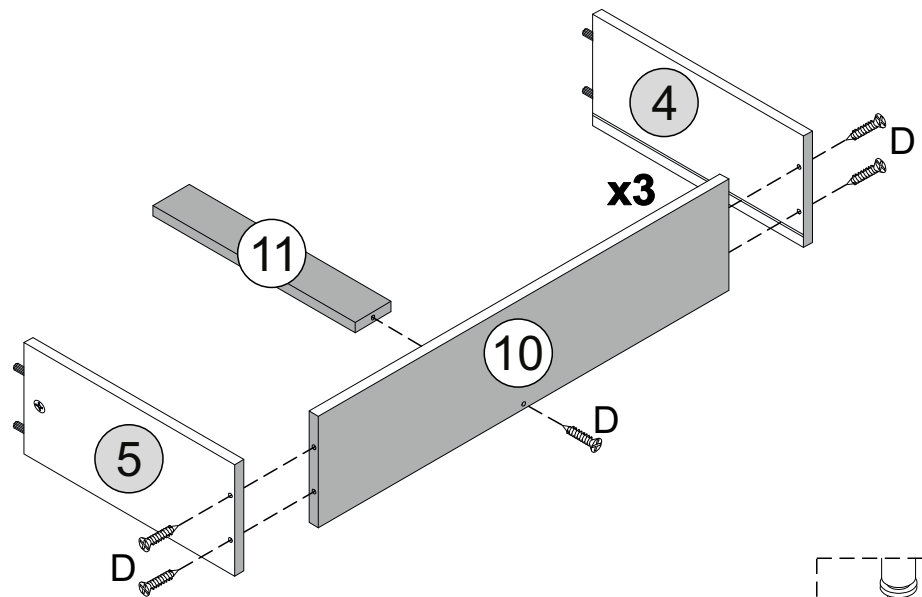
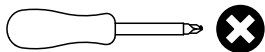

STEP 10

PARTS REQUIRED

12 - DRAWER BASE x3

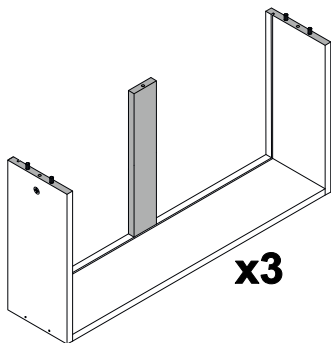

HARDWARE REQUIRED

TOOLS REQUIRED

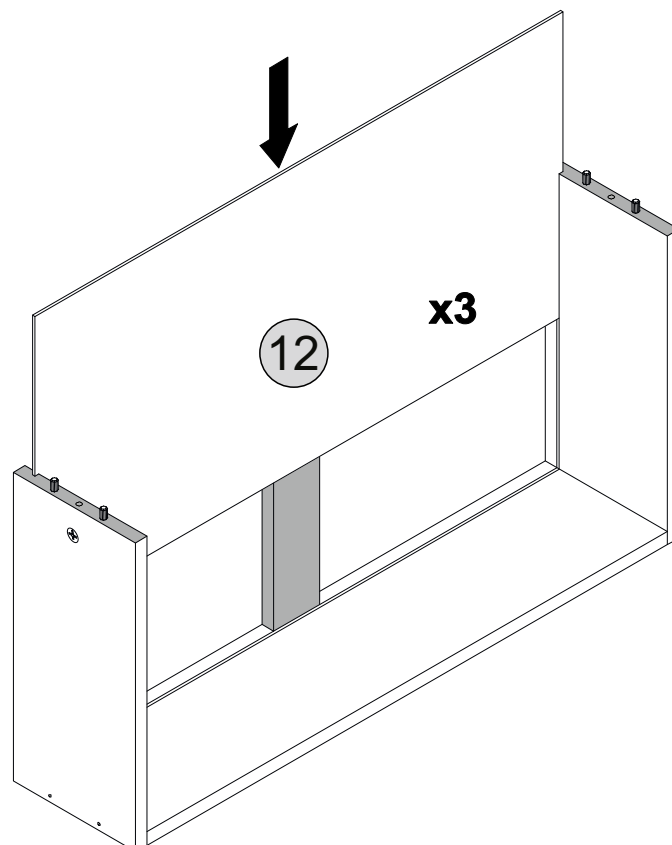

STEP 11

PARTS REQUIRED

3 - DRAWER FRONT x3

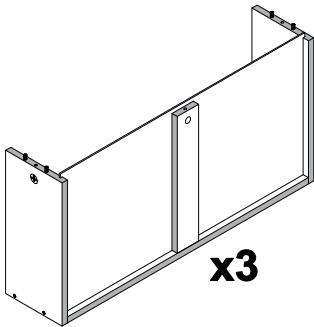

HARDWARE REQUIRED

TOOLS REQUIRED

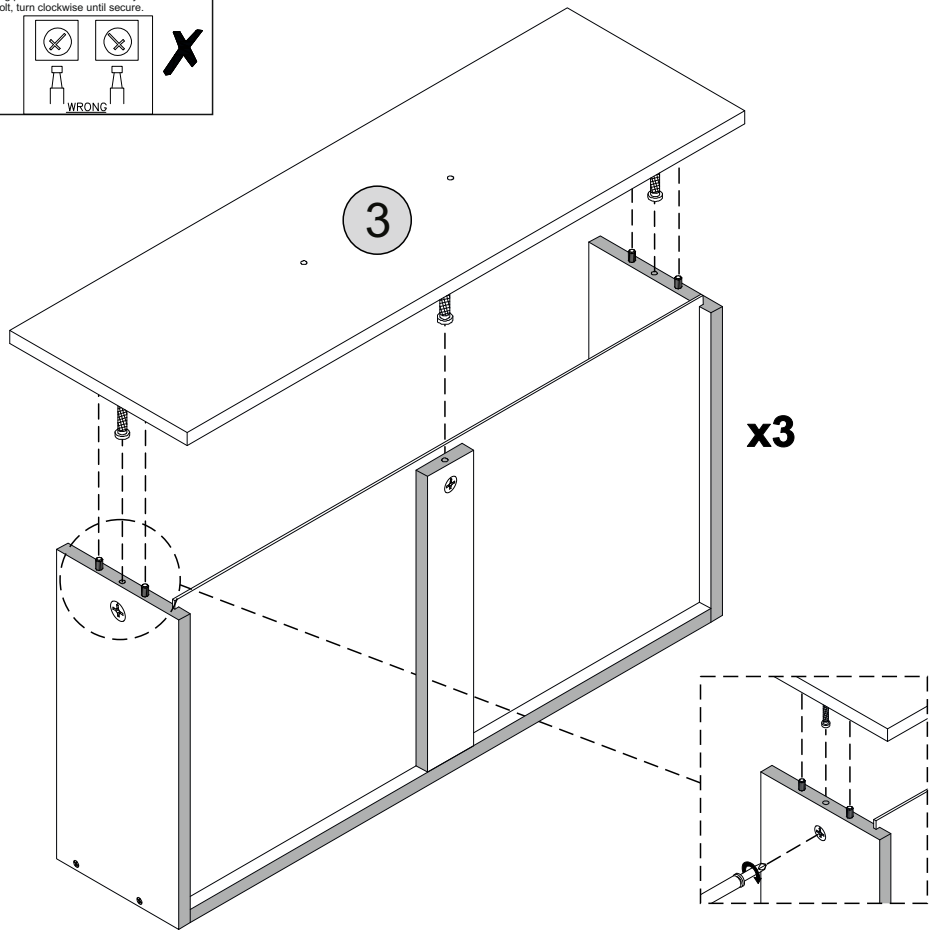
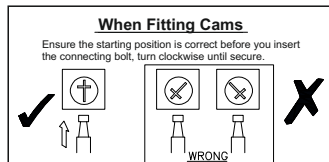
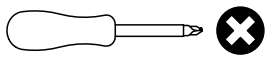

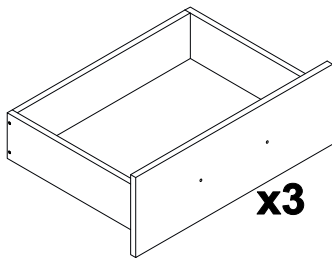

STEP 12

PARTS REQUIRED



HARDWARE REQUIRED

G  03

H  06

TOOLS REQUIRED

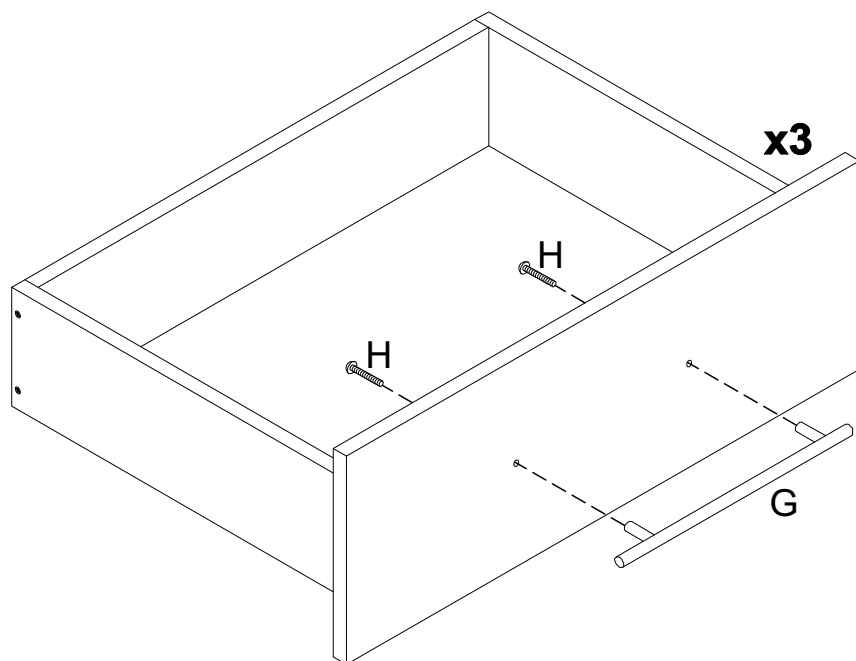
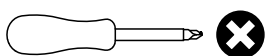

STEP 13

PARTS REQUIRED

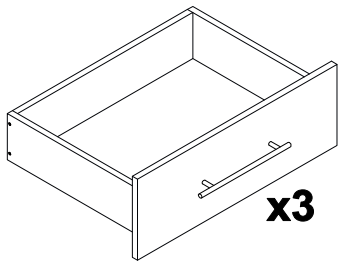

HARDWARE REQUIRED

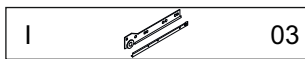
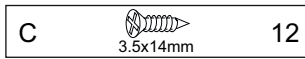

TOOLS REQUIRED

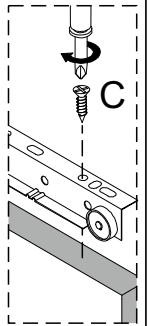
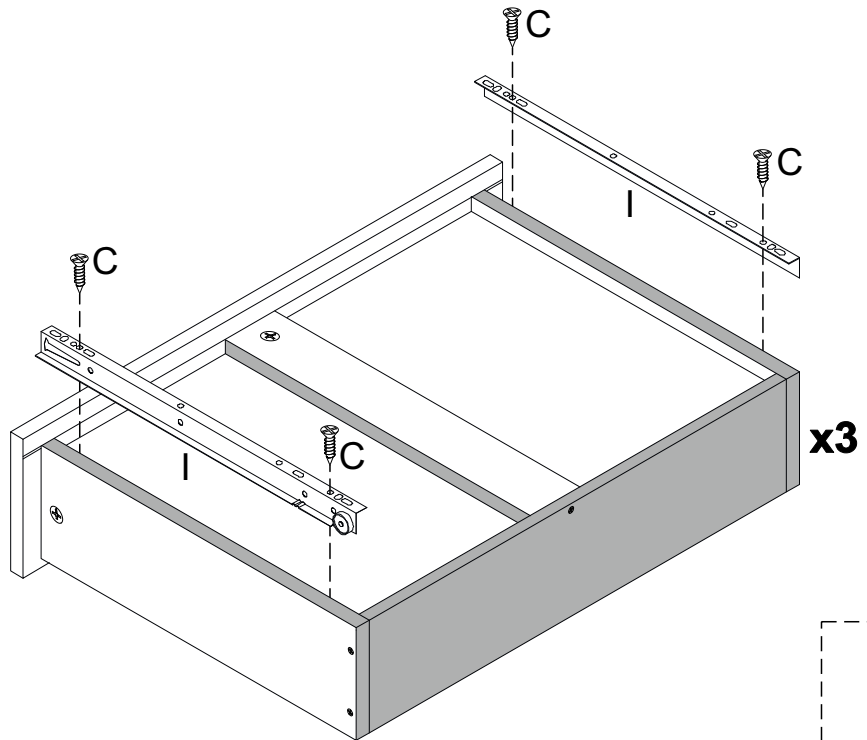
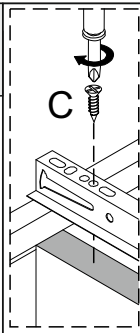
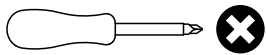

STEP 14

PARTS REQUIRED

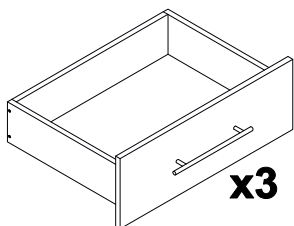
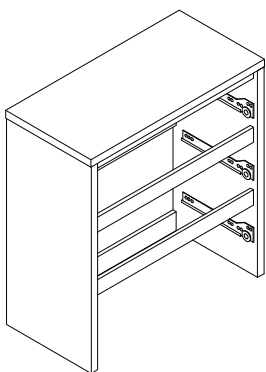

HARDWARE REQUIRED

TOOLS REQUIRED

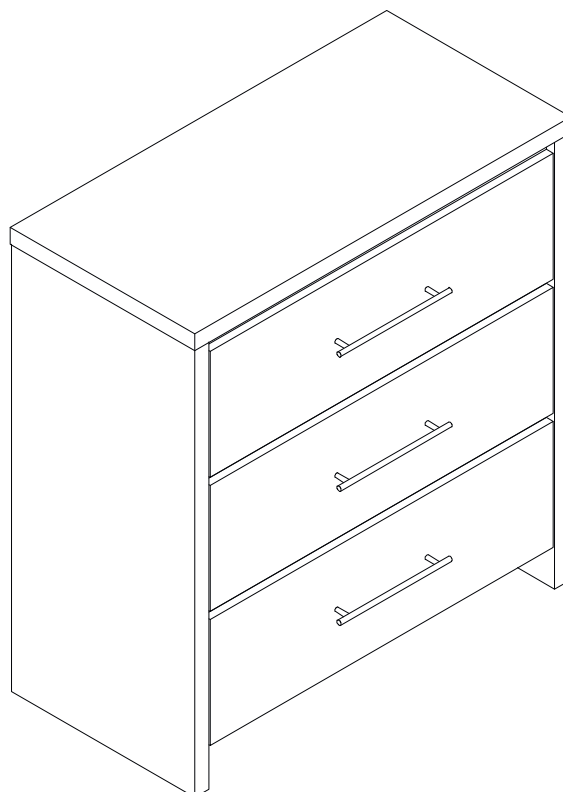

!
PLEASE NOTE THE CLEAR PROTECTIVE FILM WHICH NEEDS REMOVING FROM THE GLOSS FINISH.

STEP 15

PARTS REQUIRED

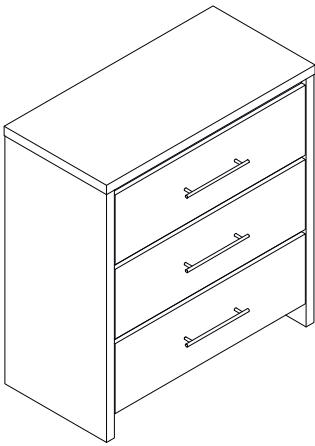

HARDWARE REQUIRED

K  01

TOOLS REQUIRED

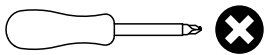

WARNING

Serious or fatal injuries can occur from furniture tipping over. To prevent the furniture from tipping over we recommend that it is permanently fixed to the wall.

Wall fixings are not supplied with this product as different wall materials require different types of fixing devices. Please make sure you use fixings suitable for the walls in your home.

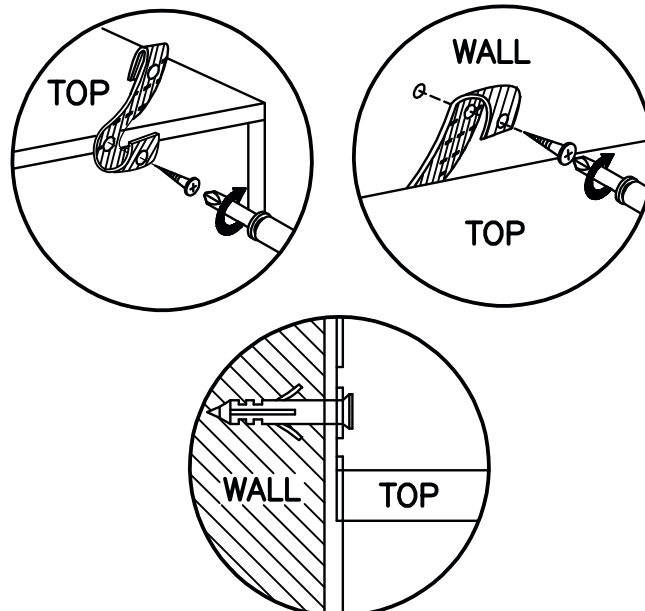
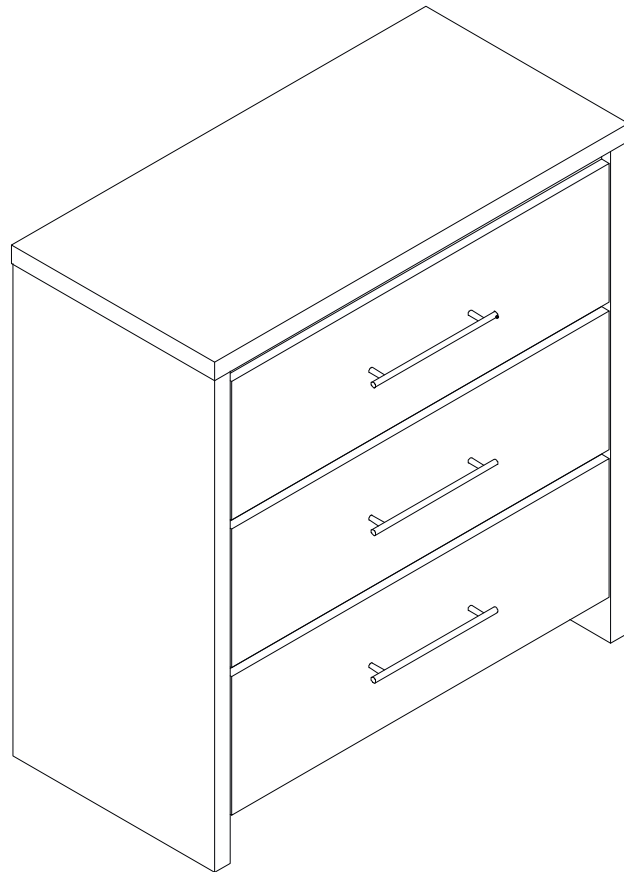

WHITE GLOSS SEVILLE 1 DRAWER BEDSIDE ASSEMBLY INSTRUCTIONS

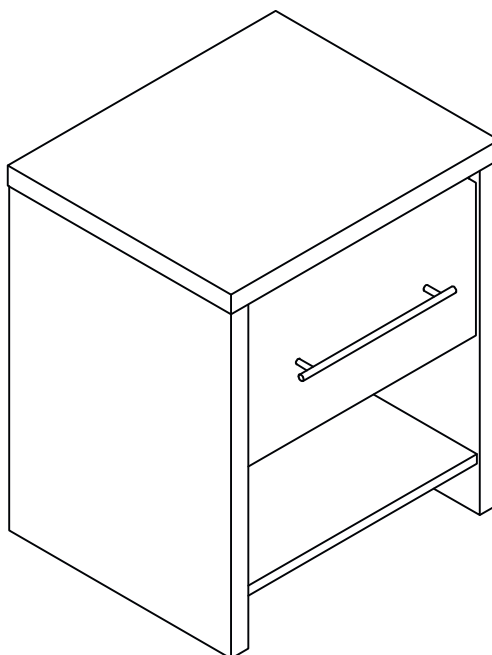

FOR DOMESTIC USE ONLY
IMPORTANT

PLEASE READ BEFORE YOU CONTINUE FURTHER

THE PRODUCT YOU HAVE PURCHASED WILL GIVE YOU MANY YEARS OF SERVICE IF YOU FOLLOW THE GUIDELINES FOR ITS SAFE ASSEMBLY AND PERIODIC MAINTENANCE AND CLEANING.

ASSEMBLE ON A SOFT CLEAN SURFACE.

DO NOT USE ANY TOOLS OTHER THAN THOSE SHOWN.

ANY SPANNERS OR ALLEN KEYS REQUIRED ARE INCLUDED WITH THE FITTING KIT.

DO NOT FOR ANY REASON USE A POWER TOOL TO ASSEMBLE THIS PRODUCT. ITS USE WILL INVALIDATE ANY CLAIM YOU MAY HAVE AND COULD MAKE THIS PRODUCT UNSAFE.

DEPENDING ON THE AMOUNT OF USE THIS PRODUCT RECEIVES, IT MAY BE NECESSARY TO TIGHTEN UP THE FIXINGS FROM TIME TO TIME. THIS IS COMPLETELY NORMAL FOR ANY FLAT PACK FURNITURE. DO NOT OVERTIGHTEN FIXINGS.

FOR CLEANING, YOU MAY USE A DAMP CLOTH (NOT WET). DO NOT USE POLISH, DETERGENT OR CHEMICAL CLEANERS.



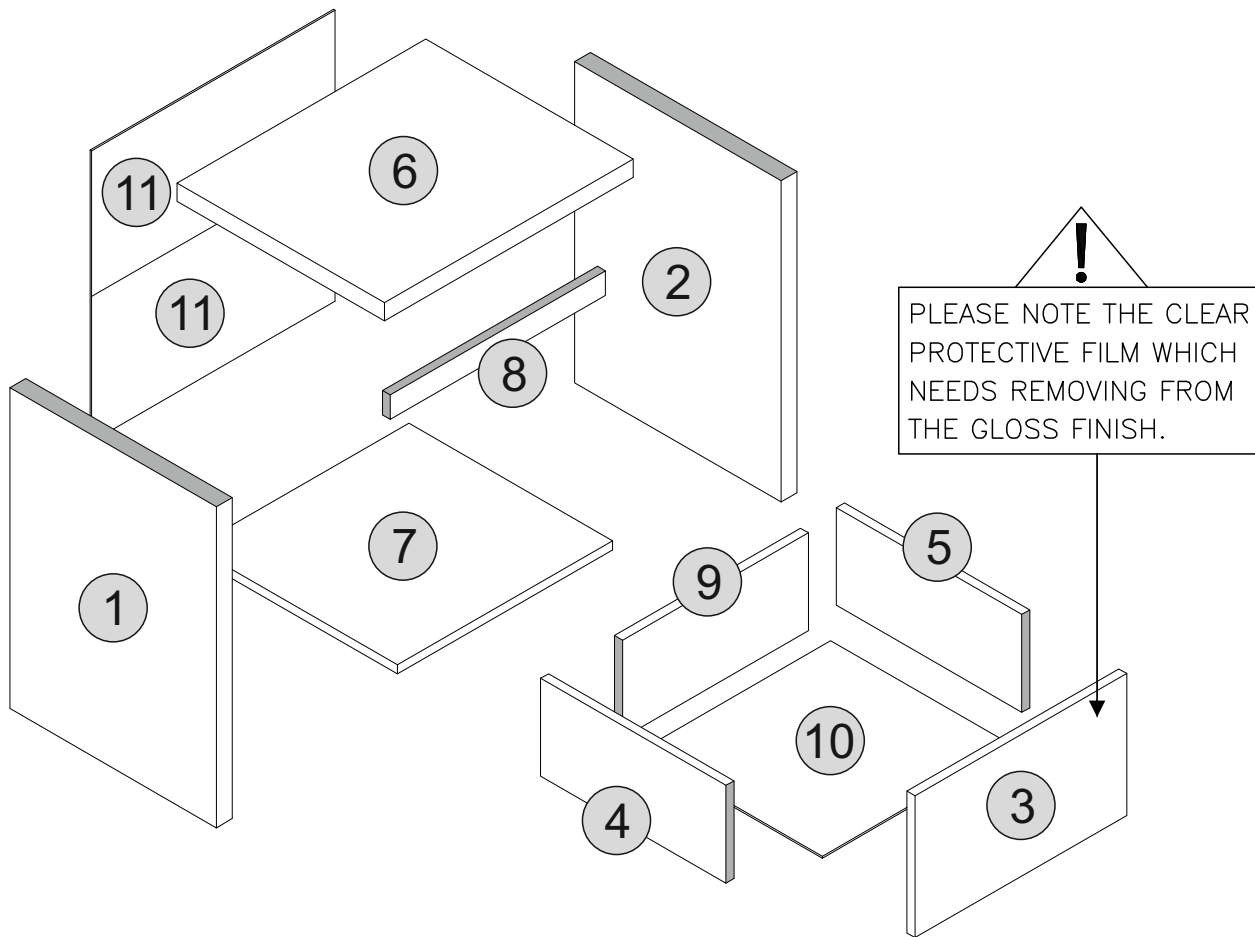









THIS SURFACE OF THIS ITEM IS NOT HEAT RESISTANT. ALWAYS USE A PLACE MAT UNDER HOT OR COLD ITEMS TO PREVENT MARKING.



PART LIST

| Part Number | Part Code | Part Description | Quantity | Carton |
|-------------|---------------------|-------------------|----------|--------|
| 1 | S100-103-027-ZF1-01 | Left Side Panel | 1 | 1/1 |
| 2 | S100-103-027-ZF1-02 | Right Side Panel | 1 | 1/1 |
| 3 | S100-103-027-ZF1-03 | Drawer Front | 1 | 1/1 |
| 4 | S100-103-027-ZF1-04 | Left Drawer Side | 1 | 1/1 |
| 5 | S100-103-027-ZF1-05 | Right Drawer Side | 1 | 1/1 |
| 6 | S100-103-027-ZF1-06 | Top Panel | 1 | 1/1 |
| 7 | S100-103-027-ZF1-07 | Bottom Panel | 1 | 1/1 |
| 8 | S100-103-027-ZF1-08 | Support Panel | 1 | 1/1 |
| 9 | S100-103-027-ZF1-09 | Drawer Back | 1 | 1/1 |
| 10 | S100-103-027-ZF1-10 | Drawer Base | 1 | 1/1 |
| 11 | S100-103-027-ZF1-11 | Back Panel | 2 | 1/1 |

HARDWARE LIST

| No. | Part Name | | Qty |
|-----|----------------------------|---|-----|
| A | Wooden Dowel (6x25mm) |  | x10 |
| B | 65mm Screw (4x65mm) |  | x4 |
| C | 14mm Screw (3.5x14mm) |  | x12 |
| D | 38mm Screw (4x38mm) |  | x4 |
| E | Cam Bolt (8032T) |  | x6 |
| F | Cam Nut (1512) |  | x6 |
| G | 10" Handle (192mm) |  | x1 |
| H | 20mm Handle Screw |  | x1 |
| I | 14" Drawer Slide |  | x1 |
| J | PVC L - Bracket |  | x1 |
| K | Plastic Foot |  | x4 |
| L | 6/8" Nail |  | x24 |
| M | Screw Cover (Sticker 12mm) |  | x4 |

TIPS FOR FITTINGS CAM-LOCKS

WHEN FITTING CAM NUT. ENSURE STARTING POSITION IS CORRECT BEFORE YOU INSERT. CONNECTING CAM BOLT TURN CLOCKWISE UNTIL SECURE

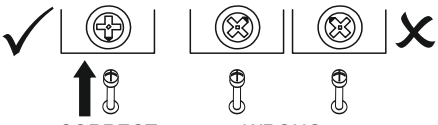

CORRECT **WRONG**

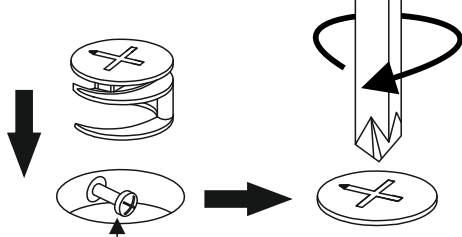

Cam bolt head needs to be in centre

CAMBOLT

Tighten until shoulder in flush with panel. Do not overtighten or undertighten (see example below)

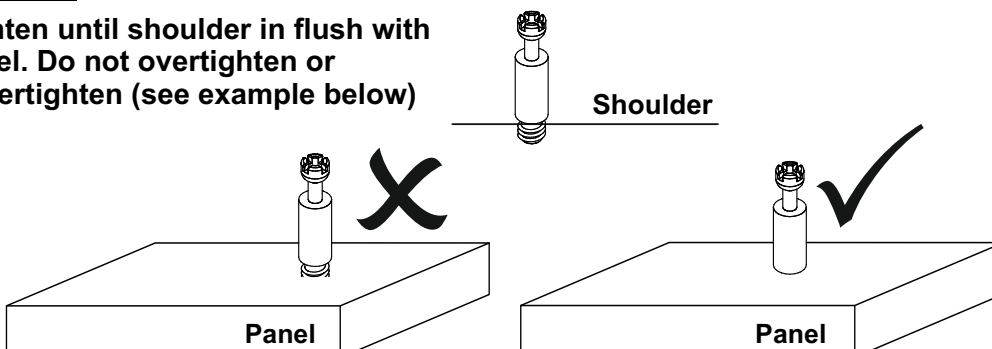

Shoulder

Panel **Panel**

STEP 1

PARTS REQUIRED

1 - LEFT SIDE PANEL x1

2 - RIGHT SIDE PANEL x1

HARDWARE REQUIRED

C  04
3.5x14mm

I  01

K  04

TOOLS REQUIRED

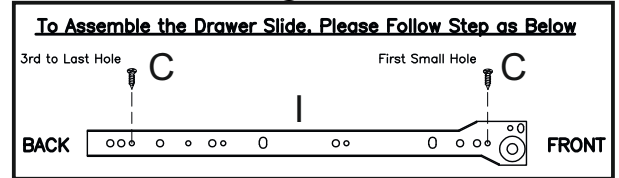
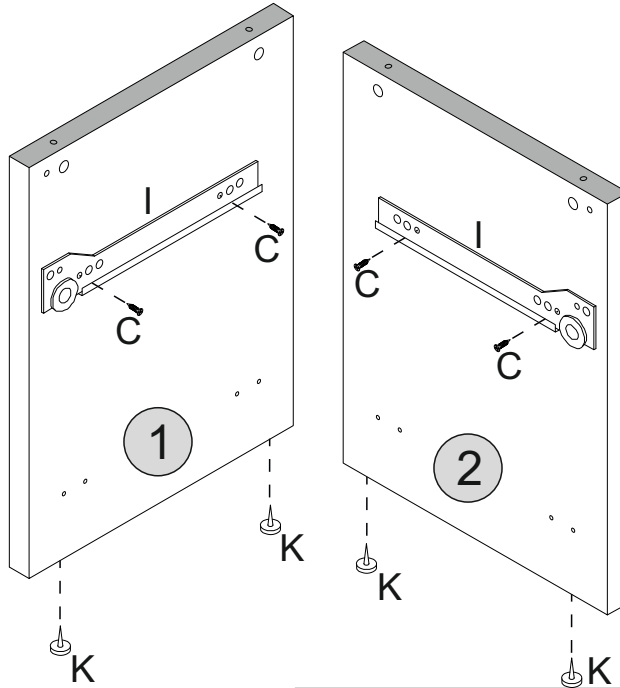
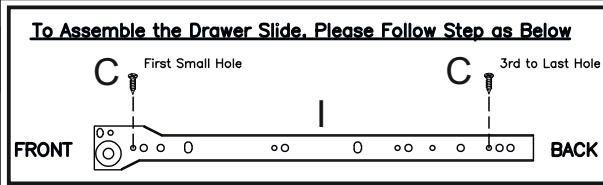
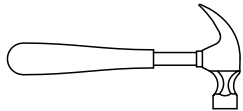
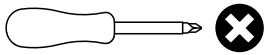

STEP 2

PARTS REQUIRED

7 - BOTTOM PANEL x1

8 - SUPPORT PANEL x1

HARDWARE REQUIRED

A  06

TOOLS REQUIRED

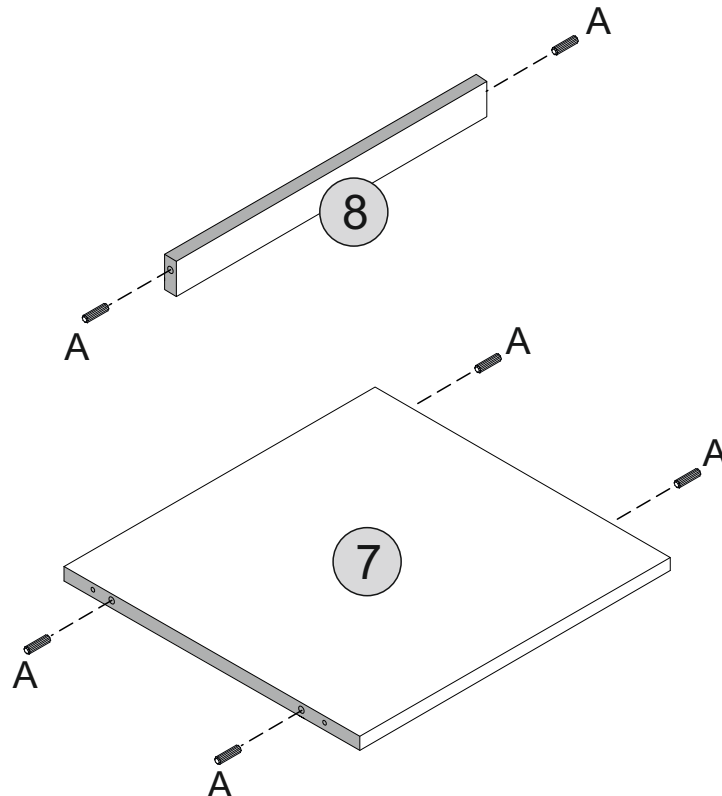

STEP 3

PARTS REQUIRED

| | |
|----------------------|----|
| 1 - LEFT SIDE PANEL | x1 |
| 2 - RIGHT SIDE PANEL | x1 |
| 7 - BOTTOM PANEL | x1 |
| 8 - SUPPORT PANEL | x1 |

HARDWARE REQUIRED

| | | |
|---|---|----|
| B |  | 04 |
|---|---|----|

TOOLS REQUIRED

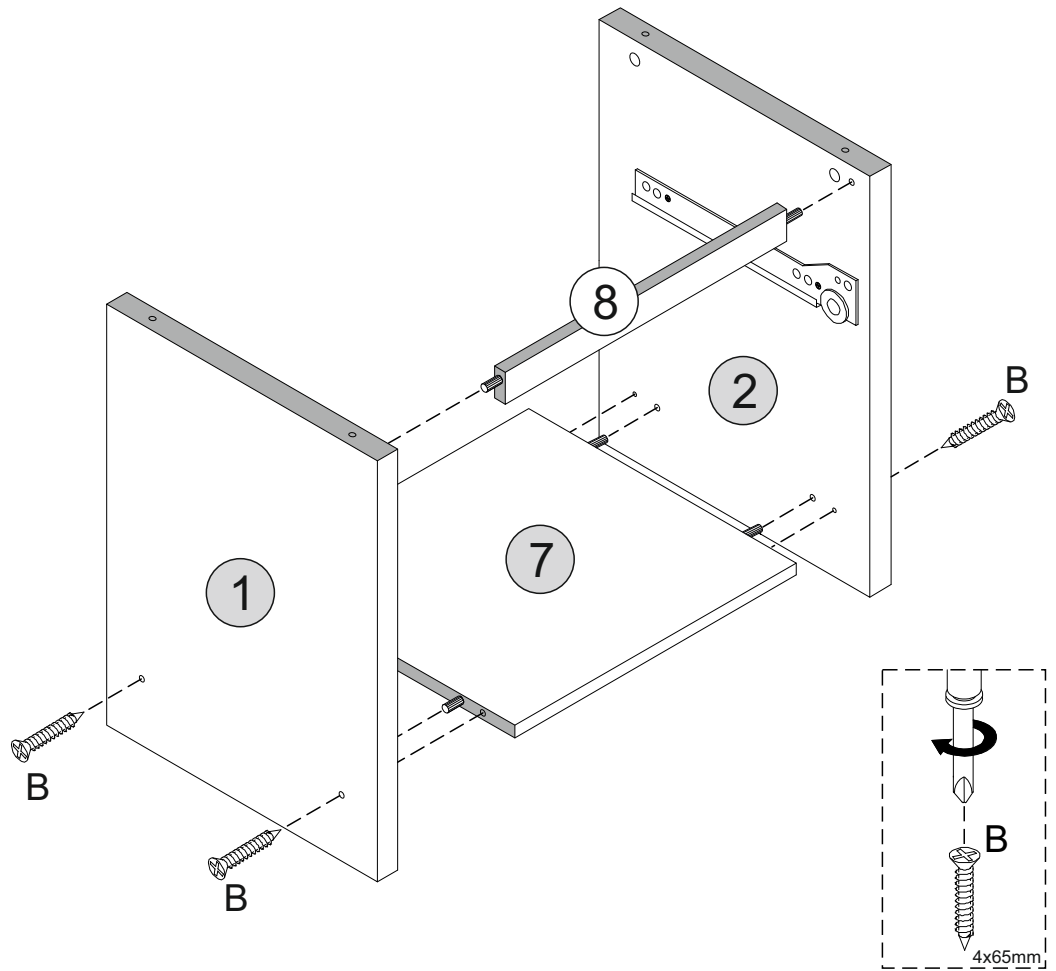
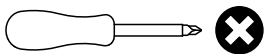

STEP 4

PARTS REQUIRED

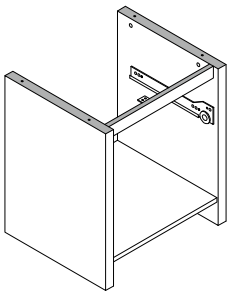

HARDWARE REQUIRED

| | | |
|---|---|----|
| F |  | 04 |
|---|---|----|

| | | |
|---|---|----|
| M |  | 04 |
|---|---|----|

TOOLS REQUIRED

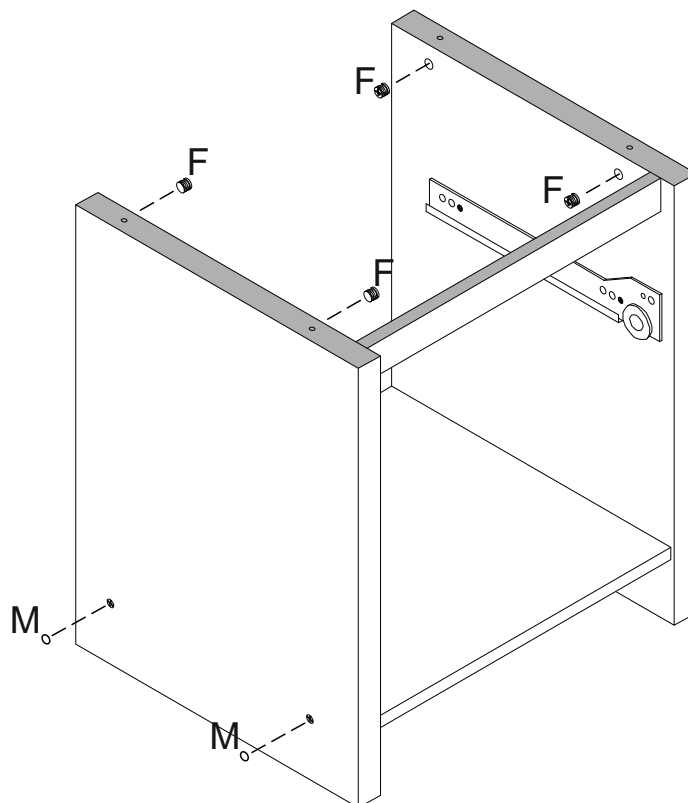

STEP 5

PARTS REQUIRED

6 - TOP PANEL x1

HARDWARE REQUIRED

C  02
3.5x14mm

E  04

J  01

TOOLS REQUIRED

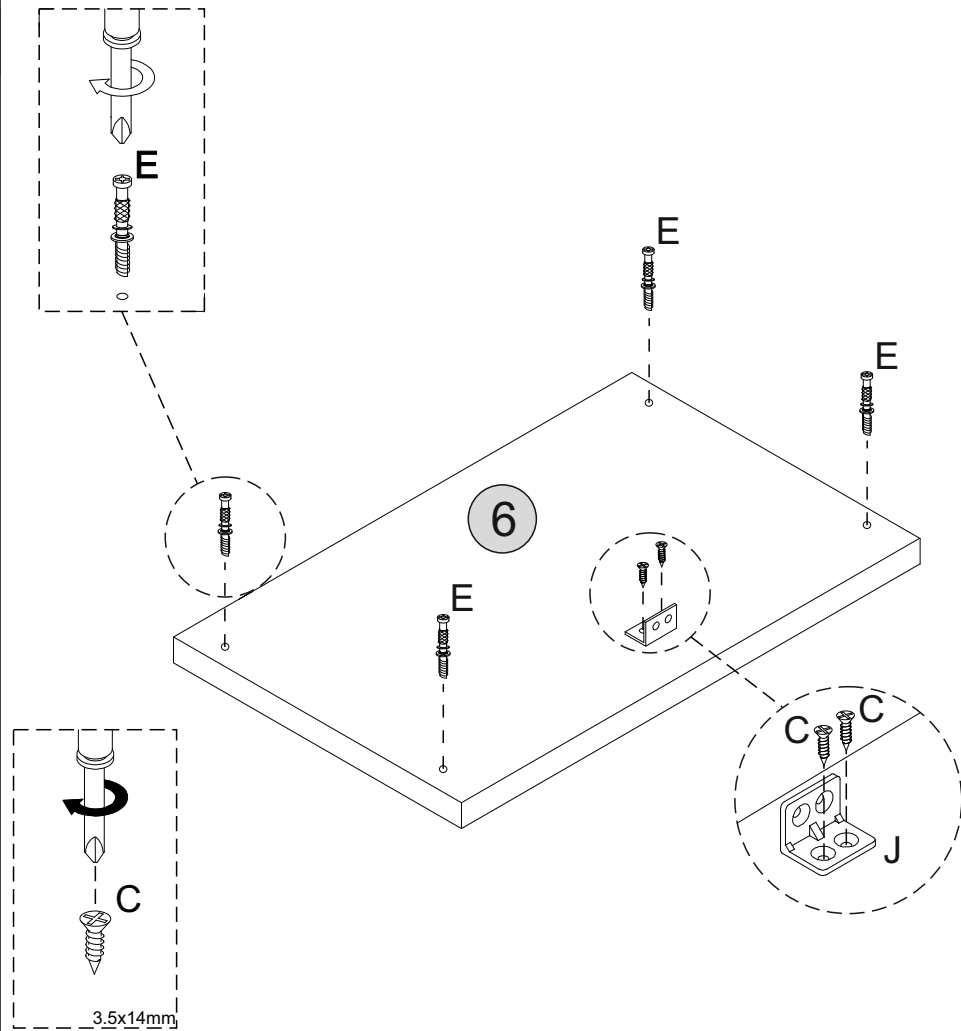
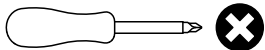

STEP 6

PARTS REQUIRED

6 - TOP PANEL x1

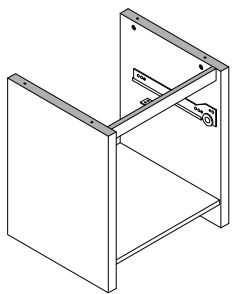

HARDWARE REQUIRED

C  02
3.5x14mm

TOOLS REQUIRED

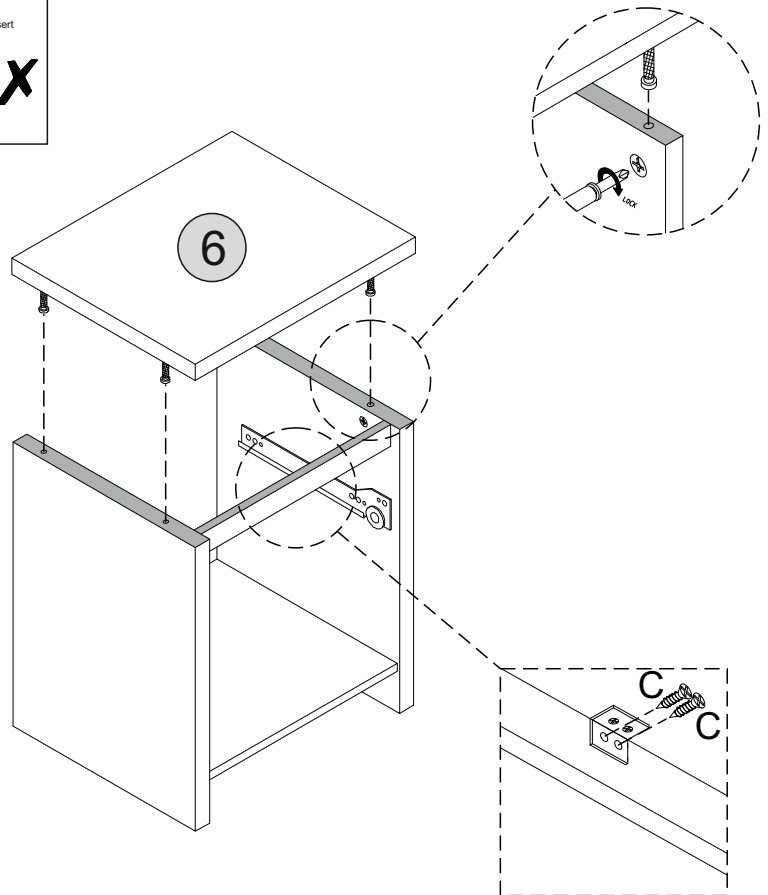
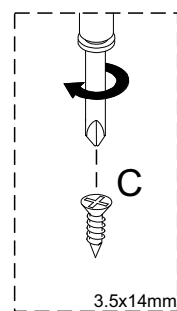
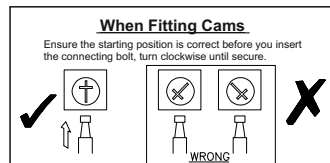
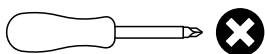

STEP 7

PARTS REQUIRED

11 - BACK PANEL x1

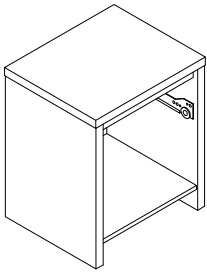

HARDWARE REQUIRED

L  24

TOOLS REQUIRED

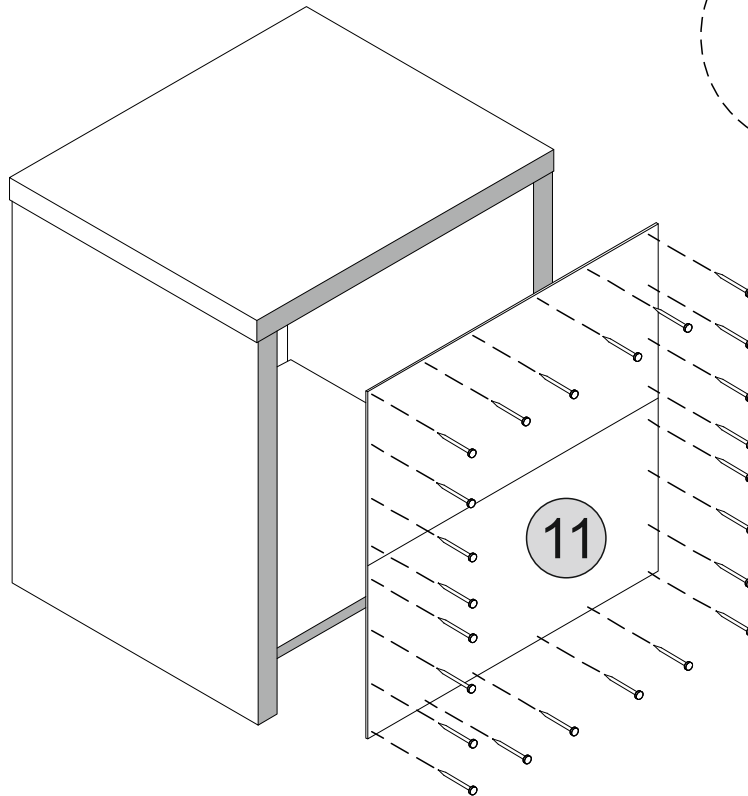
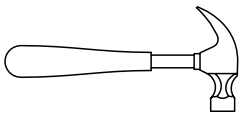

STEP 8

PARTS REQUIRED

3 - DRAWER FRONT x1

4 - LEFT DRAWER SIDE x1

5 - RIGHT DRAWER SIDE x1

HARDWARE REQUIRED

A  04

E  02

F  02

TOOLS REQUIRED

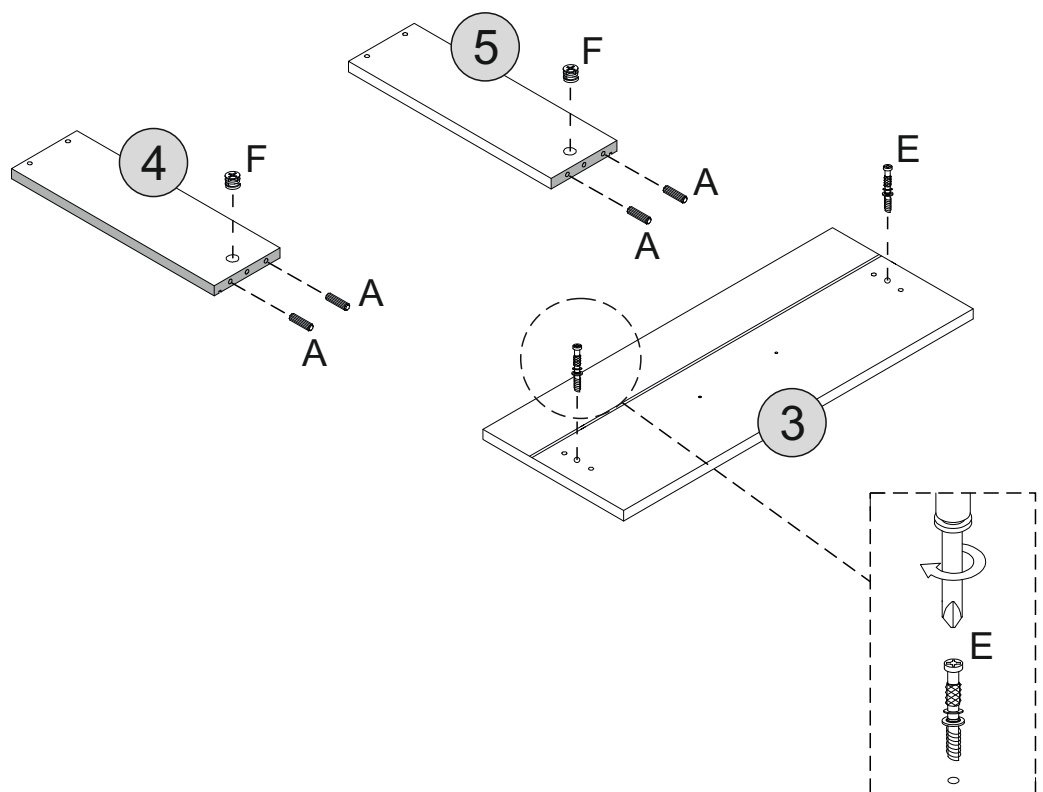
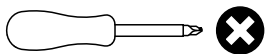

STEP 9

PARTS REQUIRED

4 - LEFT DRAWER SIDE x1

5 - RIGHT DRAWER SIDE x1

9 - DRAWER BACK x1

HARDWARE REQUIRED

D  04

TOOLS REQUIRED

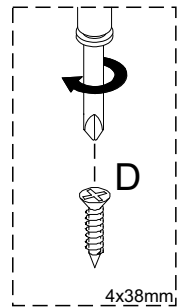
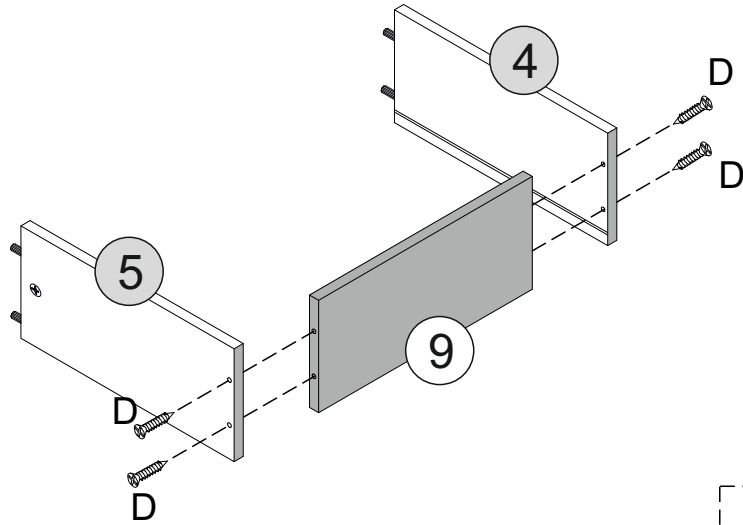
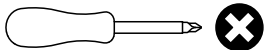

STEP 10

PARTS REQUIRED

7 - BOTTOM PANEL x1

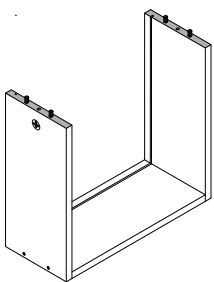

HARDWARE REQUIRED

TOOLS REQUIRED

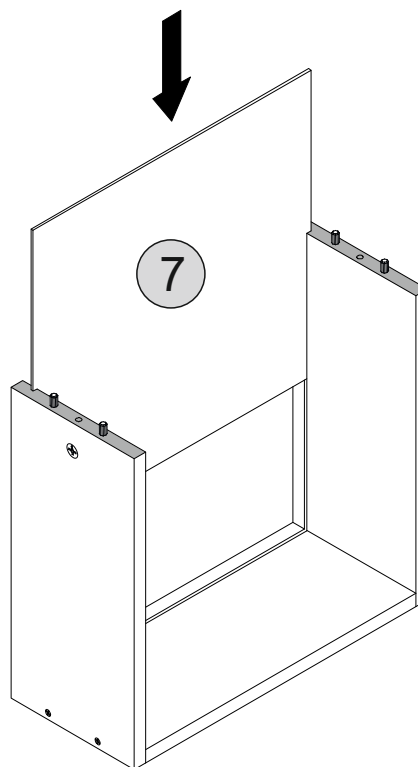

STEP 11

PARTS REQUIRED

3 - DRAWER FRONT x1

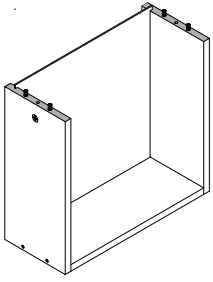

HARDWARE REQUIRED

TOOLS REQUIRED

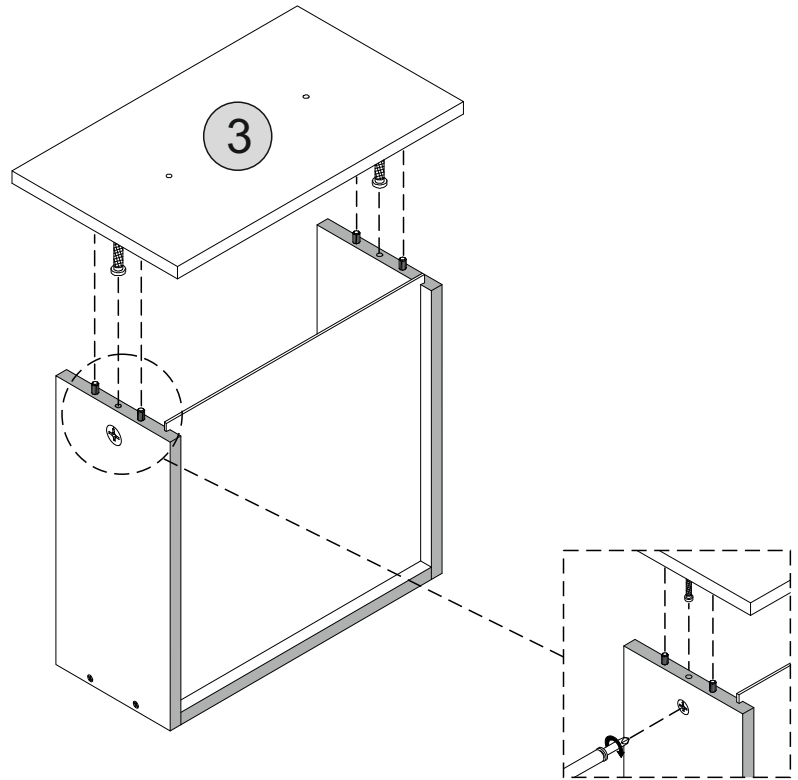
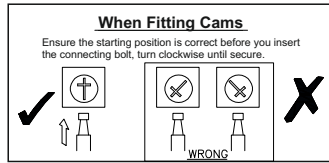
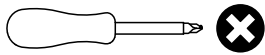

STEP 12

PARTS REQUIRED

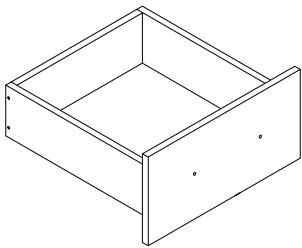

HARDWARE REQUIRED

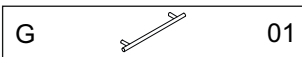

TOOLS REQUIRED

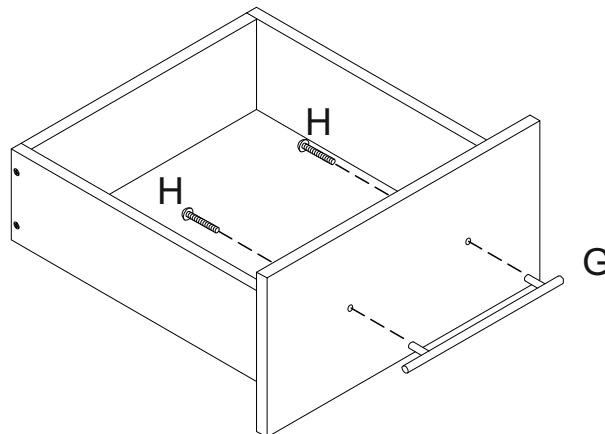
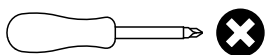

STEP 13

PARTS REQUIRED

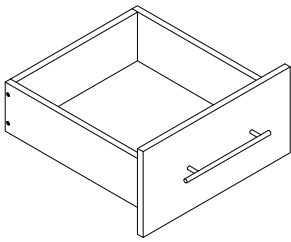

HARDWARE REQUIRED

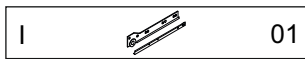
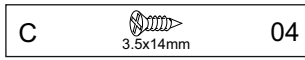

TOOLS REQUIRED

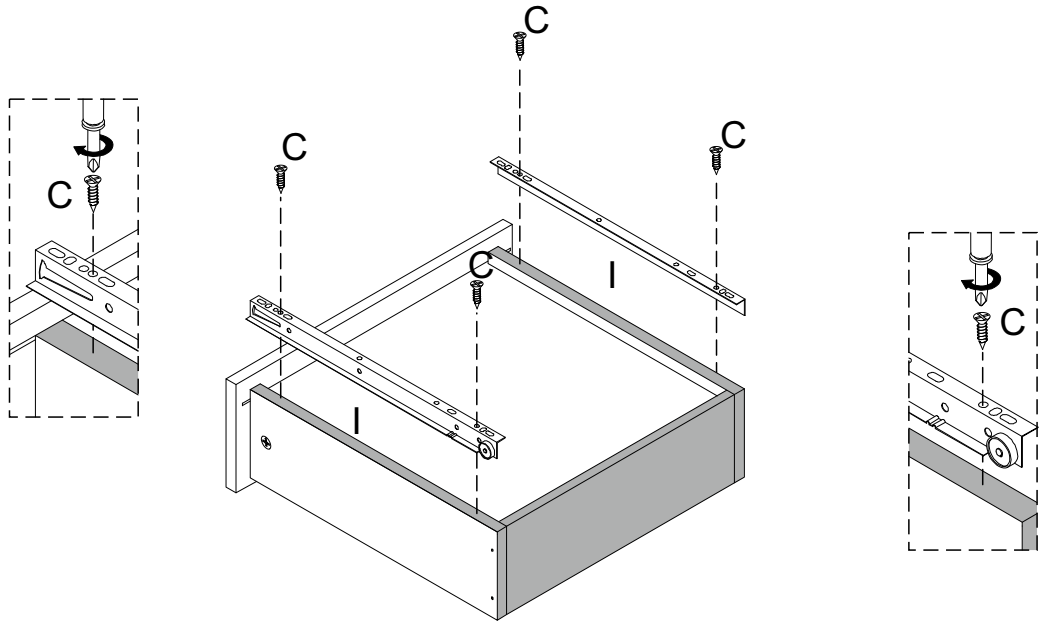
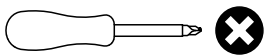

STEP 14

PARTS REQUIRED

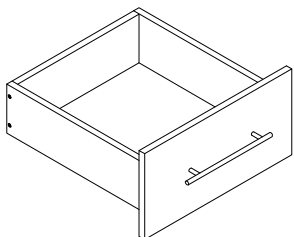
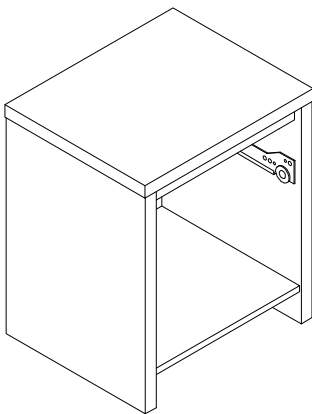

HARDWARE REQUIRED

TOOLS REQUIRED

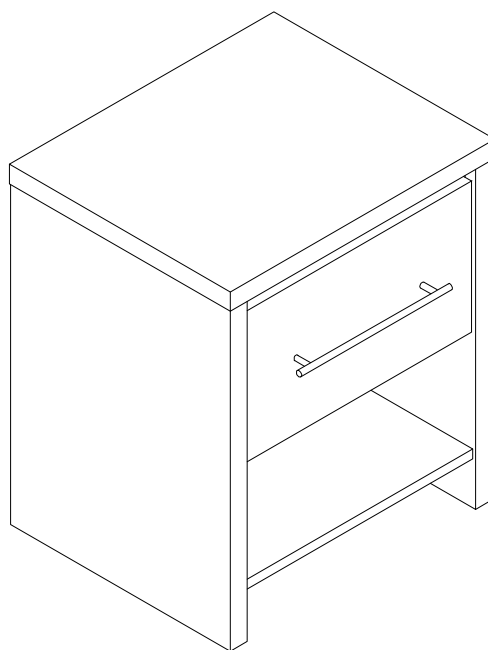

!
PLEASE NOTE THE CLEAR
PROTECTIVE FILM WHICH
NEEDS REMOVING FROM
THE GLOSS FINISH.

