

# WHITE GLOSS SEVILLE 1 DRAWER BEDSIDE ASSEMBLY INSTRUCTIONS

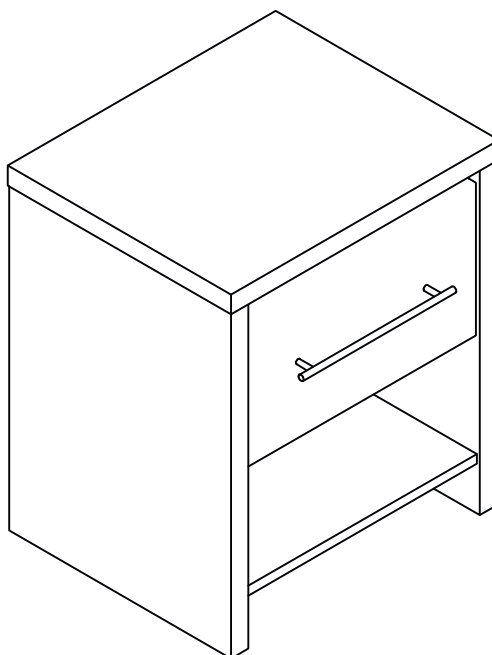

FOR DOMESTIC USE ONLY  
IMPORTANT

PLEASE READ BEFORE YOU CONTINUE FURTHER

THE PRODUCT YOU HAVE PURCHASED WILL GIVE YOU MANY YEARS OF SERVICE IF YOU FOLLOW THE GUIDELINES FOR ITS SAFE ASSEMBLY AND PERIODIC MAINTENANCE AND CLEANING.

ASSEMBLE ON A SOFT CLEAN SURFACE.

DO NOT USE ANY TOOLS OTHER THAN THOSE SHOWN.

ANY SPANNERS OR ALLEN KEYS REQUIRED ARE INCLUDED WITH THE FITTING KIT.

DO NOT FOR ANY REASON USE A POWER TOOL TO ASSEMBLE THIS PRODUCT. ITS USE WILL INVALIDATE ANY CLAIM YOU MAY HAVE AND COULD MAKE THIS PRODUCT UNSAFE.

DEPENDING ON THE AMOUNT OF USE THIS PRODUCT RECEIVES, IT MAY BE NECESSARY TO TIGHTEN UP THE FIXINGS FROM TIME TO TIME. THIS IS COMPLETELY NORMAL FOR ANY FLAT PACK FURNITURE. DO NOT OVERTIGHTEN FIXINGS.

FOR CLEANING, YOU MAY USE A DAMP CLOTH (NOT WET). DO NOT USE POLISH, DETERGENT OR CHEMICAL CLEANERS.



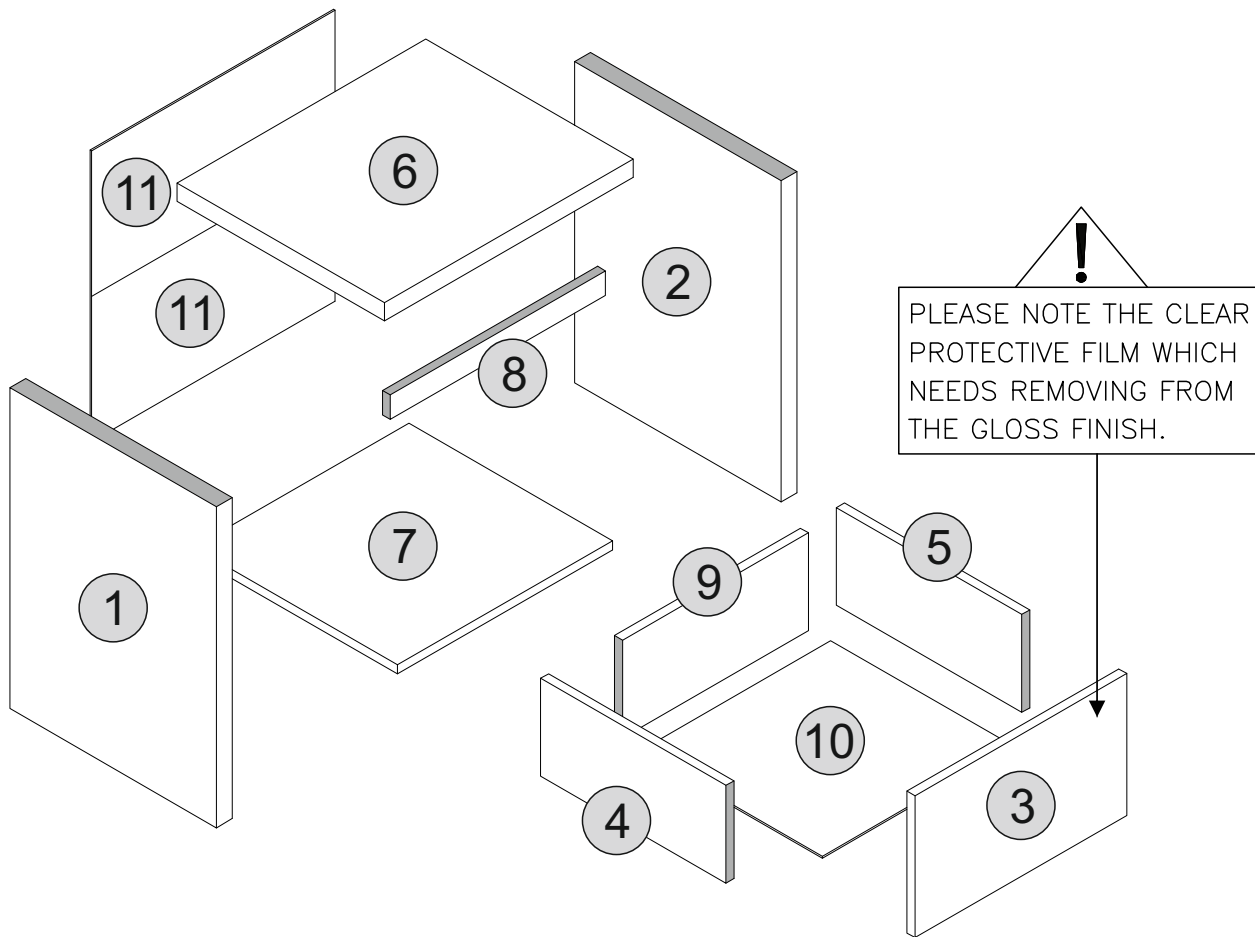









THIS SURFACE OF THIS ITEM IS NOT HEAT RESISTANT. ALWAYS USE A PLACE MAT UNDER HOT OR COLD ITEMS TO PREVENT MARKING.



## PART LIST

Part Number	Part Code	Part Description	Quantity	Carton
1	S100-103-027-ZF1-01	Left Side Panel	1	1/1
2	S100-103-027-ZF1-02	Right Side Panel	1	1/1
3	S100-103-027-ZF1-03	Drawer Front	1	1/1
4	S100-103-027-ZF1-04	Left Drawer Side	1	1/1
5	S100-103-027-ZF1-05	Right Drawer Side	1	1/1
6	S100-103-027-ZF1-06	Top Panel	1	1/1
7	S100-103-027-ZF1-07	Bottom Panel	1	1/1
8	S100-103-027-ZF1-08	Support Panel	1	1/1
9	S100-103-027-ZF1-09	Drawer Back	1	1/1
10	S100-103-027-ZF1-10	Drawer Base	1	1/1
11	S100-103-027-ZF1-11	Back Panel	2	1/1

# HARDWARE LIST

No.	Part Name		Qty
A	Wooden Dowel (6x25mm)		x10
B	65mm Screw (4x65mm)		x4
C	14mm Screw (3.5x14mm)		x12
D	38mm Screw (4x38mm)		x4
E	Cam Bolt (8032T)		x6
F	Cam Nut (1512)		x6
G	10" Handle (192mm)		x1
H	20mm Handle Screw		x1
I	14" Drawer Slide		x1
J	PVC L - Bracket		x1
K	Plastic Foot		x4
L	6/8" Nail		x24
M	Screw Cover (Sticker 12mm)		x4

## TIPS FOR FITTINGS CAM-LOCKS

WHEN FITTING CAM NUT, ENSURE STARTING POSITION IS CORRECT BEFORE YOU INSERT. CONNECTING CAM BOLT TURN CLOCKWISE UNTIL SECURE

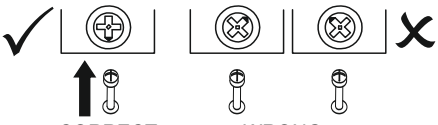

**CORRECT**      **WRONG**

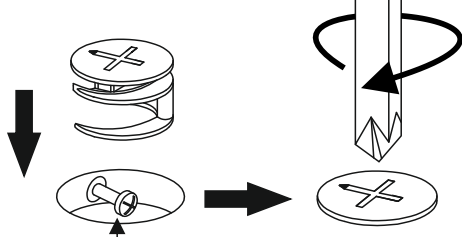

Cam bolt head needs to be in centre

### CAMBOLT

Tighten until shoulder in flush with panel. Do not overtighten or undertighten (see example below)

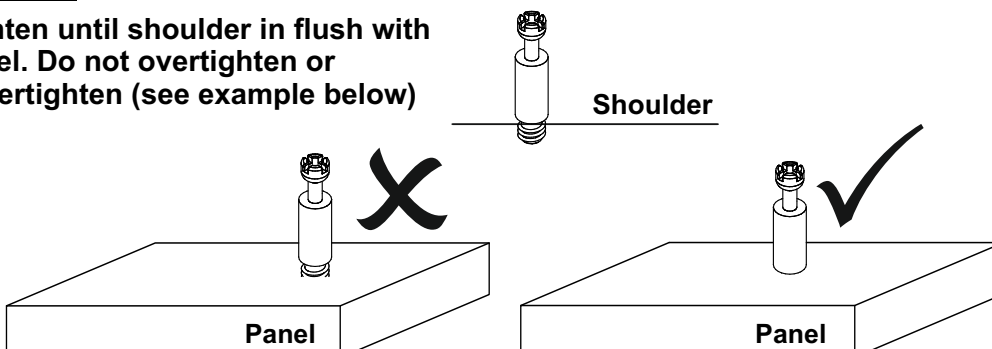

**Shoulder**

**Panel**      **Panel**

# STEP 1

## PARTS REQUIRED

1 - LEFT SIDE PANEL x1

2 - RIGHT SIDE PANEL x1

## HARDWARE REQUIRED

C  04  
3.5x14mm

I  01

K  04

## TOOLS REQUIRED

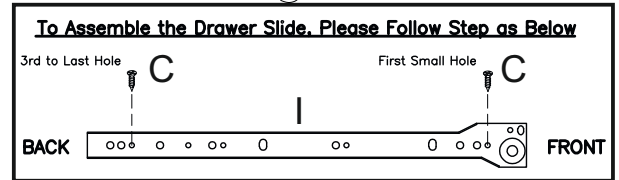
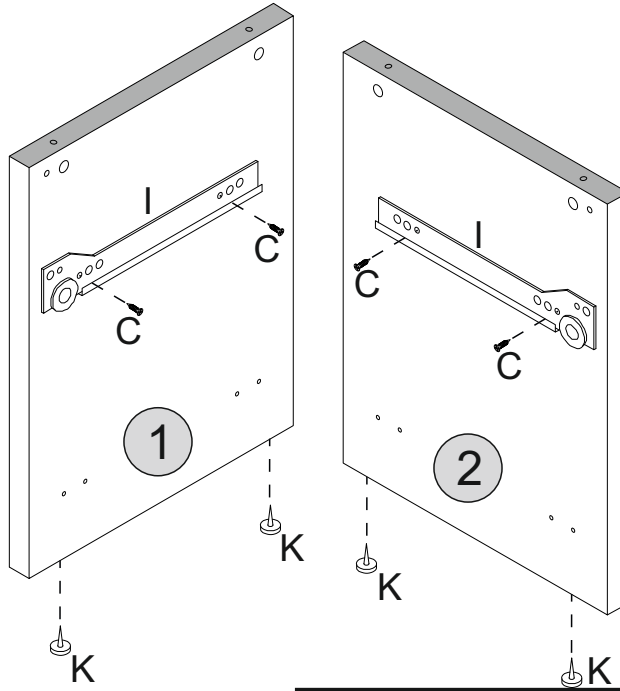
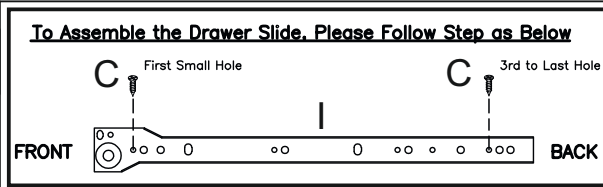
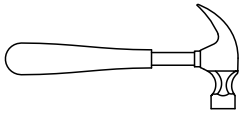
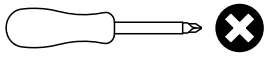

# STEP 2

## PARTS REQUIRED

7 - BOTTOM PANEL x1

8 - SUPPORT PANEL x1

## HARDWARE REQUIRED

A  06

## TOOLS REQUIRED

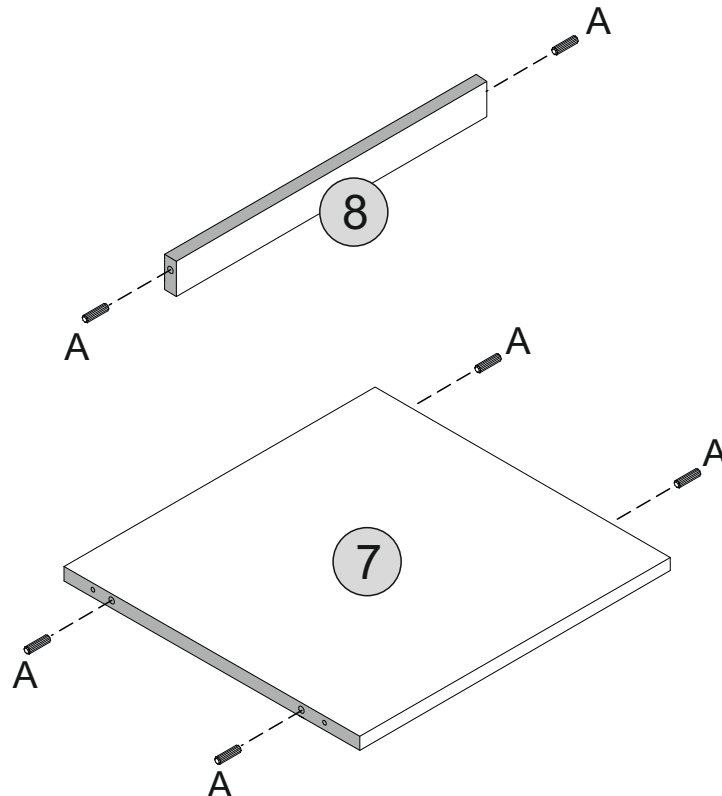

# STEP 3

## PARTS REQUIRED

1 - LEFT SIDE PANEL	x1
2 - RIGHT SIDE PANEL	x1
7 - BOTTOM PANEL	x1
8 - SUPPORT PANEL	x1

## HARDWARE REQUIRED

B		04
---	---	----

## TOOLS REQUIRED

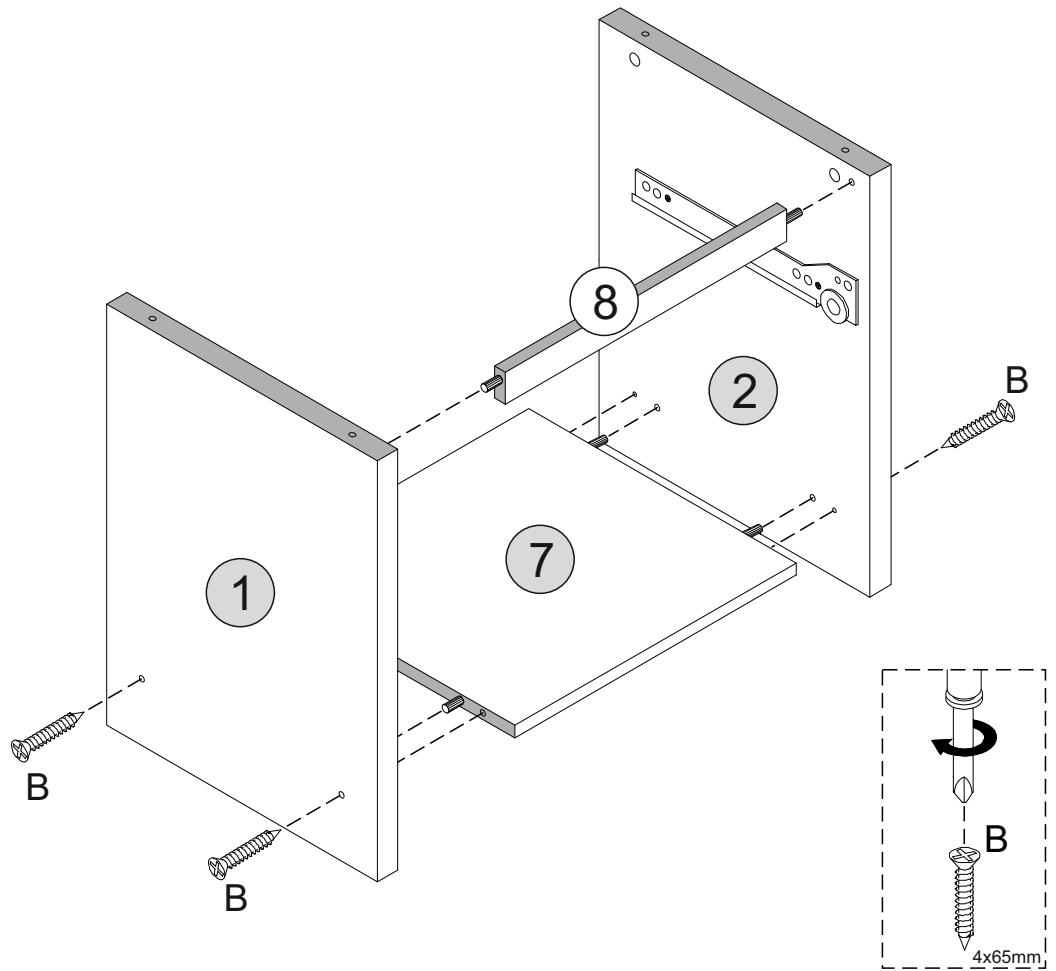
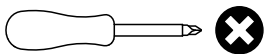

# STEP 4

## PARTS REQUIRED

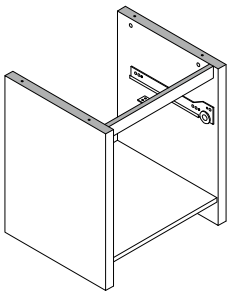

## HARDWARE REQUIRED

F		04
---	---	----

M		04
---	---	----

## TOOLS REQUIRED

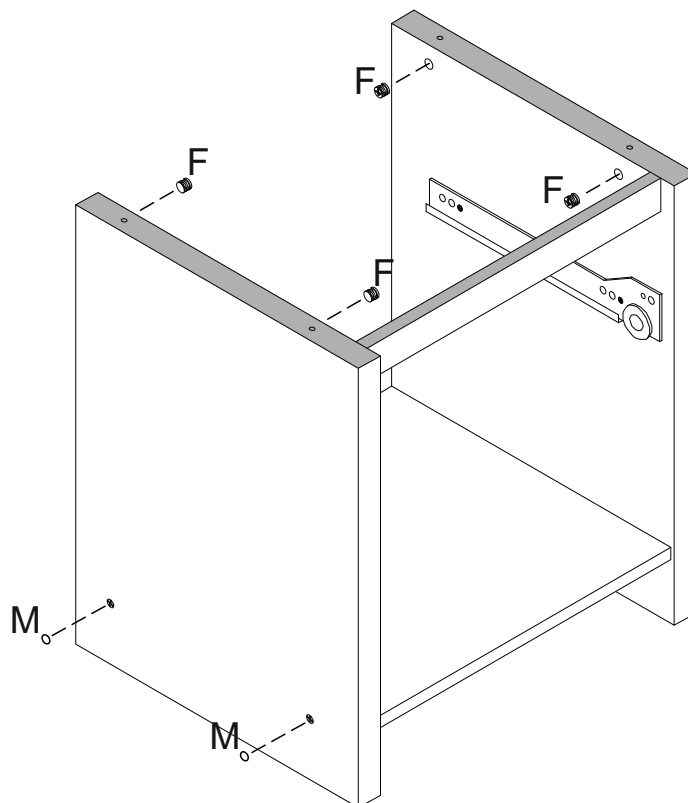

# STEP 5

## PARTS REQUIRED

6 - TOP PANEL x1

## HARDWARE REQUIRED

C  02  
3.5x14mm

E  04

J  01

## TOOLS REQUIRED

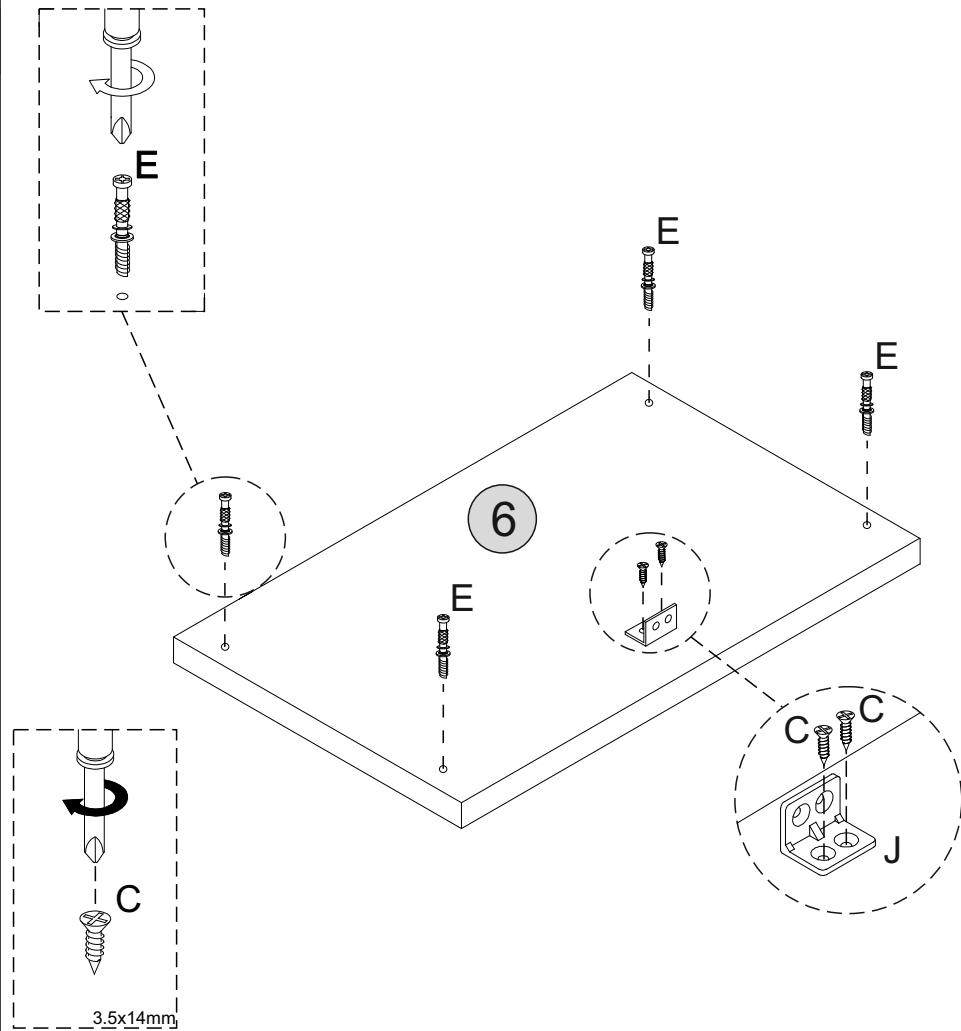
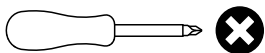

# STEP 6

## PARTS REQUIRED

6 - TOP PANEL x1

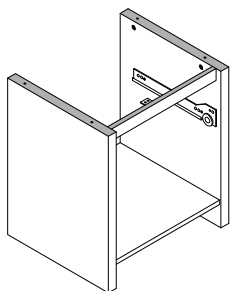

## HARDWARE REQUIRED

C  02  
3.5x14mm

## TOOLS REQUIRED

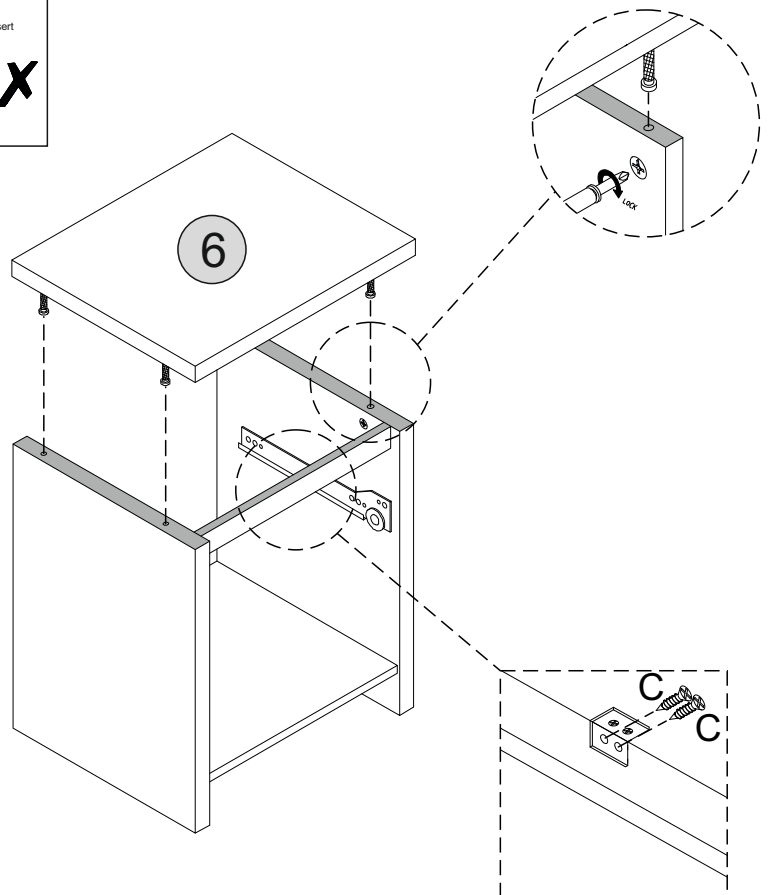
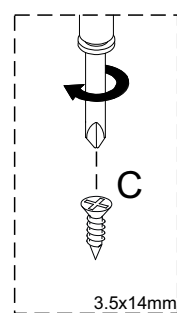
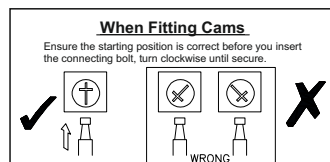
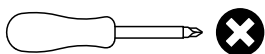

# STEP 7

## PARTS REQUIRED

11 - BACK PANEL x1

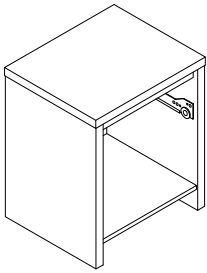

## HARDWARE REQUIRED

L  24

## TOOLS REQUIRED

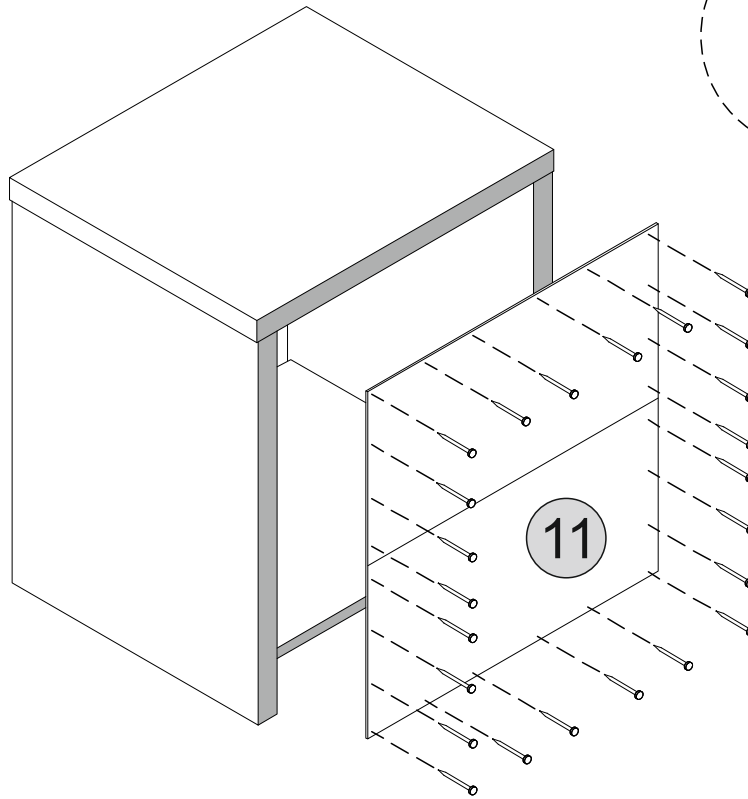
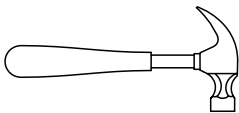

# STEP 8

## PARTS REQUIRED

3 - DRAWER FRONT x1

4 - LEFT DRAWER SIDE x1

5 - RIGHT DRAWER SIDE x1

## HARDWARE REQUIRED

A  04

E  02

F  02

## TOOLS REQUIRED

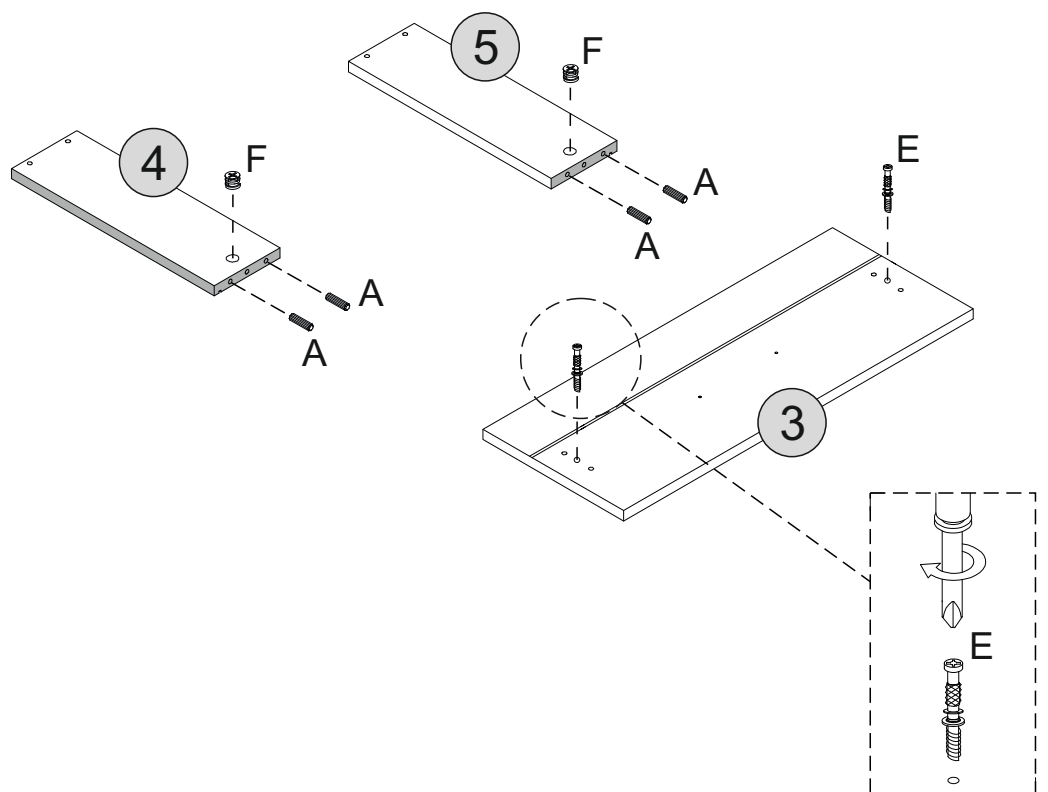
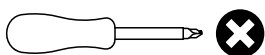

# STEP 9

## PARTS REQUIRED

4 - LEFT DRAWER SIDE x1

5 - RIGHT DRAWER SIDE x1

9 - DRAWER BACK x1

## HARDWARE REQUIRED

D  04

## TOOLS REQUIRED

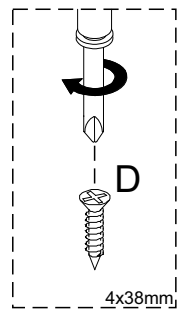
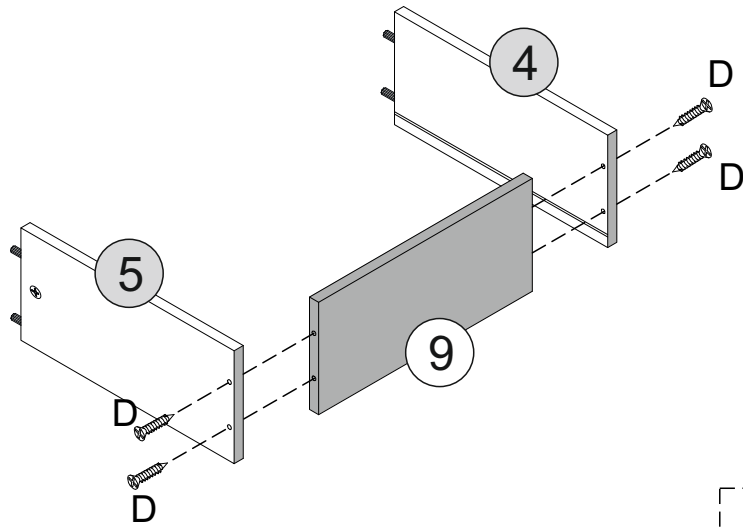
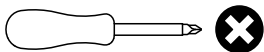

# STEP 10

## PARTS REQUIRED

7 - BOTTOM PANEL x1

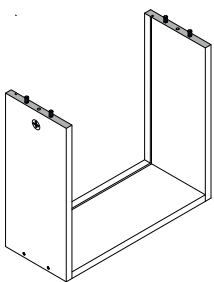

## HARDWARE REQUIRED

## TOOLS REQUIRED

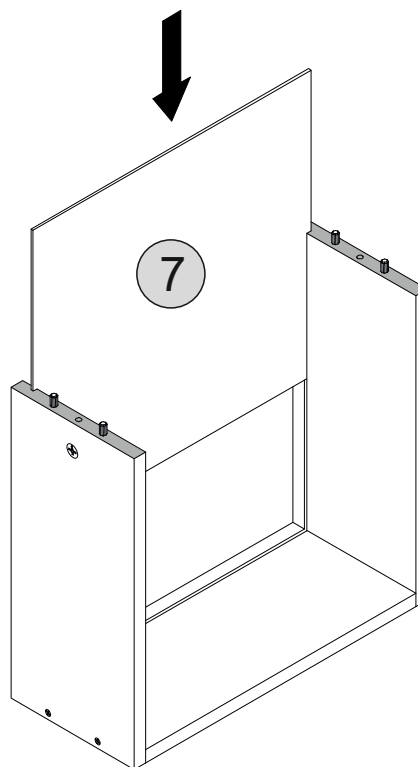



# STEP 11

## PARTS REQUIRED

3 - DRAWER FRONT x1

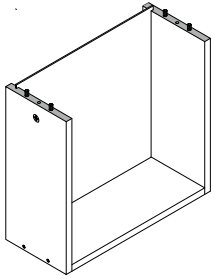

## HARDWARE REQUIRED

## TOOLS REQUIRED

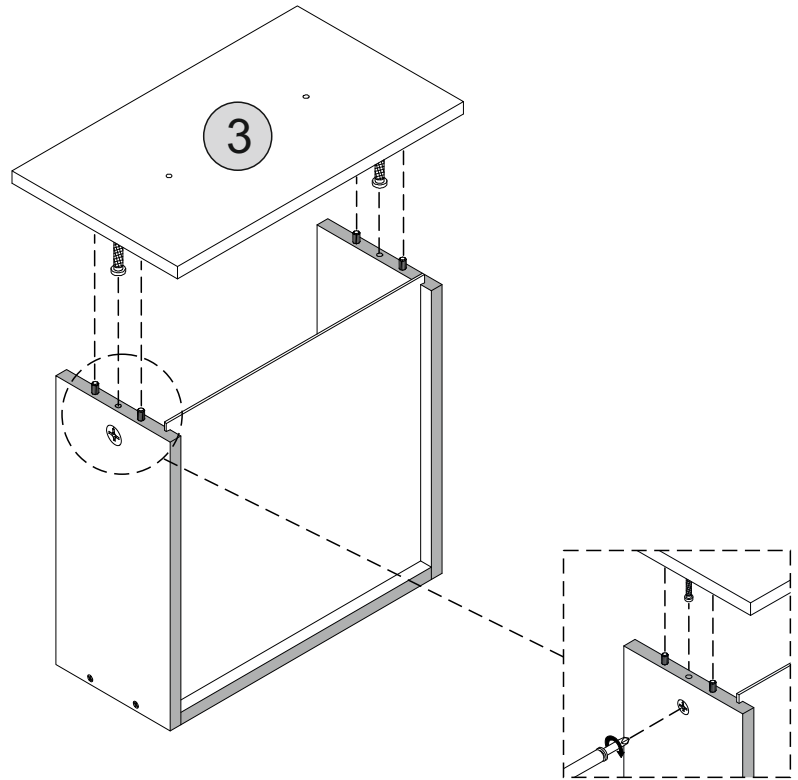
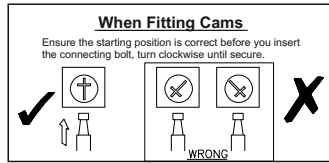
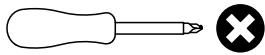

# STEP 12

## PARTS REQUIRED

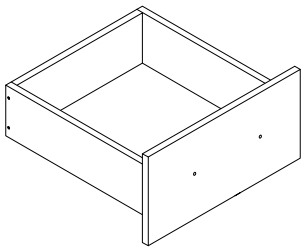

## HARDWARE REQUIRED

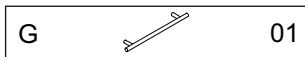

## TOOLS REQUIRED

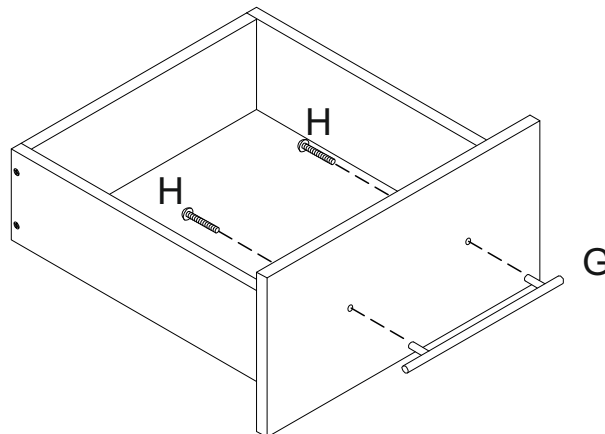
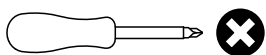

# STEP 13

**PARTS REQUIRED**

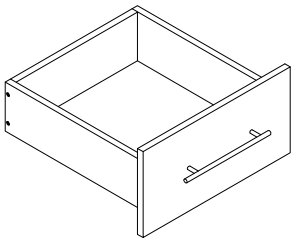

**HARDWARE REQUIRED**

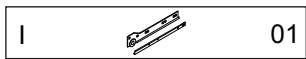
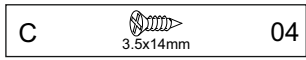

**TOOLS REQUIRED**

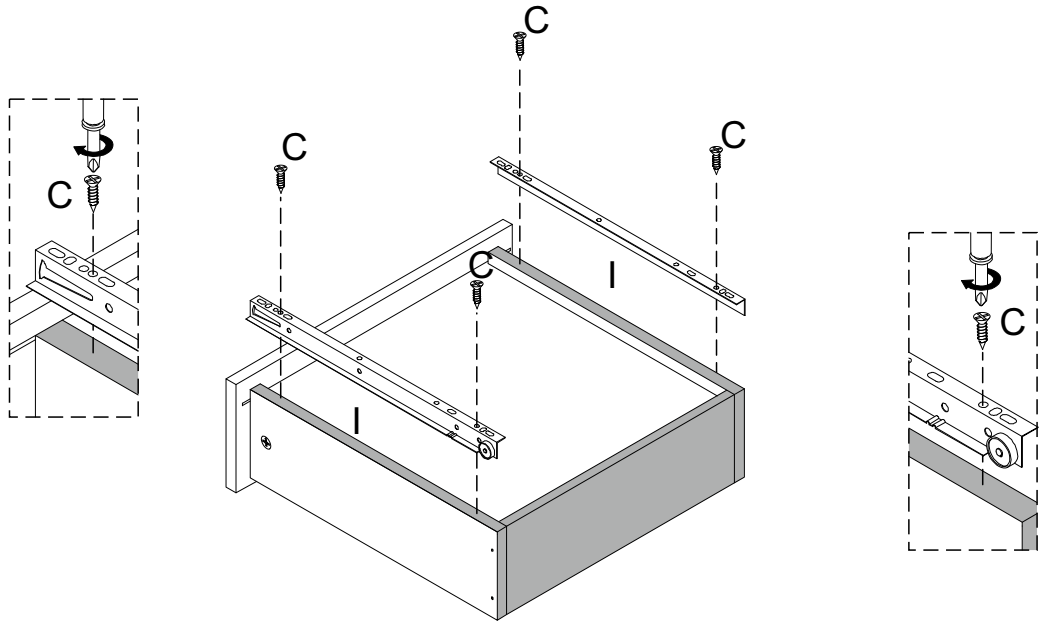
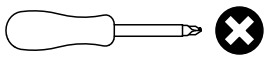

# STEP 14

**PARTS REQUIRED**

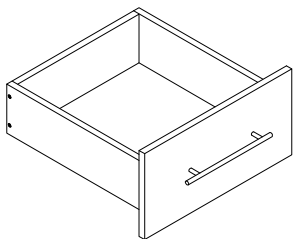
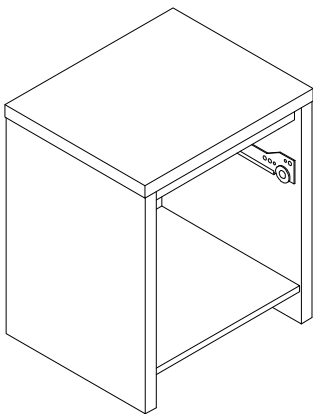

**HARDWARE REQUIRED**

**TOOLS REQUIRED**

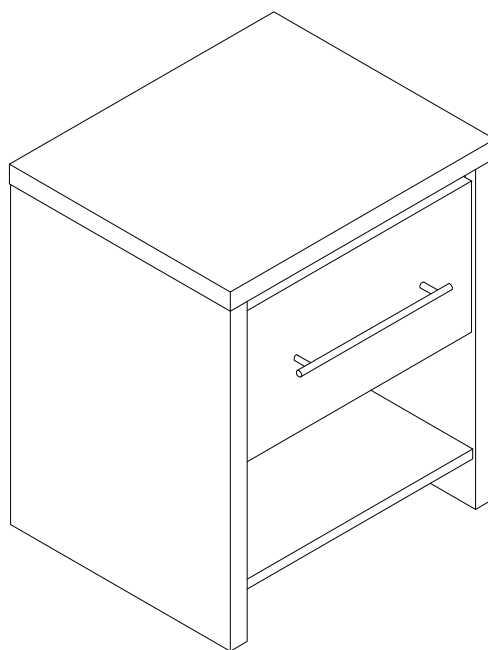

**!**  
PLEASE NOTE THE CLEAR  
PROTECTIVE FILM WHICH  
NEEDS REMOVING FROM  
THE GLOSS FINISH.

