

# NORDIC 2 DRAWER COFFEE TABLE ASSEMBLY INSTRUCTIONS

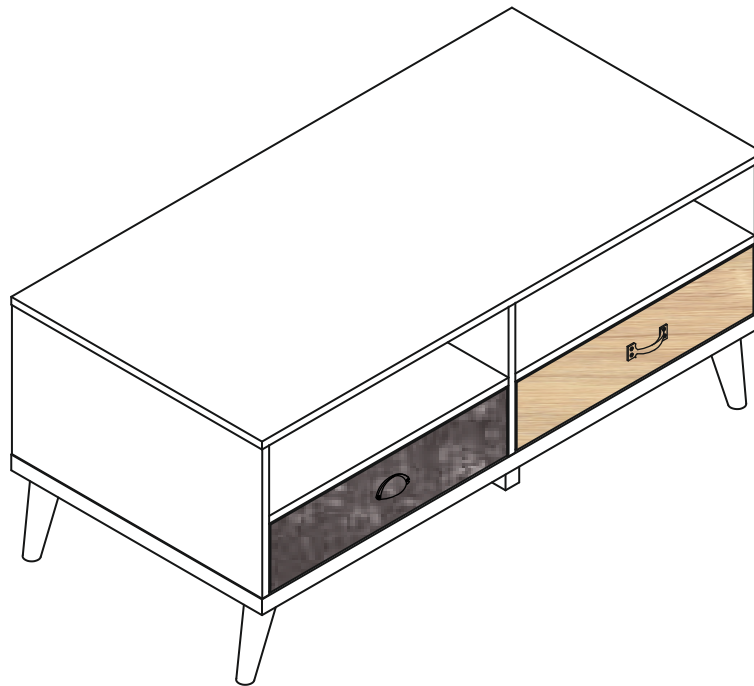

FOR DOMESTIC USE ONLY

IMPORTANT

PLEASE READ BEFORE YOU CONTINUE FURTHER

THE PRODUCT YOU HAVE PURCHASED WILL GIVE YOU MANY YEARS OF SERVICE IF YOU FOLLOW THE GUIDELINES FOR ITS SAFE ASSEMBLY AND PERIODIC MAINTENANCE AND CLEANING.

ASSEMBLE ON A SOFT CLEAN SURFACE.

DO NOT USE ANY TOOLS OTHER THAN THOSE SHOWN.

ANY SPANNERS OR ALLEN KEYS REQUIRED ARE INCLUDED WITH THE FITTING KIT.

DO NOT FOR ANY REASON USE A POWER TOOL TO ASSEMBLE THIS PRODUCT. ITS USE WILL INVALIDATE ANY CLAIM YOU MAY HAVE AND COULD MAKE THIS PRODUCT UNSAFE.

DEPENDING ON THE AMOUNT OF USE THIS PRODUCT RECEIVES, IT MAY BE NECESSARY TO TIGHTEN UP THE FIXINGS FROM TIME TO TIME. THIS IS COMPLETELY NORMAL FOR ANY FLAT PACK FURNITURE. DO NOT OVERTIGHTEN FIXINGS.

FOR CLEANING, YOU MAY USE A DAMP CLOTH (NOT WET). DO NOT USE POLISH, DETERGENT OR CHEMICAL CLEANERS.



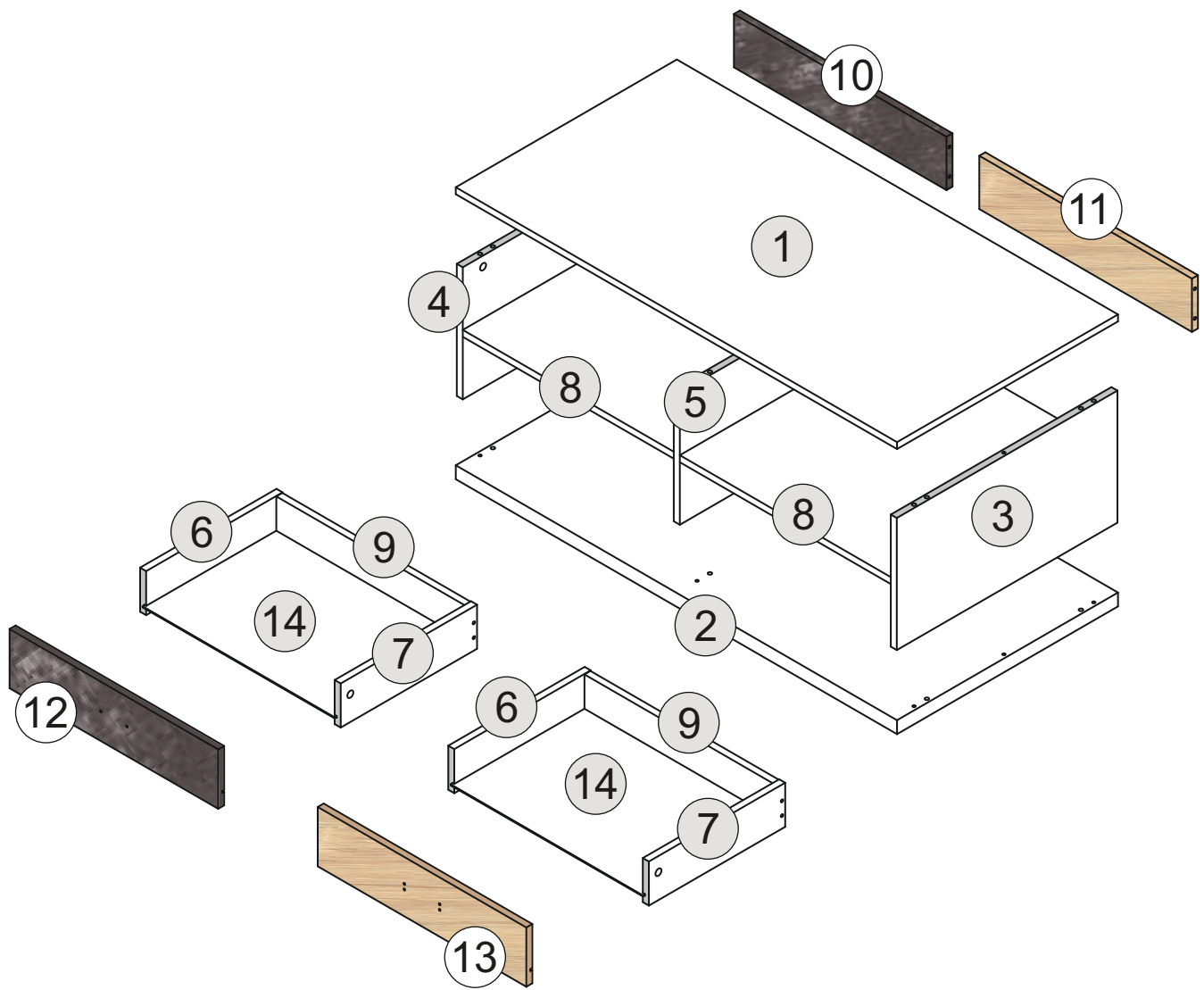











THIS SURFACE OF THIS ITEM IS NOT HEAT RESISTANT. ALWAYS USE A PLACE MAT UNDER HOT OR COLD ITEMS TO PREVENT MARKING.



## PART LIST

Part Number	Part Code	Part Description	Quantity	Carton
1	S300-301-058-ZF1-01	Top Panel	1	1/1
2	S300-301-058-ZF1-02	Bottom Panel	1	1/1
3	S300-301-058-ZF1-03	Right Side Panel	1	1/1
4	S300-301-058-ZF1-04	Left Side Panel	1	1/1
5	S300-301-058-ZF1-05	Centre Panel	1	1/1
6	S300-301-058-ZF1-06	Left Drawer Side	2	1/1
7	S300-301-058-ZF1-07	Right Drawer Side	2	1/1
8	S300-301-058-ZF1-08	Shelf Panel	2	1/1
9	S300-301-058-ZF1-09	Drawer Back Panel	2	1/1
10	S300-301-058-ZF1-10	Left Back Support Panel	1	1/1
11	S300-301-058-ZF1-11	Right Back Support Panel	1	1/1
12	S300-301-058-ZF1-12	Left Drawer Front	1	1/1
13	S300-301-058-ZF1-13	Right Drawer Front	1	1/1
14	S300-301-058-ZF1-14	Drawer Base	2	1/1

# HARDWARE LIST

No	Part Name		Qty	Carton
A	M8x25mm Wooden Dowel		x32	1
B	M4x45mm Screw		x6	1
C	M4x38mm Screw		x8	1
D	M3.5x14mm Screw		x32	1
E	Minifix Cam Bolt (8032t)		x10	1
F	Minifix Cam Nut (1512)		x10	1
G	Wood Leg + Plastic Foot		x4	1
H	Wood Leg + Plastic Foot		x1	1
I	14"Drawer Slide (0.9 - W)		x2	1
J	Handle + Screw <small>L-3510 (3x16mm=4pcs)</small>		x1	1
K	Handle + Screw <small>Y-8238 (3x16mm=2pcs)</small>		x1	1
L	PVC Back Support (AC100)		x4	1
M	4x20mm Screw		x4	1
N	6x35mm JCBC Screw (Z-Blue)		x1	1
O	Allen Key (M6)		x1	1

## TIPS FOR FITTINGS CAM-LOCKS

WHEN FITTING CAM NUT. ENSURE STARTING POSITION IS CORRECT BEFORE YOU INSERT CONNECTING CAM BOLT TURN CLOCKWISE UNTIL SECURE

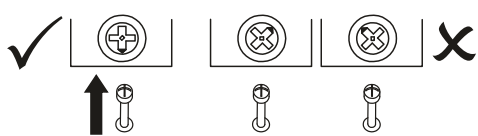

↑
↑
↑
↑

CORRECT
WRONG

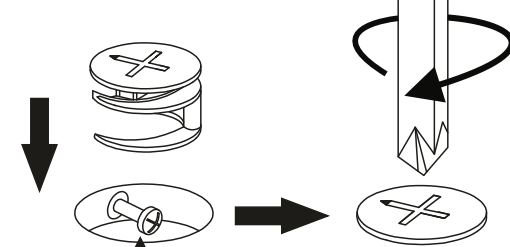

Cam bolt head needs to be in centre

### CAMBOLT

**Tighten until shoulder in flush with panel. Do not overtighten or undertighten (see example below)**

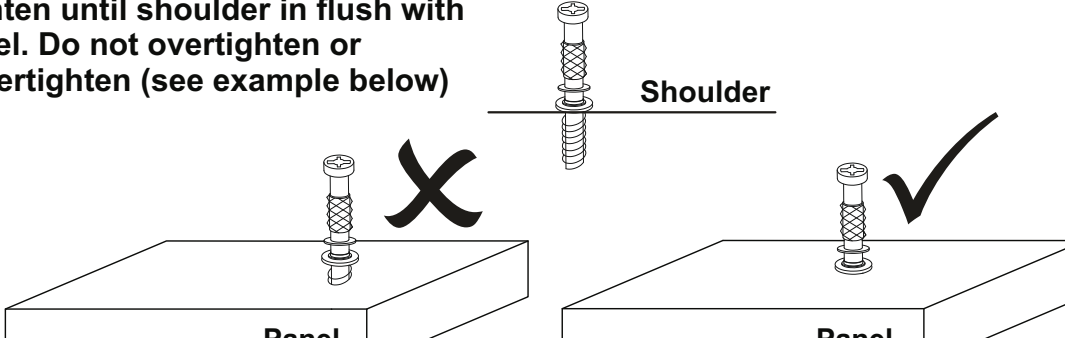

Shoulder

Panel                      Panel

# STEP 1

**PARTS REQUIRED**

8 - SHELF PANEL x2

10 - LEFT BACK SUPPORT PANEL x1

11 - RIGHT BACK SUPPORT PANEL x1

**HARDWARE REQUIRED**

A  16

**TOOLS REQUIRED**

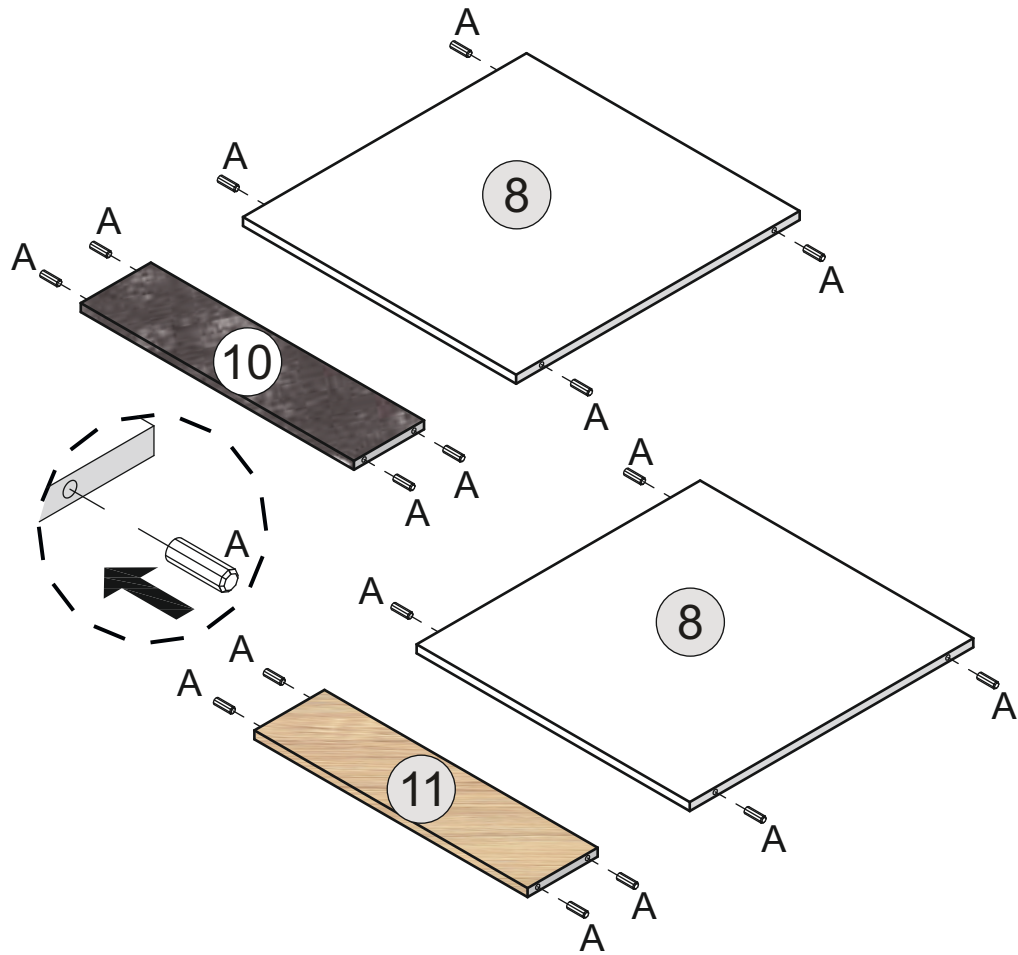

# STEP 2

**PARTS REQUIRED**



1 - TOP PANEL x1

**HARDWARE REQUIRED**

E  06

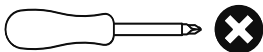
**TOOLS REQUIRED**

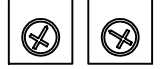

<p><b>WHEN FITTING CAM BOLT</b> ENSURE THE CAM STUD IS FULLY TIGHTEN IN</p> <div style="display: flex; justify-content: space-around;"> <div style="text-align: center;">  <p>✓</p> </div> <div style="text-align: center;">  <p>✗</p> </div> </div> <p style="text-align: center;">CORRECT      WRONG</p>	<p><b>WHEN FITTING CAMS</b> ENSURE STARTING POSITION IS CORRECT BEFORE YOU INSERT CONNECTING BOLT TURN CLOCKWISE UNTIL SECURE</p> <div style="display: flex; justify-content: space-around;"> <div style="text-align: center;">  <p>✓</p> </div> <div style="text-align: center;">  <p>✗</p> </div> </div> <p style="text-align: center;">CORRECT      WRONG</p>
--	--

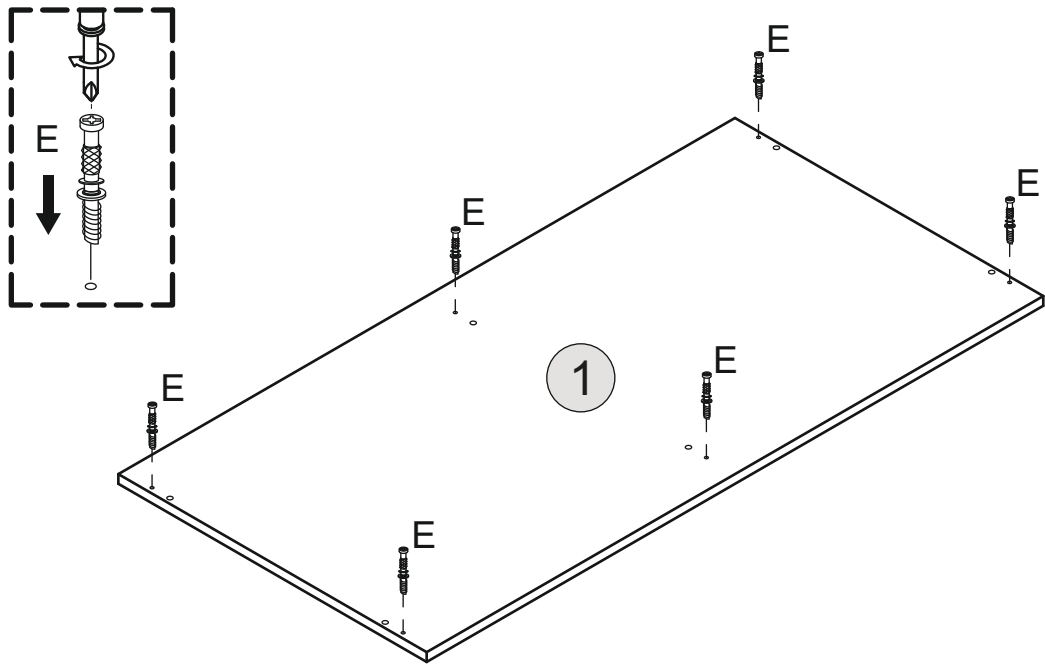

# STEP 3

**PARTS REQUIRED**

3 - RIGHT SIDE PANEL x1

4 - LEFT SIDE PANEL x1

5 - CENTRE PANEL x1

**HARDWARE REQUIRED**

A  12

F  06

**TOOLS REQUIRED**

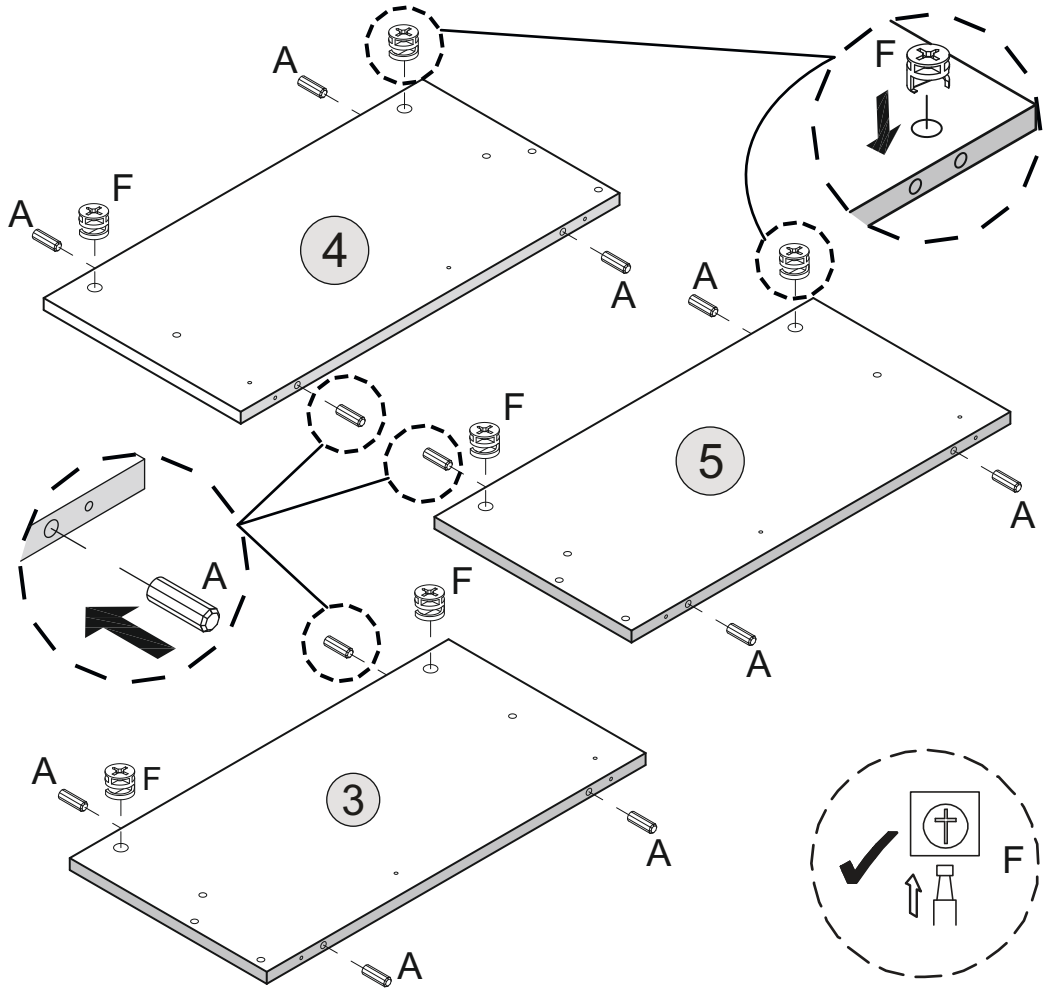

# STEP 4

**PARTS REQUIRED**

3 - RIGHT SIDE PANEL x1

4 - LEFT SIDE PANEL x1

5 - CENTRE PANEL x1

**HARDWARE REQUIRED**

D  06

I  03

**TOOLS REQUIRED**

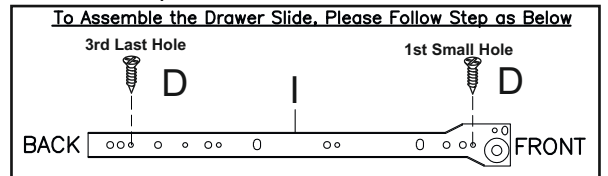
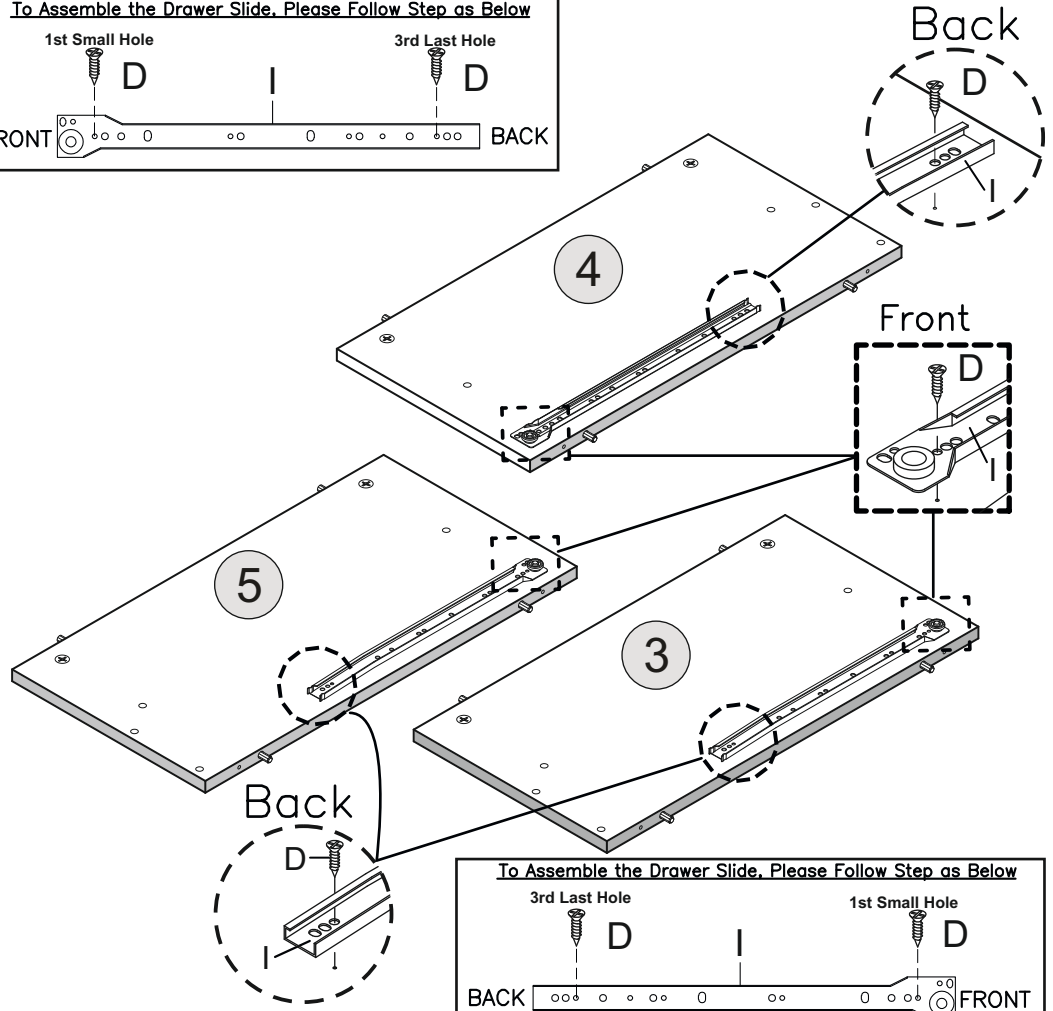
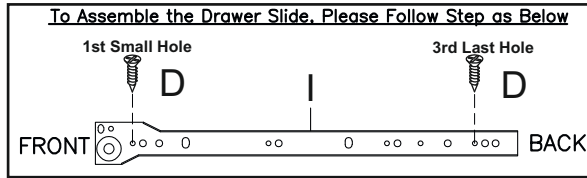
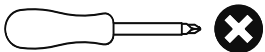

# STEP 5

PARTS REQUIRED

5 - CENTRE PANEL x1

HARDWARE REQUIRED

D  02

I  01

TOOLS REQUIRED

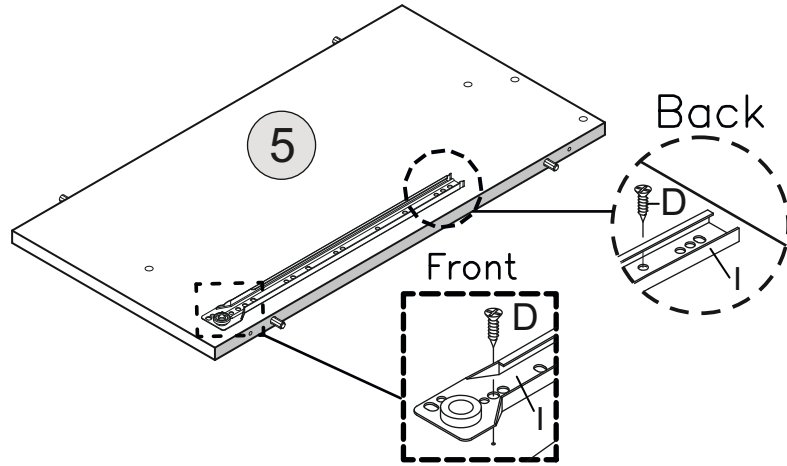
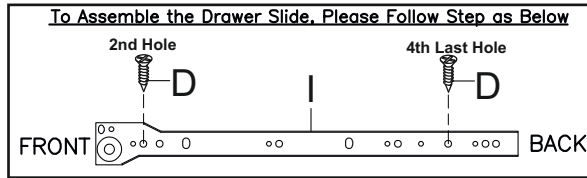
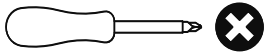

# STEP 6

PARTS REQUIRED

5 - CENTRE PANEL x1

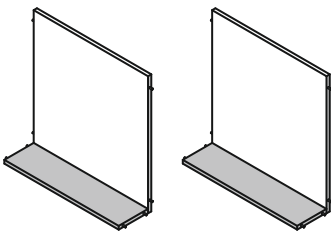

HARDWARE REQUIRED

TOOLS REQUIRED

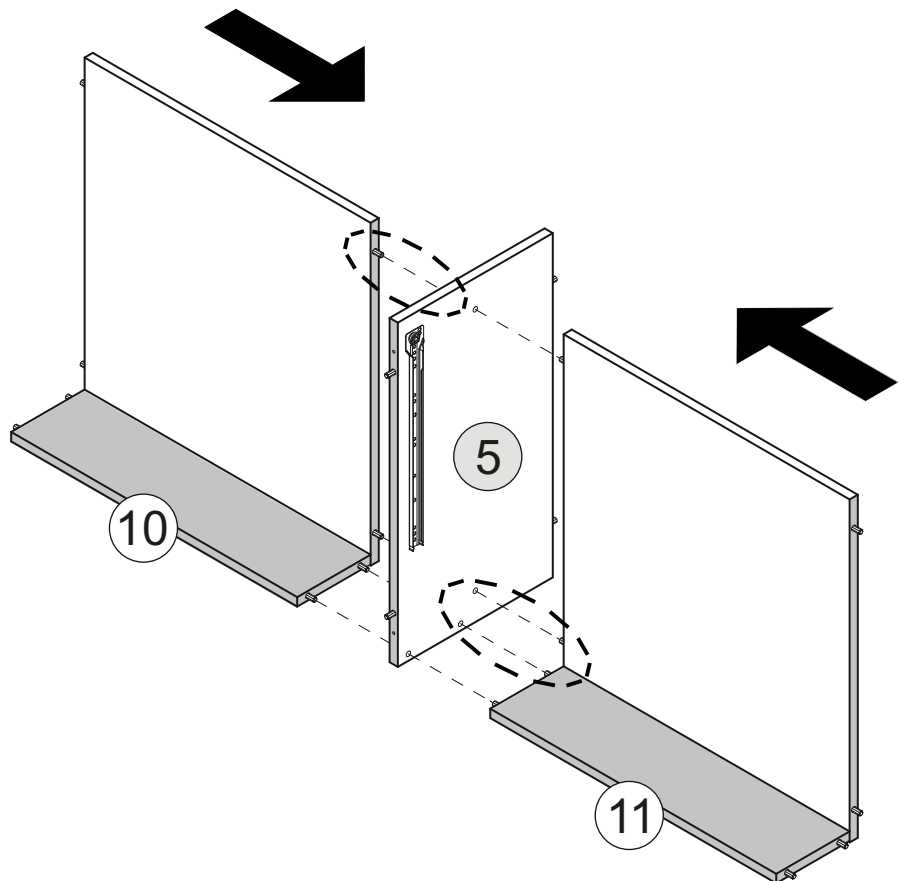

# STEP 7

PARTS REQUIRED

3 - RIGHT SIDE PANEL x1

4 - LEFT SIDE PANEL x1

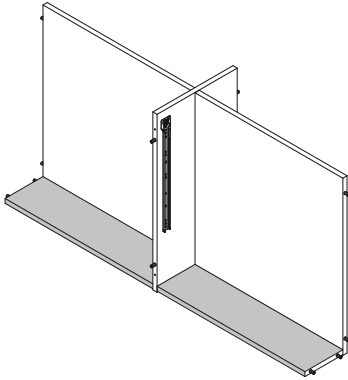

HARDWARE REQUIRED

TOOLS REQUIRED

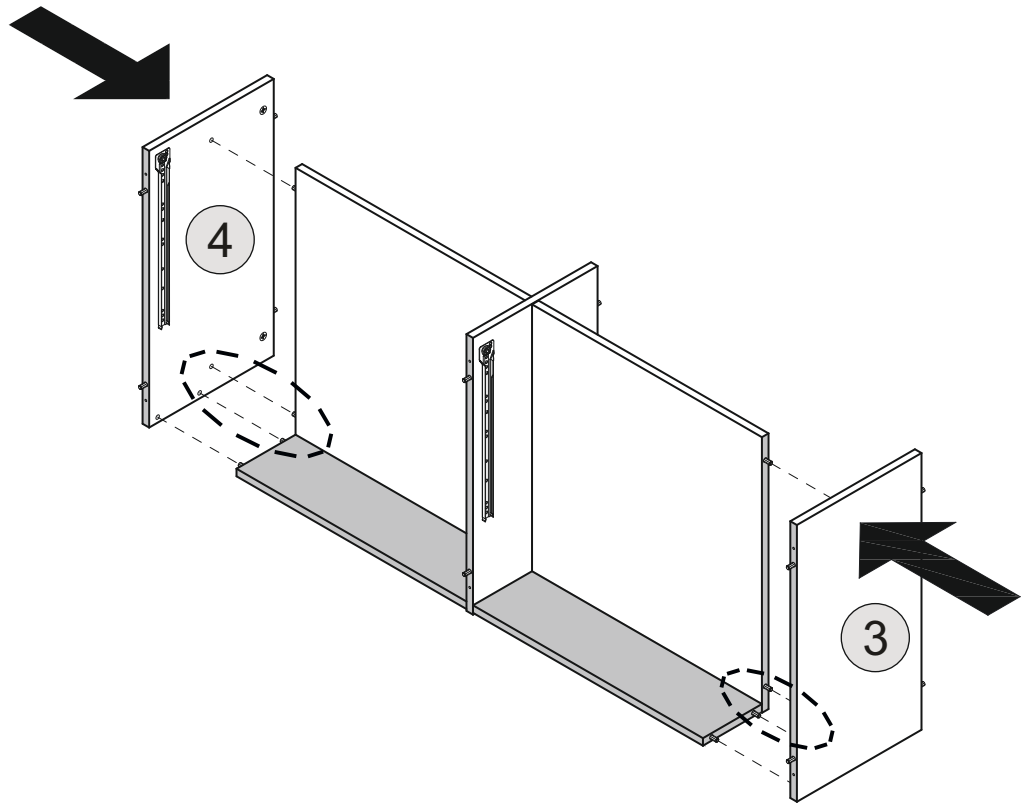

# STEP 8

PARTS REQUIRED

1 - TOP PANEL x1

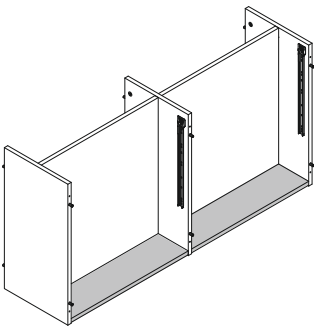

HARDWARE REQUIRED

TOOLS REQUIRED

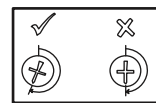
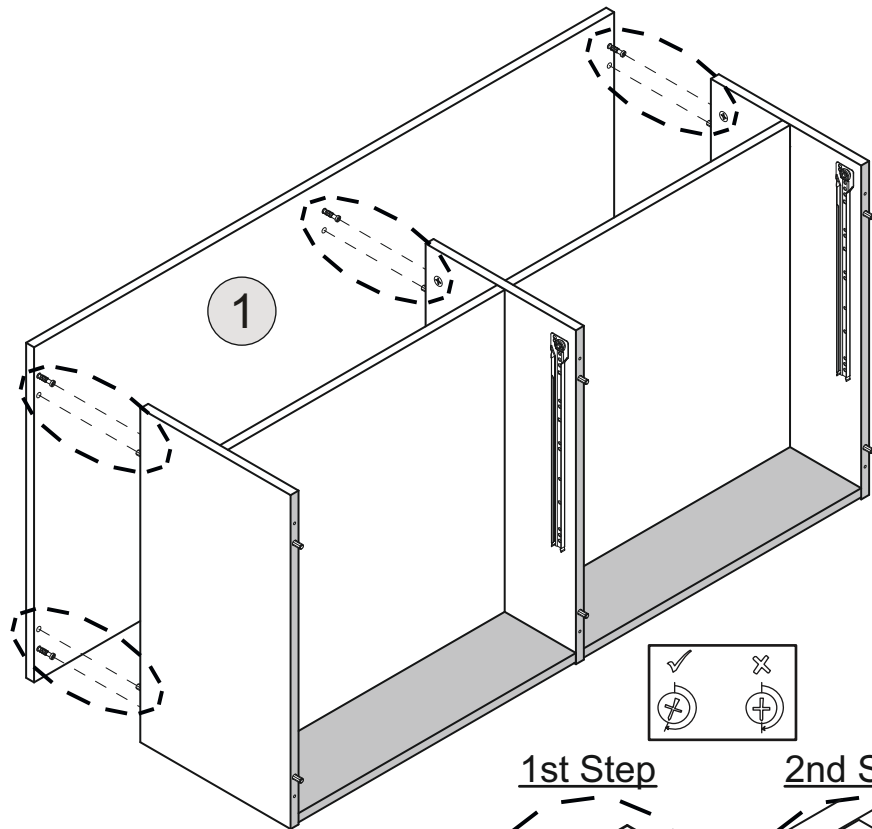
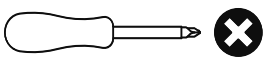

1st Step

2nd Step

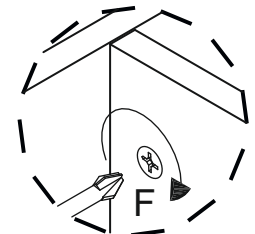
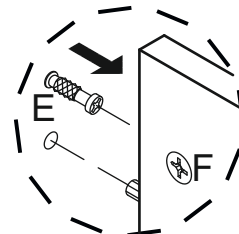

# STEP 9

PARTS REQUIRED

2 - BOTTOM PANEL x1

HARDWARE REQUIRED

H  01

N  01

O  01

TOOLS REQUIRED

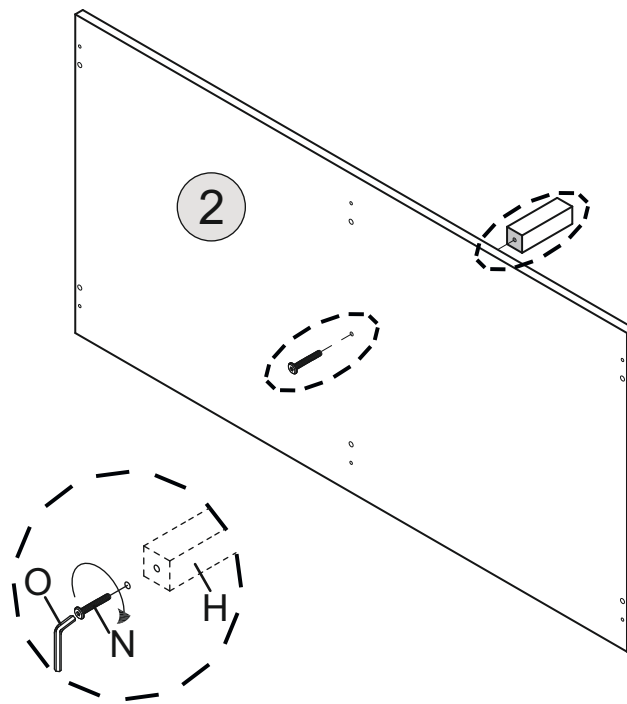
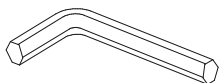

# STEP 10

PARTS REQUIRED

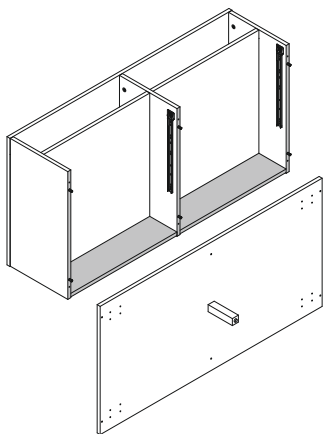

HARDWARE REQUIRED

B  06

TOOLS REQUIRED

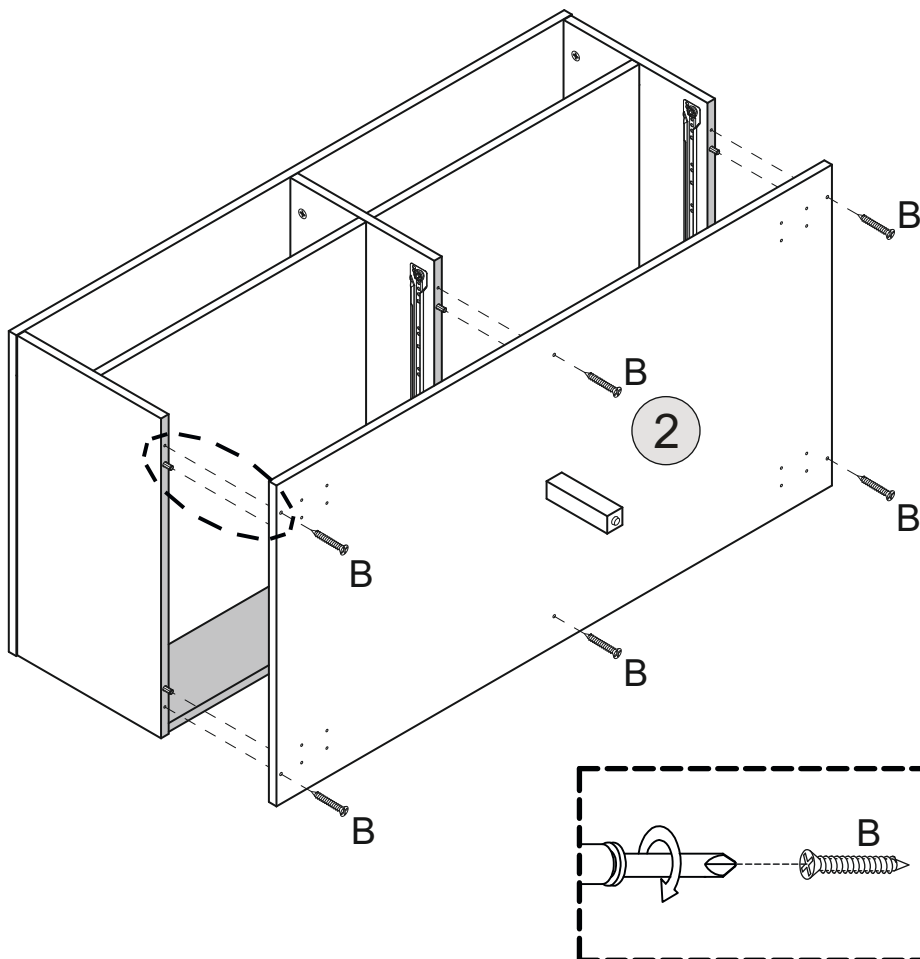
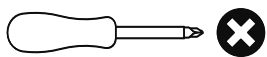



# STEP 11

**PARTS REQUIRED**

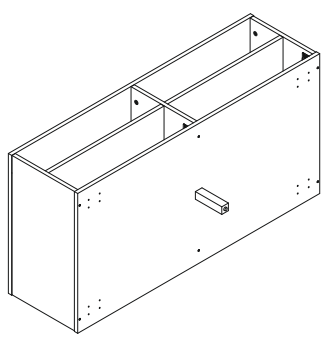

**HARDWARE REQUIRED**

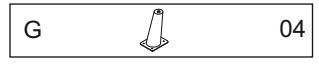
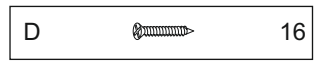

**TOOLS REQUIRED**

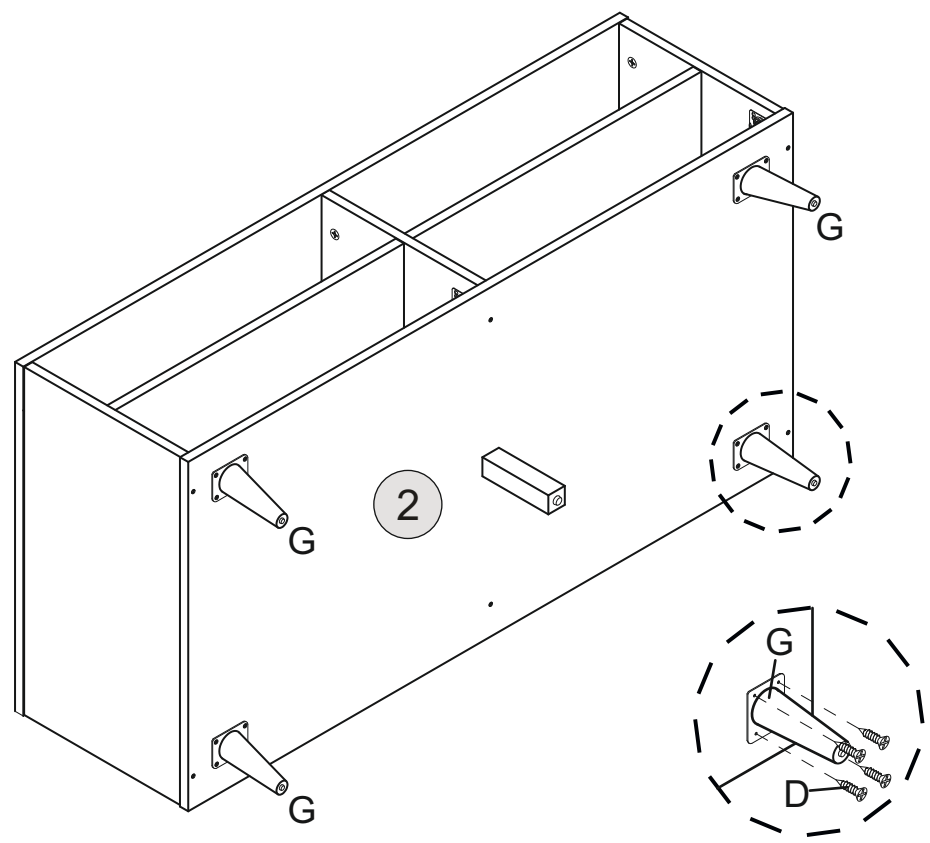
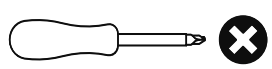

# STEP 12

**PARTS REQUIRED**

- 6 - LEFT DRAWER SIDE x2
- 7 - RIGHT DRAWER SIDE x2
- 12 - LEFT DRAWER FRONT x1
- 13 - RIGHT DRAWER FRONT x1

**HARDWARE REQUIRED**

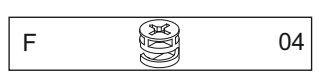
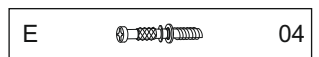
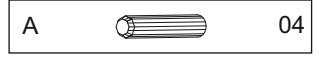

**TOOLS REQUIRED**

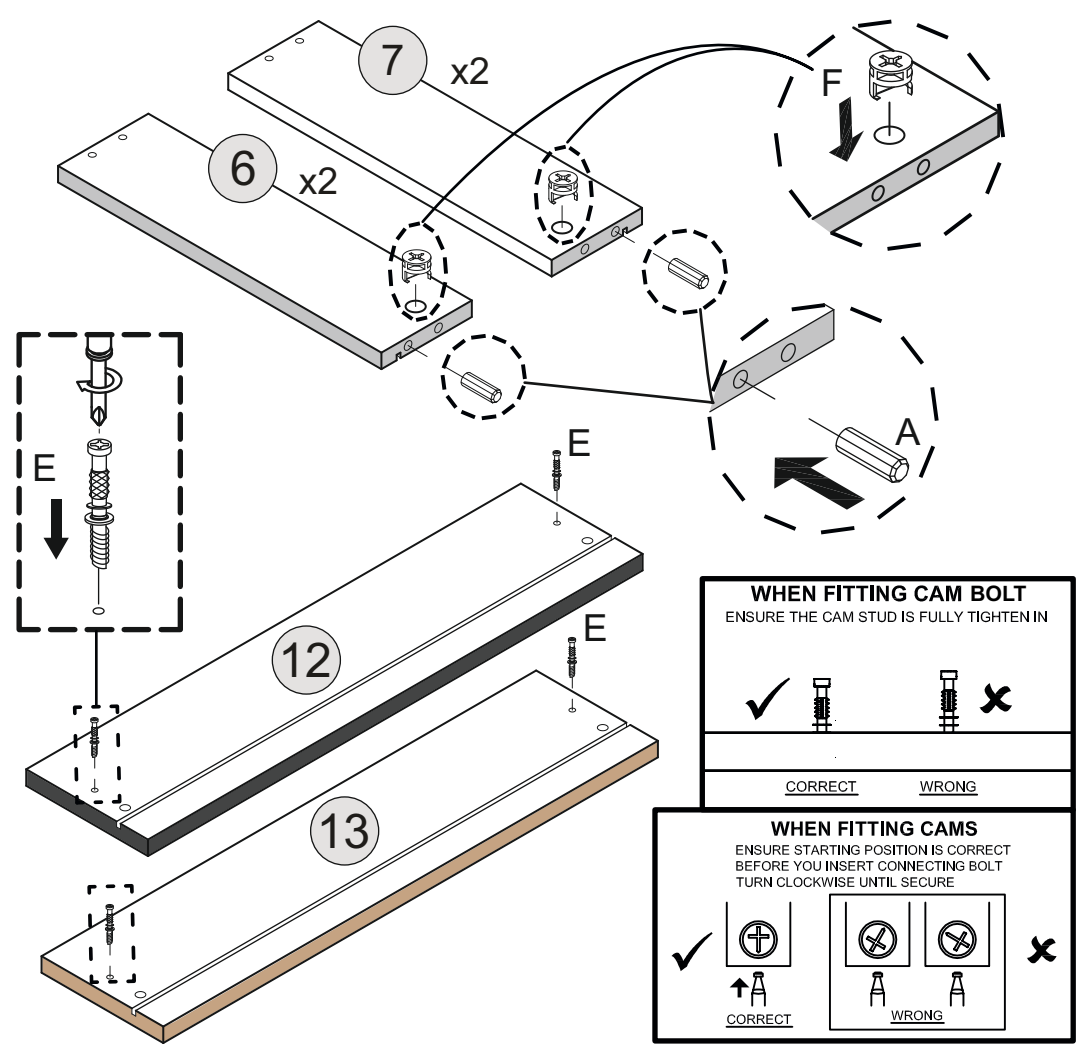
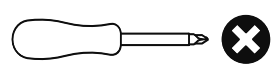

**WHEN FITTING CAM BOLT**  
ENSURE THE CAM STUD IS FULLY TIGHTEN IN

CORRECT      WRONG

**WHEN FITTING CAMS**  
ENSURE STARTING POSITION IS CORRECT BEFORE YOU INSERT CONNECTING BOLT  
TURN CLOCKWISE UNTIL SECURE

CORRECT      WRONG

# STEP 13

## PARTS REQUIRED

- 6 - LEFT DRAWER SIDE x1
- 7 - RIGHT DRAWER SIDE x1
- 9 - DRAWER BACK x1
- 12 - LEFT DRAWER FRONT x1
- 14 - DRAWER BASE x1

## HARDWARE REQUIRED

- C  04

## TOOLS REQUIRED

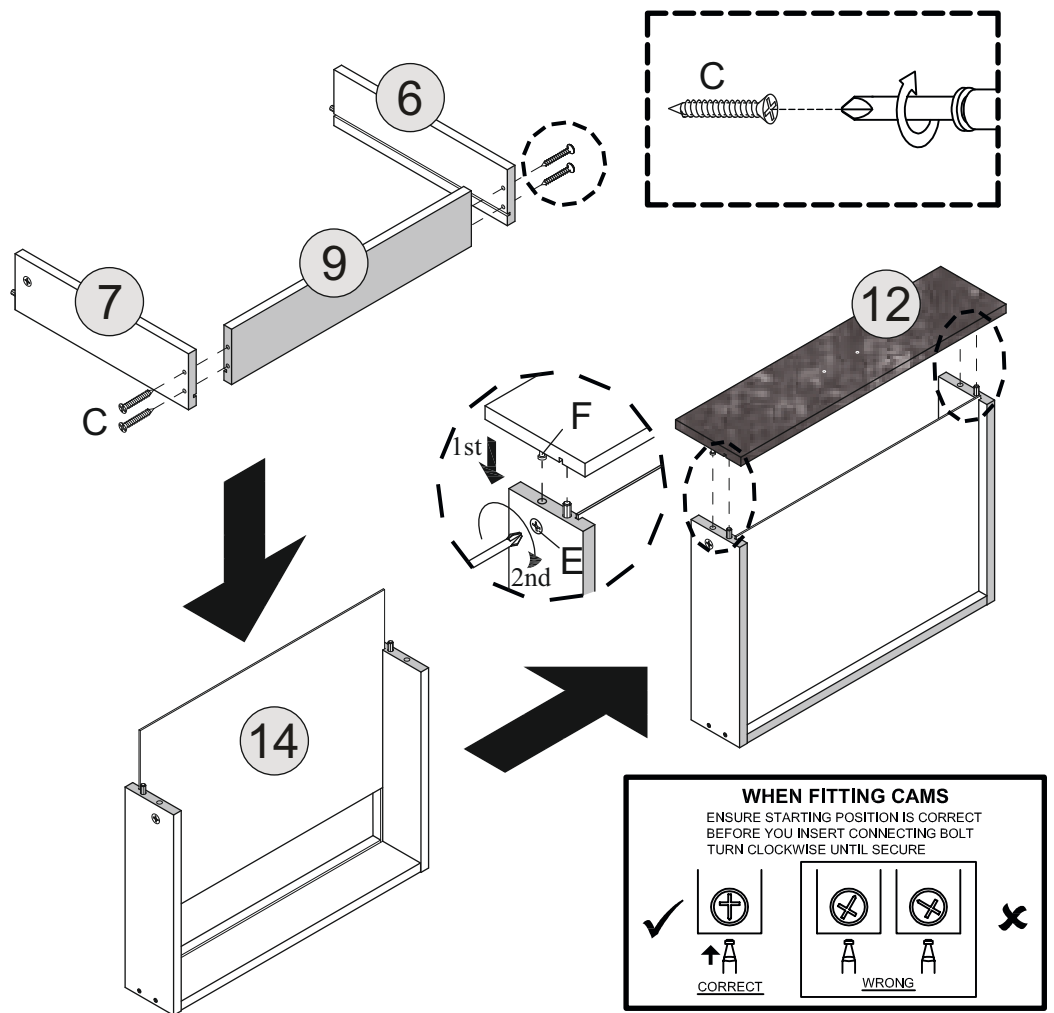
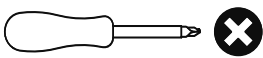

# STEP 14

## PARTS REQUIRED

- 6 - LEFT DRAWER SIDE x1
- 7 - RIGHT DRAWER SIDE x1
- 9 - DRAWER BACK x1
- 13 - RIGHT DRAWER FRONT x1
- 14 - DRAWER BASE x1

## HARDWARE REQUIRED

- C  04

## TOOLS REQUIRED

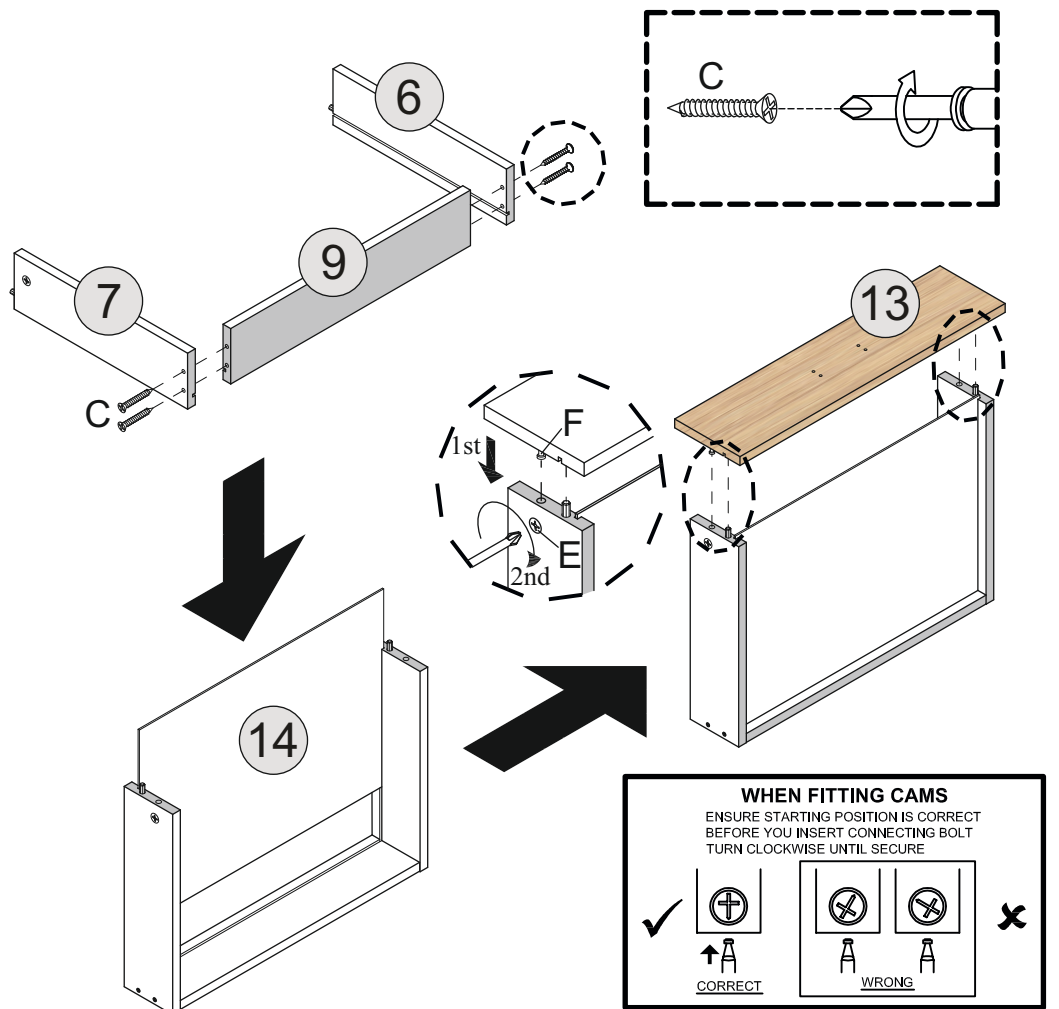
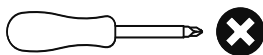



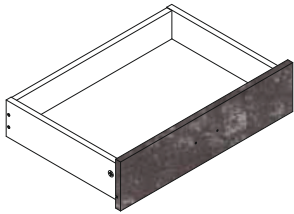

# STEP 15

PARTS REQUIRED



HARDWARE REQUIRED

- D  04
- I  01
- K  01
- L  02
- M  02

TOOLS REQUIRED

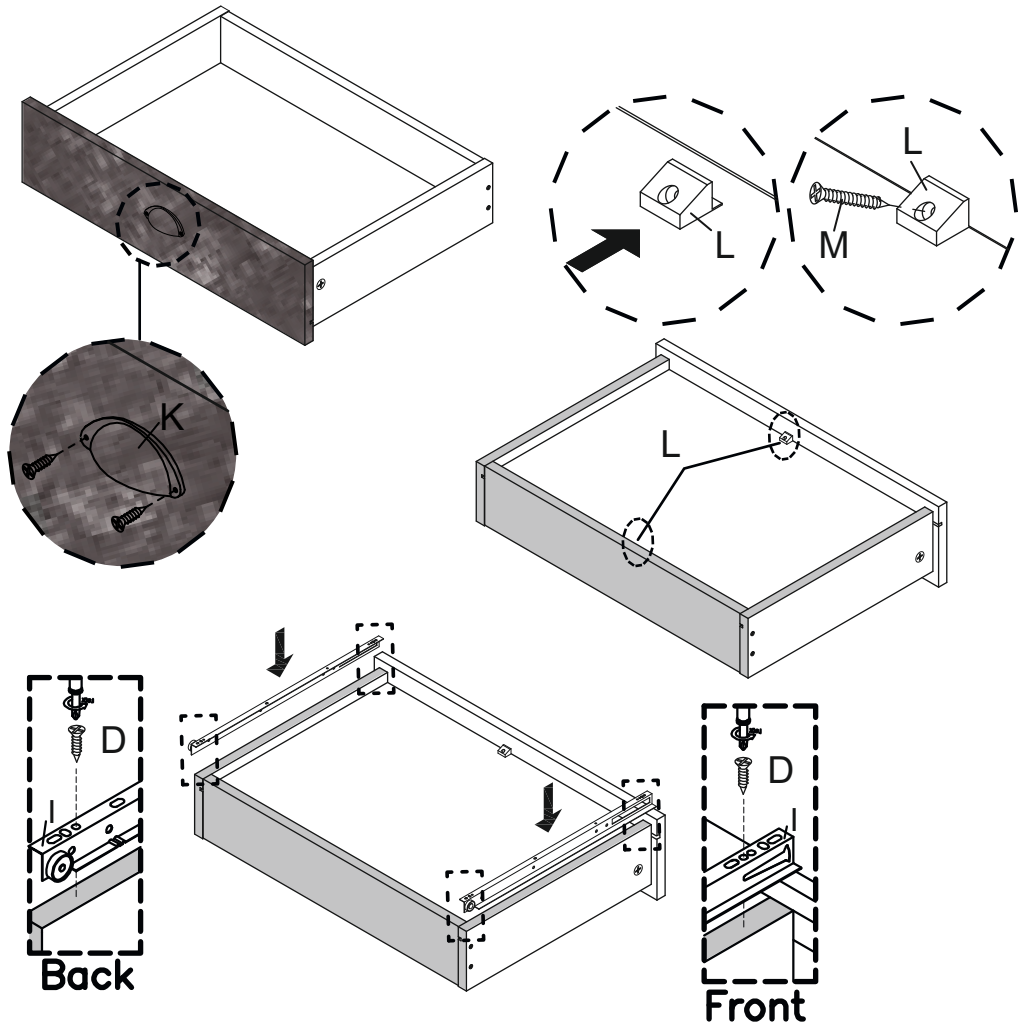
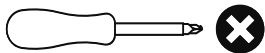



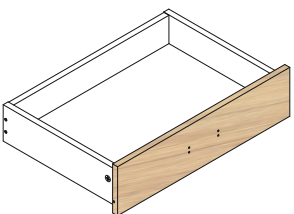

# STEP 16

PARTS REQUIRED



HARDWARE REQUIRED

- D  04
- I  01
- J  01
- L  02
- M  02

TOOLS REQUIRED

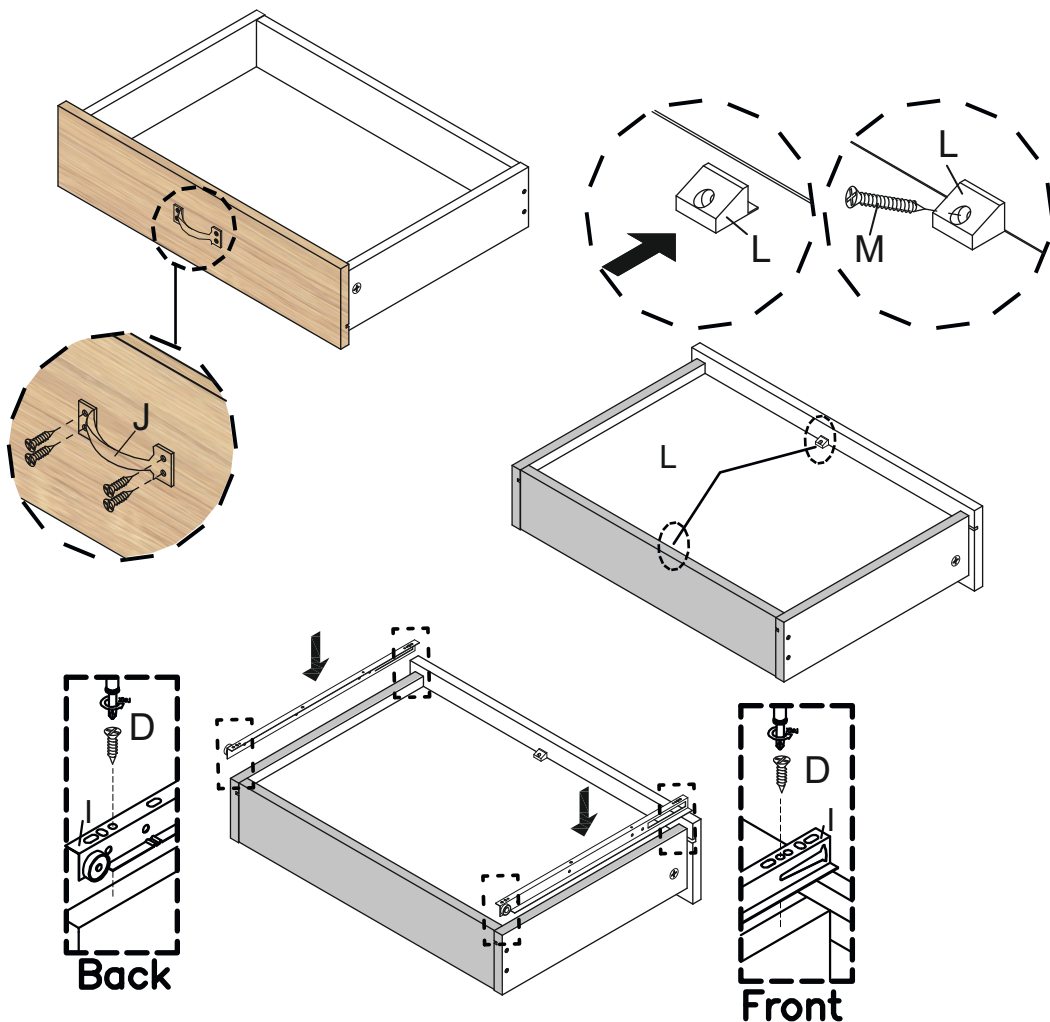
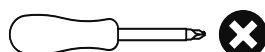

# STEP 17

PARTS REQUIRED

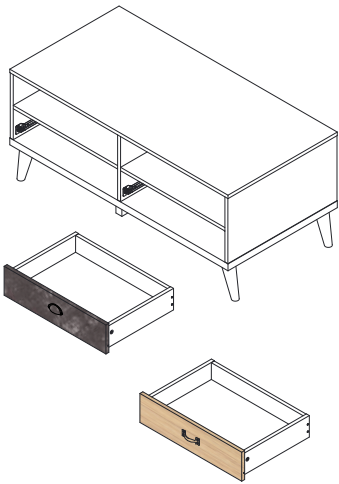

HARDWARE REQUIRED

TOOLS REQUIRED

