

NEVADA MIRRORED 2 DOOR WARDROBE ASSEMBLY INSTRUCTIONS

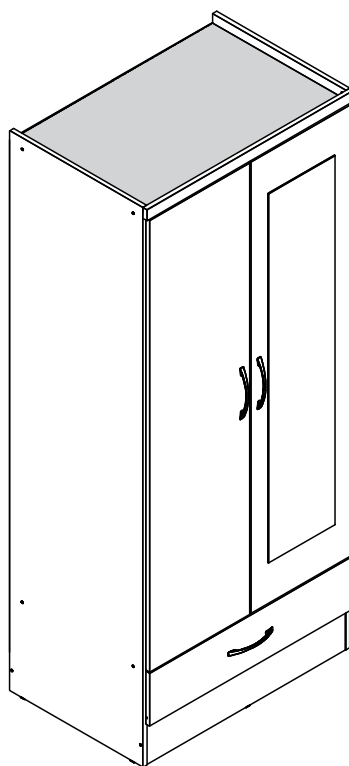

IMPORTANT FOR DOMESTIC USE ONLY

PLEASE READ BEFORE YOU CONTINUE FURTHER

CARE AND MAINTENANCE

After unpacking this product please keep the original packaging in case it needs to be returned for any reason.

- Please ensure all fittings and parts are present before commencing with assembly.
- Never drag or push products as this could cause damage to the joints making it inferior.
- We strongly recommend that you keep children away from your work area.
- We recommend that you lay a blanket or sheet on the floor to avoid damage to both your floor and the product.
- Assemble this product as close to its final position as possible.
- Do not place this product next to a radiator or in direct sunlight.
- Do not drag or push items across your high gloss furniture as this may cause the surface to scratch
- Wood is a natural product and may expand if subjected to damp and may shrink or crack if subjected to heat. Therefore it is recommended that room temperature is maintained, with no sudden temperature fluctuations.
- Make sure any spillage is wiped off immediately.
- Do not place hot or chilled items directly on to the surface, use a place mat or marking will occur.
- For general cleaning use a soft cotton or micro fibre cloth, and do not use detergents of any kind.
- From time to time it may be necessary to tighten fittings, regular inspections should be carried out.
- Do not place on a wet or damp floor as staining may occur to your floor.

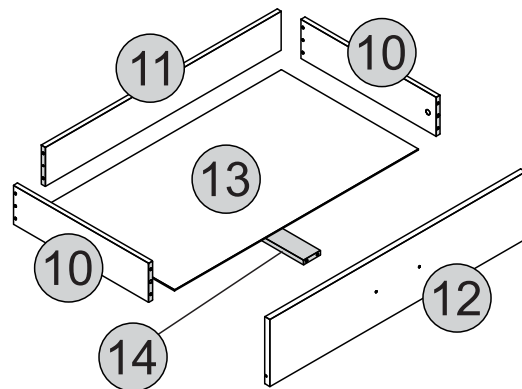
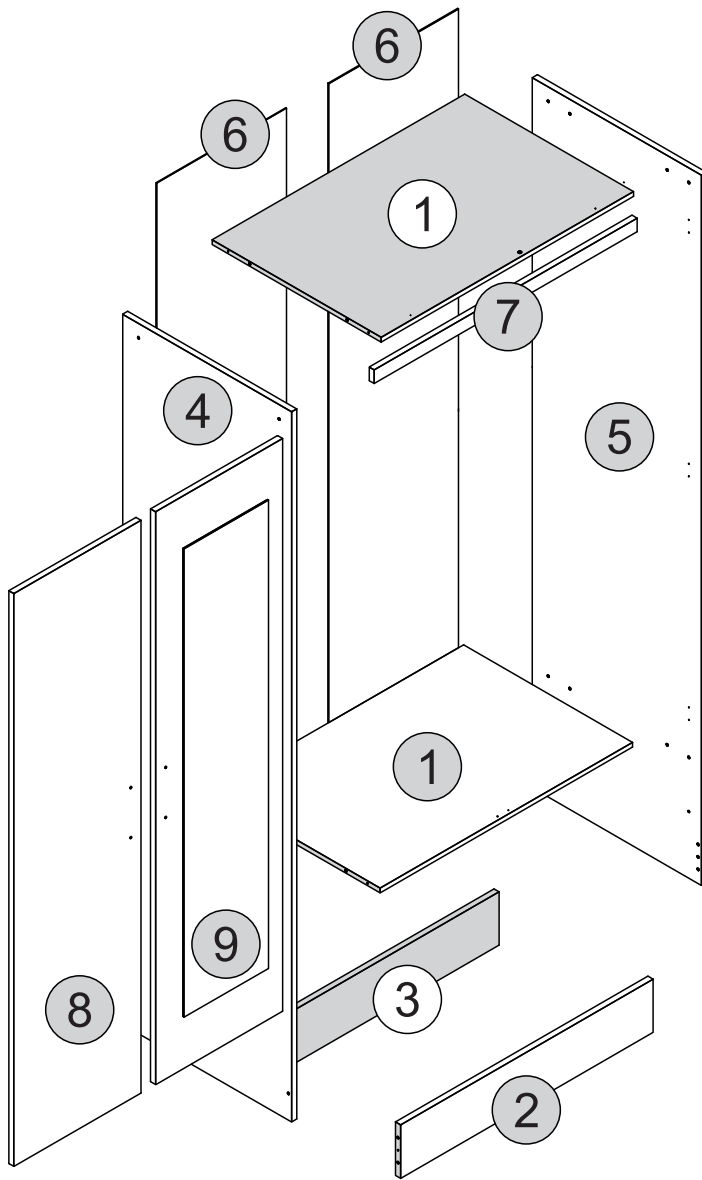

After assembly use an alcohol based product/cleaner to erase the numbers printed on the parts that are visual.

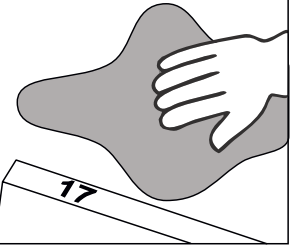

PARTS LIST

Please Note:







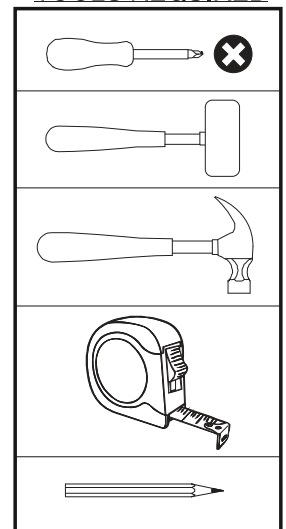

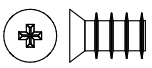
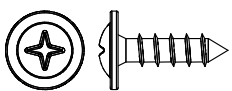
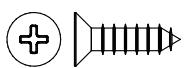
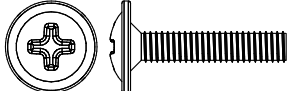
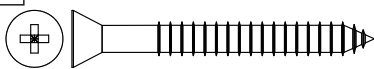
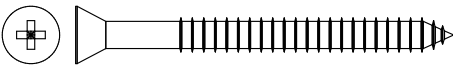

The below parts have all been stamped with the part number to help identify them during assembly.

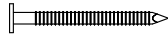
Part Number	Part Description	Quantity	Carton
01	Base-Top Panel	2	1/2
02	Front Baseboard	1	2/2
03	Back Baseboard	1	2/2
04	Left Side Panel	1	1/2
05	Right Side Panel	1	1/2
06	Back Panel	2	1/2
07	Frame	1	2/2
08	Door	1	2/2
09	Mirrored Door	1	2/2
10	Drawer Side	2	1/2
11	Drawer Back Panel	1	2/2
12	Drawer Front	1	2/2
13	Drawer Botom	1	1/2
14	Drawer Botom Support Bar	1	2/2

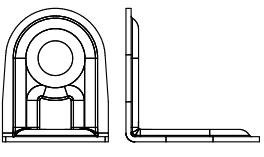
TOOLS REQUIRED

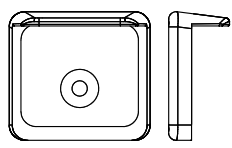
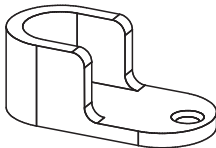
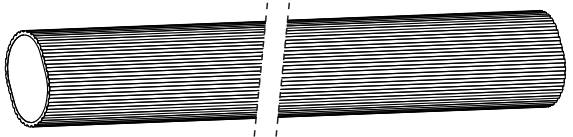
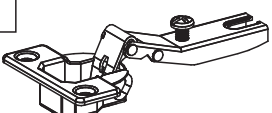
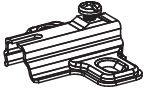
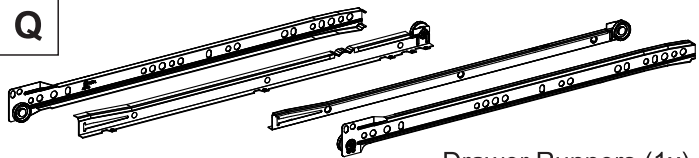
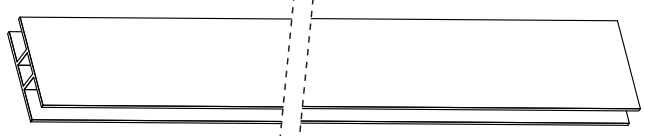

FITTINGS LIST

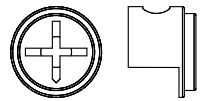
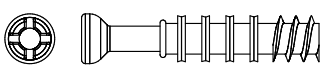
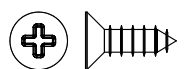
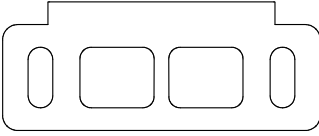
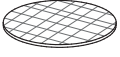
<p>A</p>  <p>Flat Head Screw Ø6,0 x 10mm (4x)</p> <p>1/+</p>	<p>B</p>  <p>Flan Head Screw Ø4,0 x 14mm (6x)</p> <p>1/+</p>	<p>C</p>  <p>Flat Head Screw Ø4,0 x 14mm (34x)</p> <p>2/+</p>	<p>D</p>  <p>Flan Head Screw Ø4,0 x 20mm (6x)</p> <p>1/+</p>
<p>E</p>  <p>Flat Head Screw Ø3,5 x 40mm (2x)</p> <p>1/+</p>	<p>F</p>  <p>Flat Head Screw Ø4,0 x 50mm (14x)</p> <p>2/+</p>	<p>G</p>  <p>2/+ Dowel Ø6,0 x 30mm (26x)</p>	
<p>H</p>  <p>2/+ Nail 10 x 10 (58x)</p>	<p>I</p>  <p>1/+ Flan Head Screw Ø3,5 x 30mm (2x)</p>	<p>J</p>  <p>1/+ 'L' Metallic Support (4x)</p>	<p>K</p>  <p>1/+ Washer (4x)</p>
<p>L</p>  <p>Plastic Foot (6x)</p>	<p>M</p>  <p>Hanging Rail Support (2x)</p>	<p>N</p>  <p>Hanging Rail (1x)</p>	
<p>O</p>  <p>Hinge (6x)</p>	<p>P</p>  <p>Hinge Plate (6x)</p>	<p>Q</p>  <p>Drawer Runners (1x)</p>	
<p>R</p>  <p>Back Panel Strip (1x)</p>		<p>S</p>  <p>Strap (2x)</p>	<p>T</p>  <p>Handle (3x)</p>
<p>U</p>  <p>2/+ Hole Plugs (12x)</p>	<p>V</p>  <p>Glue (1x)</p>	<p>W</p>  <p>1/+ Cam Nut (2x)</p>	<p>X</p>  <p>1/+ Cam Bolt (2x)</p>
<p>Y</p>  <p>2/+ Flat Head Screw Ø4,0 x 12mm (12x)</p>	<p>Z</p>  <p>Door Support (2x)</p>		<p>A1</p>  <p>2/+ Hole Plugs (2x)</p>

TIPS FOR FITTINGS CAM-LOCKS

WHEN FITTING CAM NUT. ENSURE STARTING POSITION IS CORRECT BEFORE YOU INSERT CONNECTING CAM BOLT TURN CLOCKWISE UNTIL SECURE

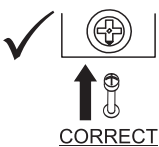

✓

↑

CORRECT

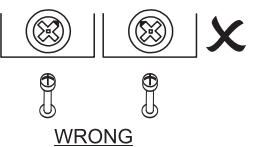

✗

WRONG

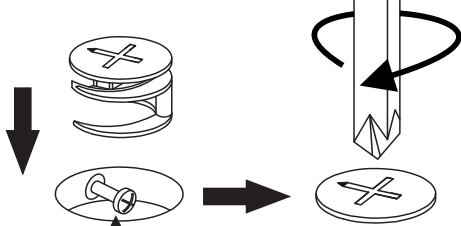

Cam bolt head needs to be in centre

CAMBOLT
Tighten until shoulder in flush with panel. Do not overtighten or undertighten (see example beside)

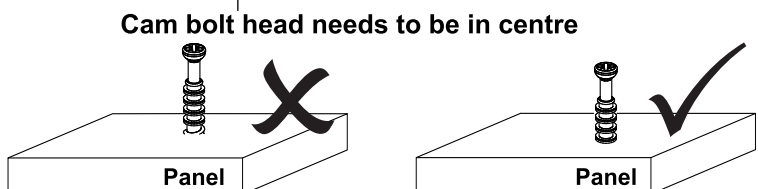
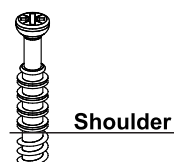



STEP 1

PARTS REQUIRED

4 - LEFT SIDE PANEL x1

HARDWARE REQUIRED

A  02
Ø6,0 x 10mm

H  02
10 x 10

L  02

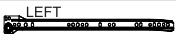
Q  01

TOOLS REQUIRED

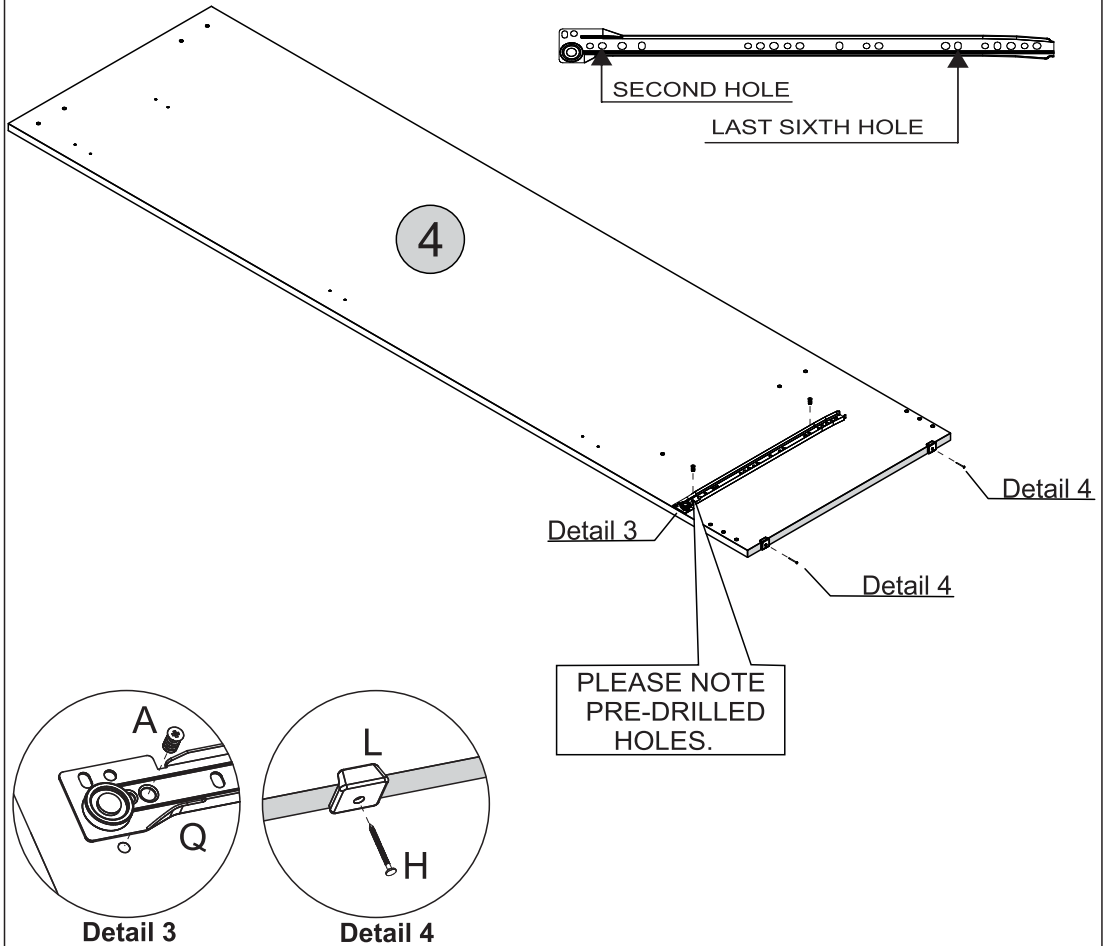
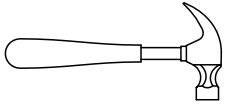
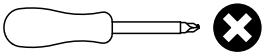



STEP 2

PARTS REQUIRED

5 - RIGHT SIDE PANEL x1

HARDWARE REQUIRED

A  02
Ø6,0 x 10mm

H  02
10 x 10

L  02

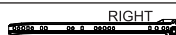
Q  01

TOOLS REQUIRED

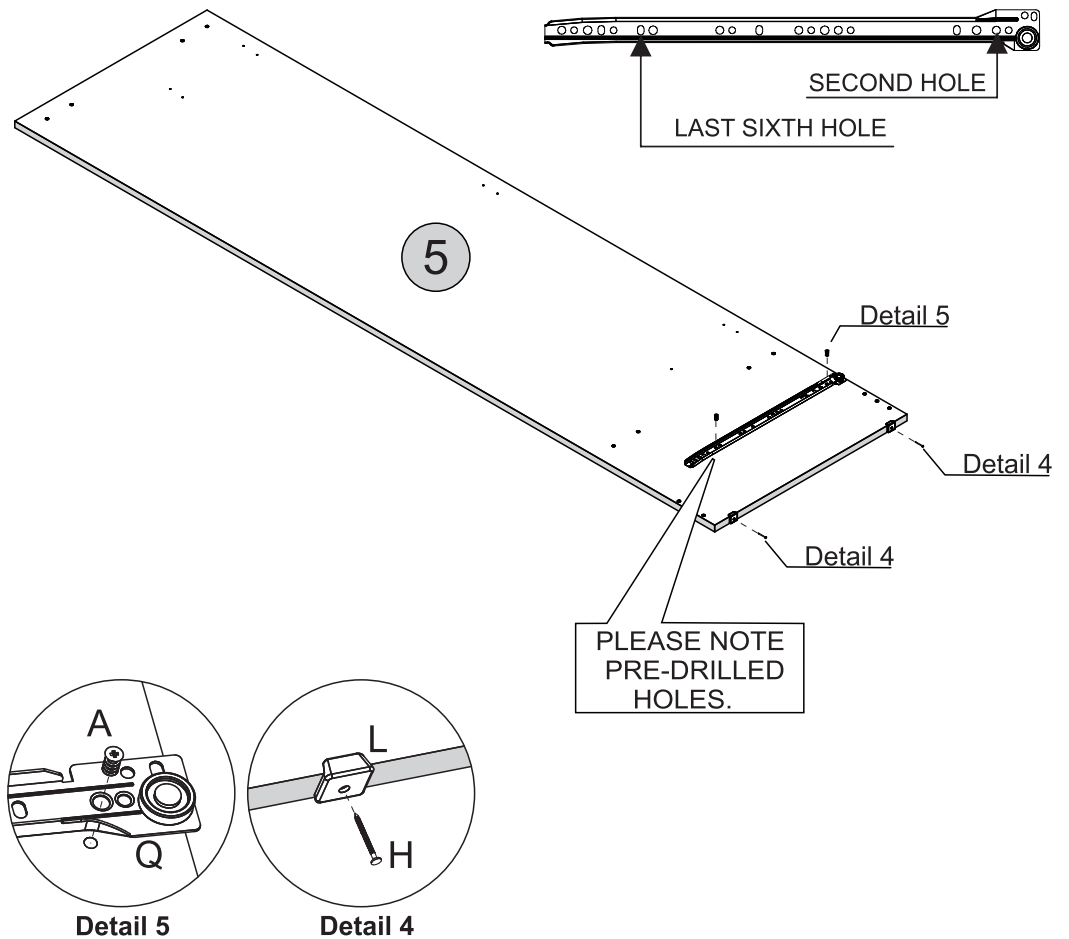
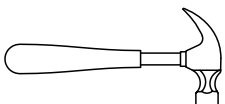
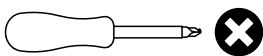

STEP 3

PARTS REQUIRED

4 - LEFT SIDE PANEL x1

HARDWARE REQUIRED

C  08
Ø4,0 x 14mm

M  01

P  03

TOOLS REQUIRED

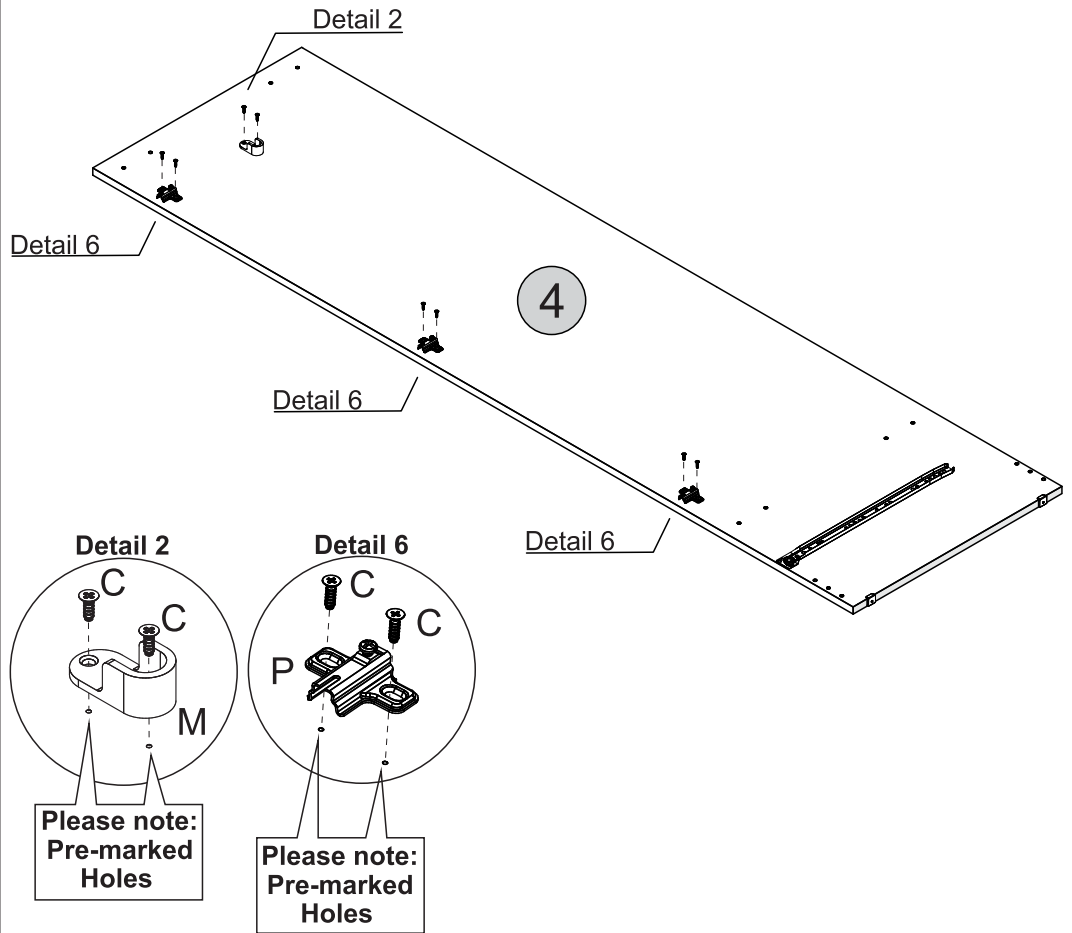
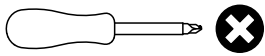



STEP 4

PARTS REQUIRED

5 - RIGHT SIDE PANEL x1

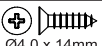
HARDWARE REQUIRED

C  08
Ø4,0 x 14mm

M  01

P  03

TOOLS REQUIRED

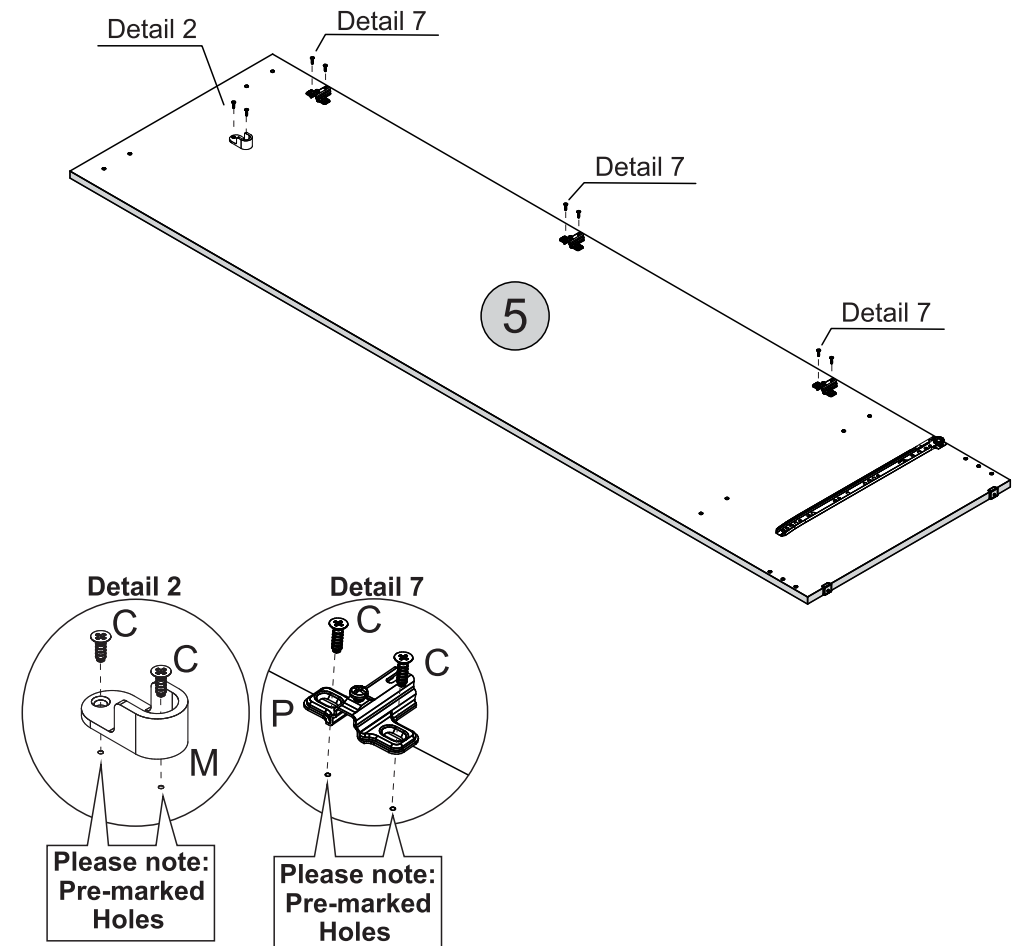
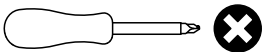

STEP 5

PARTS REQUIRED

1A - BASE PANEL x1

1B - TOP PANEL x1

HARDWARE REQUIRED

G  08
Ø6,0 x 30mm

J  02

V  01

Y  06
Ø4,0 x 12mm

Z  02

TOOLS REQUIRED

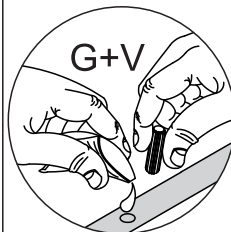
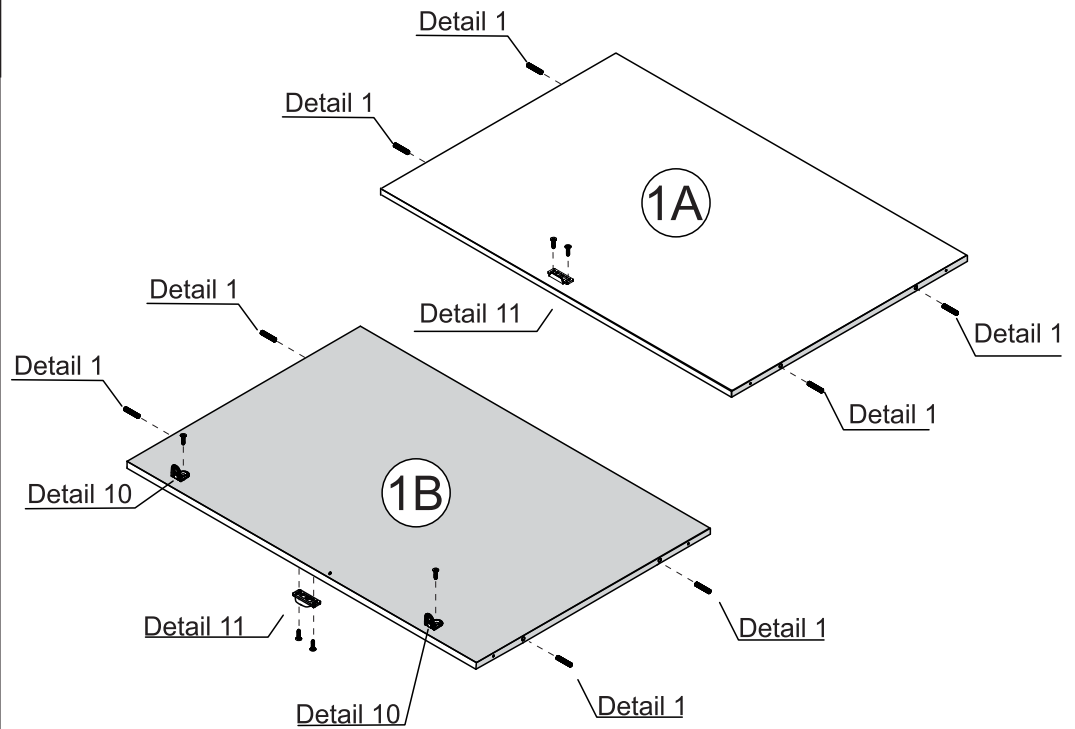
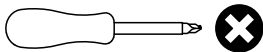

Detail 1

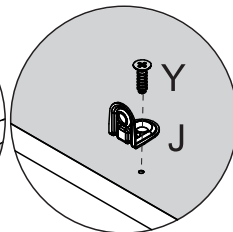

Detail 10

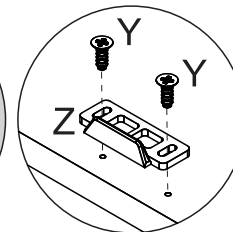

Detail 11

STEP 6

PARTS REQUIRED

2 - FRONT BASEBOARD x1

3 - BACK BASEBOARD x1

HARDWARE REQUIRED

G  08
Ø6,0 x 30mm

H  02
10 x 10

L  02

V  01

TOOLS REQUIRED

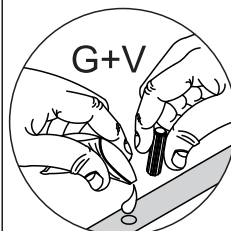
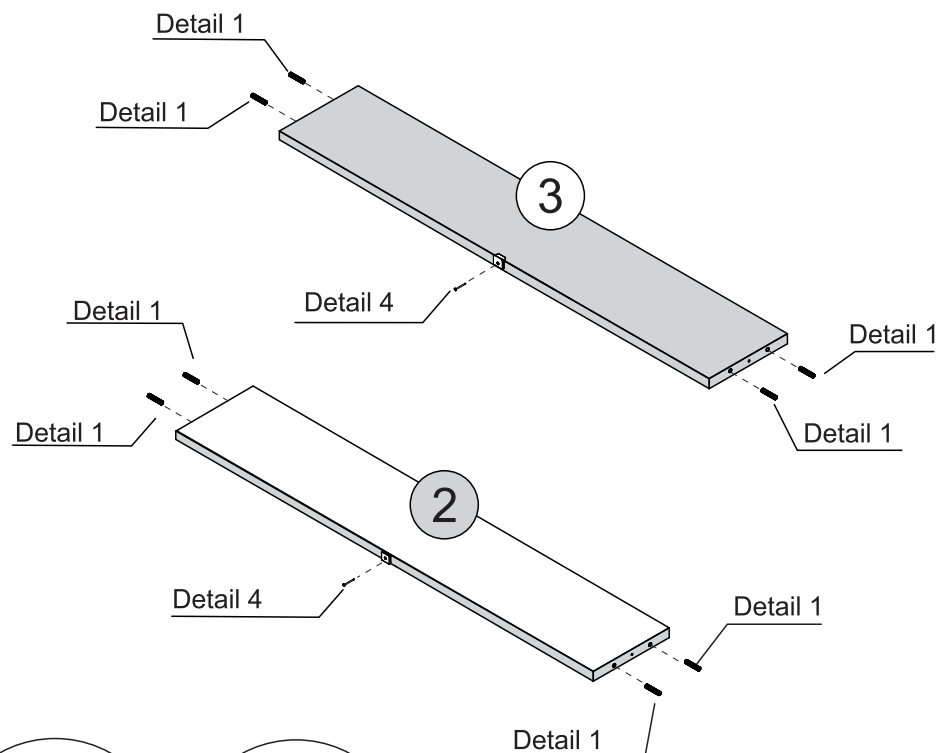
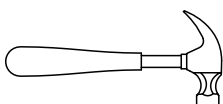

Detail 1

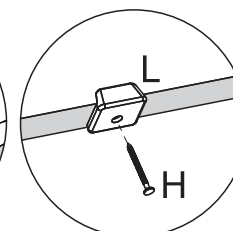

Detail 4

STEP 7

PARTS REQUIRED

1A - BASE PANEL x1

1B - TOP PANEL x1

5 - RIGHT SIDE PANEL x1

HARDWARE REQUIRED

F  04
Ø4,0 x 50mm

V  01

TOOLS REQUIRED

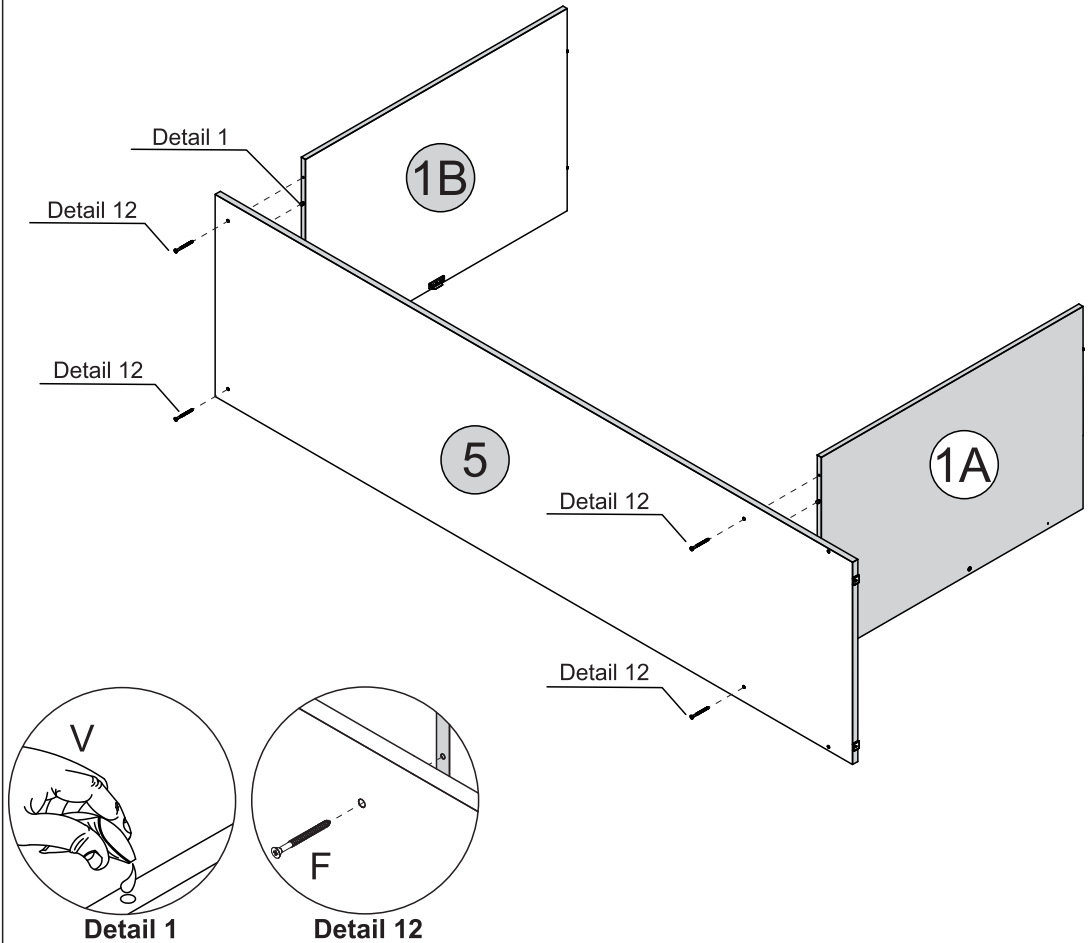
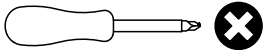

STEP 8

PARTS REQUIRED

2 - FRONT BASEBOARD x1

3 - BACK BASEBOARD x1

4 - LEFT SIDE PANEL x1

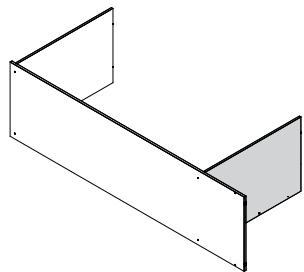

HARDWARE REQUIRED

F  08
Ø4,0 x 50mm

V  01

TOOLS REQUIRED

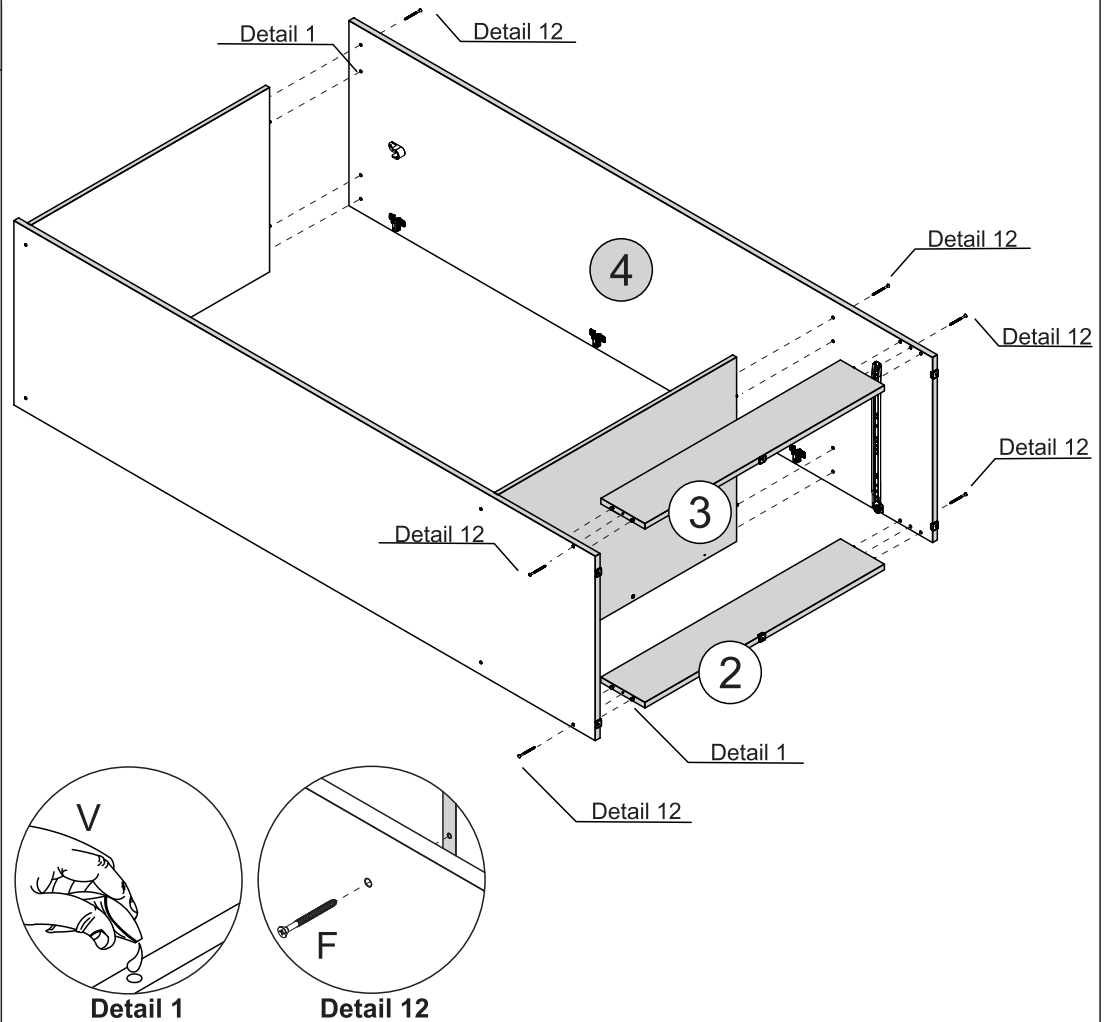
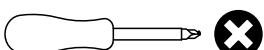

STEP 9

PARTS REQUIRED

6 - BACK PANEL x2

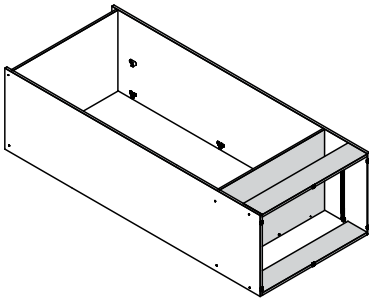

HARDWARE REQUIRED

B  06
Ø4,0 x 14mm

H  06
10 x 10

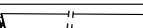
R  01

TOOLS REQUIRED

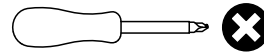
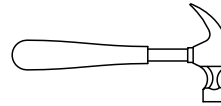

IMPORTANT PLEASE FOLLOW !

Please make sure Part 6 is lined up correctly at the top before placing fitting H into the panel as this can affect the alignment of the doors once assembled.

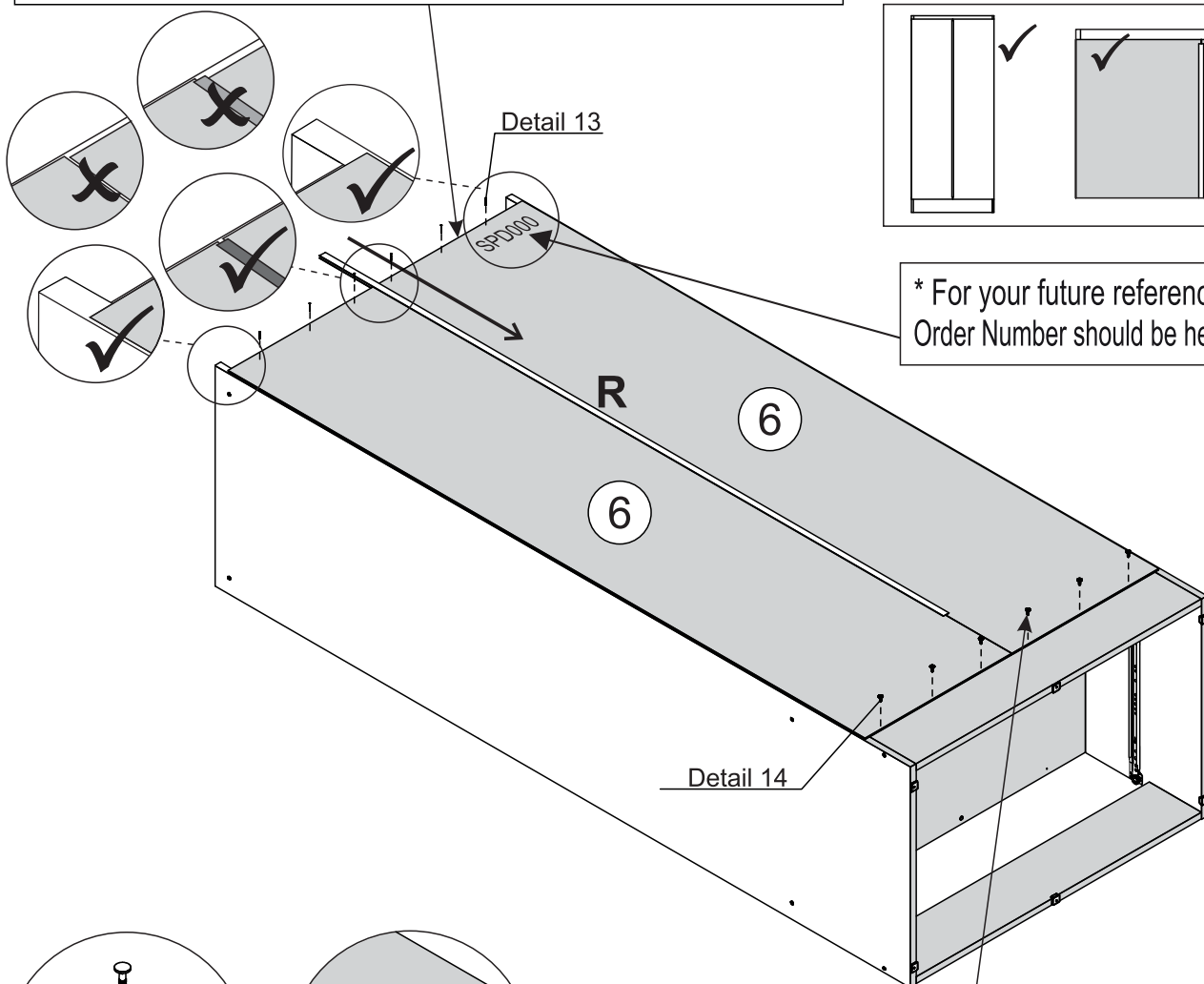
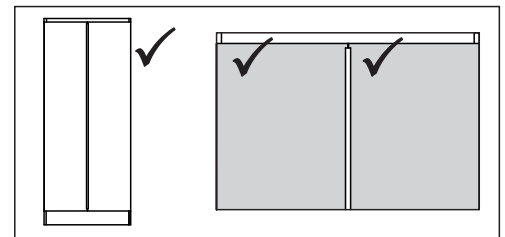
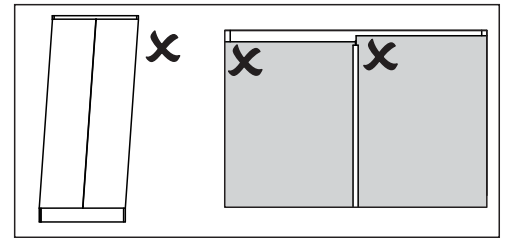

* For your future reference Order Number should be here

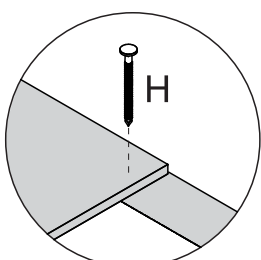

Detail 13

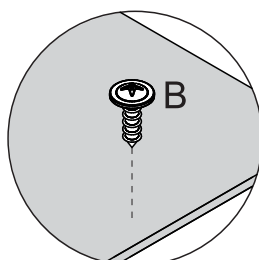

Detail 14

IMPORTANT PLEASE FOLLOW !

Please make sure Part 6 isn't overhanging at the sides before you screw fitting B into the plinth.

STEP 10

PARTS REQUIRED

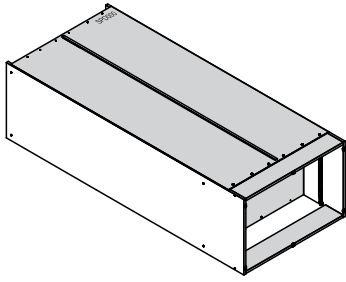

HARDWARE REQUIRED

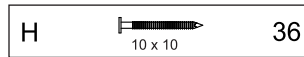

TOOLS REQUIRED

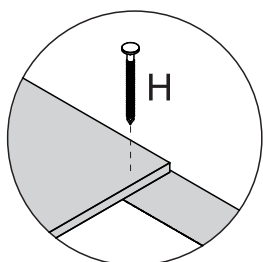
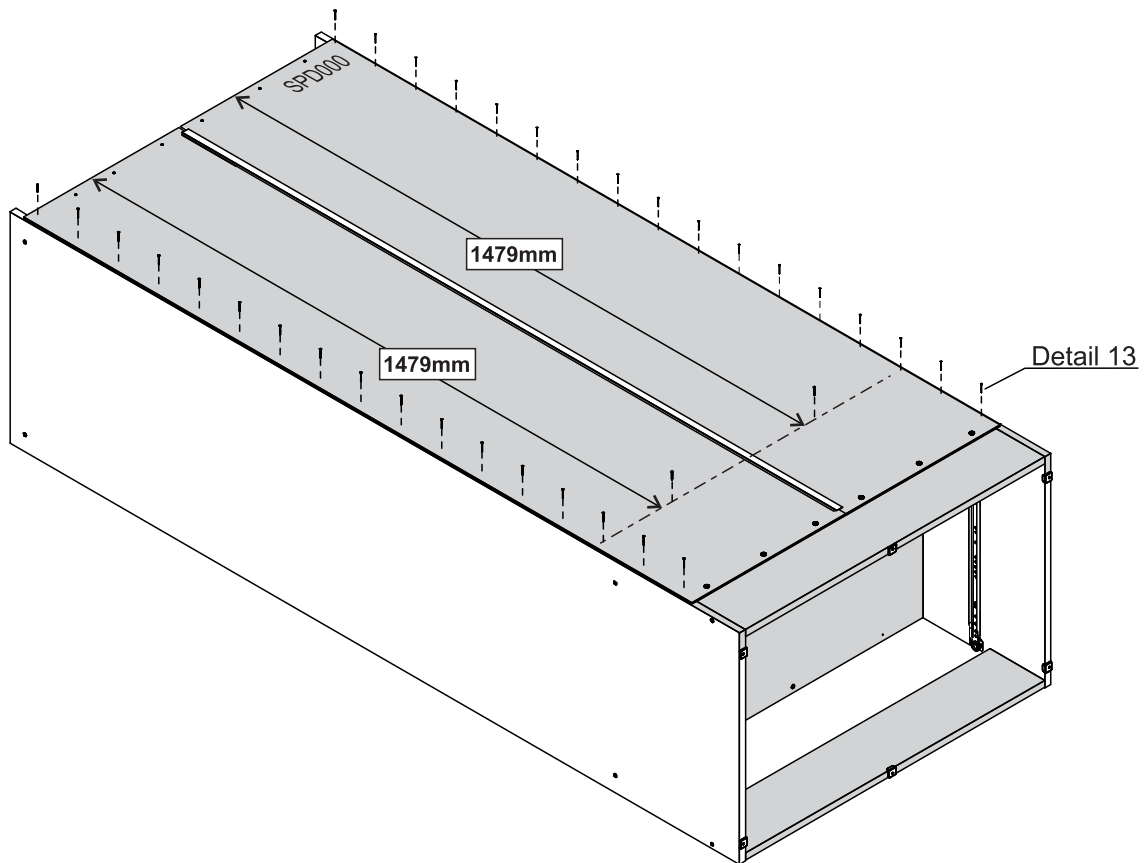
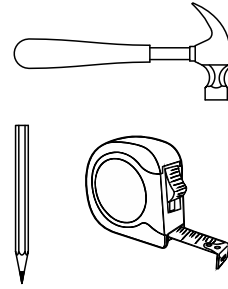

Detail 13

STEP 11

PARTS REQUIRED

7 - FRAME x1

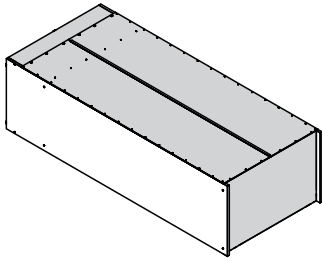

HARDWARE REQUIRED

J  02

Y  Ø4,0 x 12mm 06

TOOLS REQUIRED

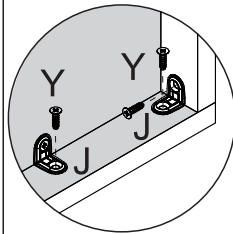
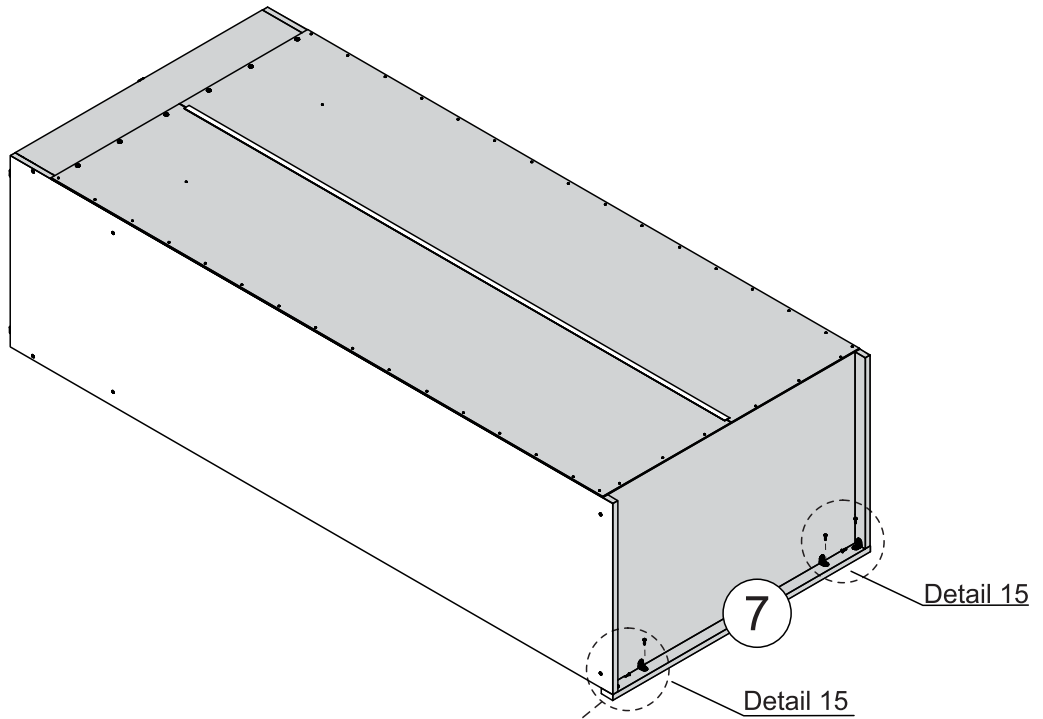
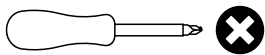

Detail 15

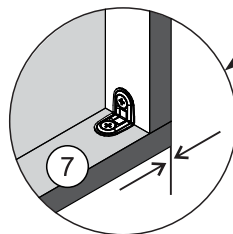

Align corners

STEP 12

PARTS REQUIRED

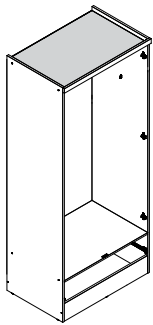

HARDWARE REQUIRED

N  01

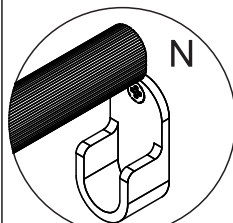
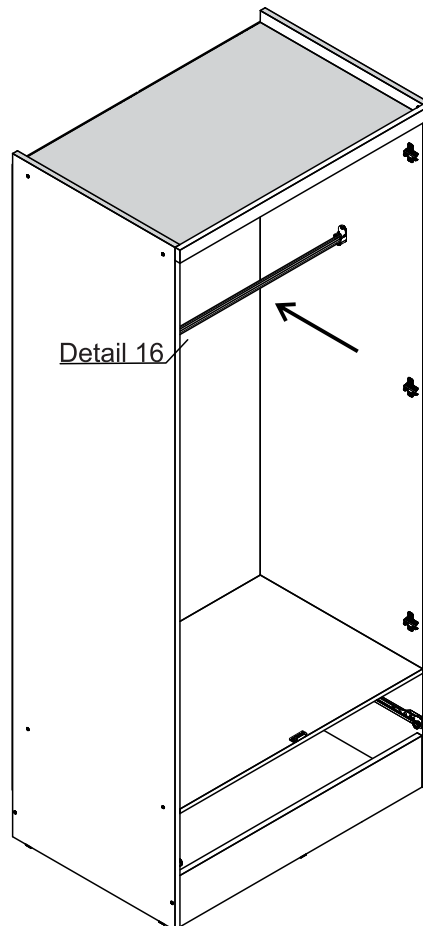

Detail 16

STEP 13

PARTS REQUIRED

10 - DRAWER SIDE x2

11 - DRAWER BACK PANEL x1

14 - DRAWER BOTTOM SUPPORT BAR x1

HARDWARE REQUIRED

G  10
Ø6,0 x 30mm

V  01

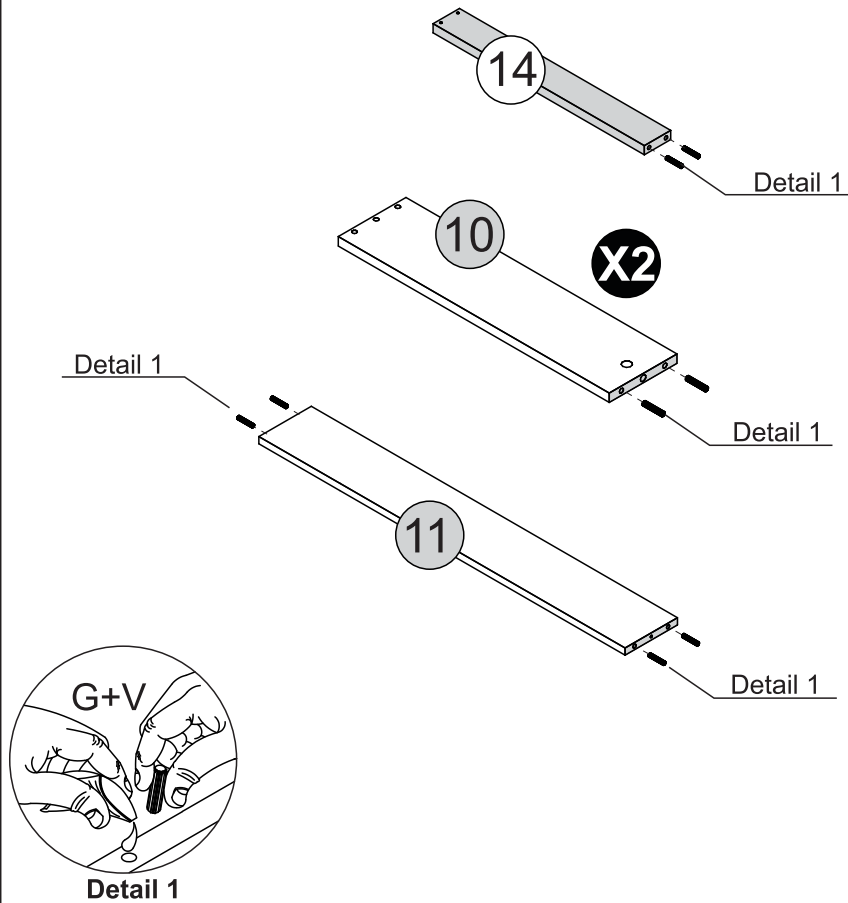

STEP 14

PARTS REQUIRED

12 - DRAWER FRONT x1

HARDWARE REQUIRED

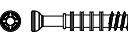
X  02

TOOLS REQUIRED

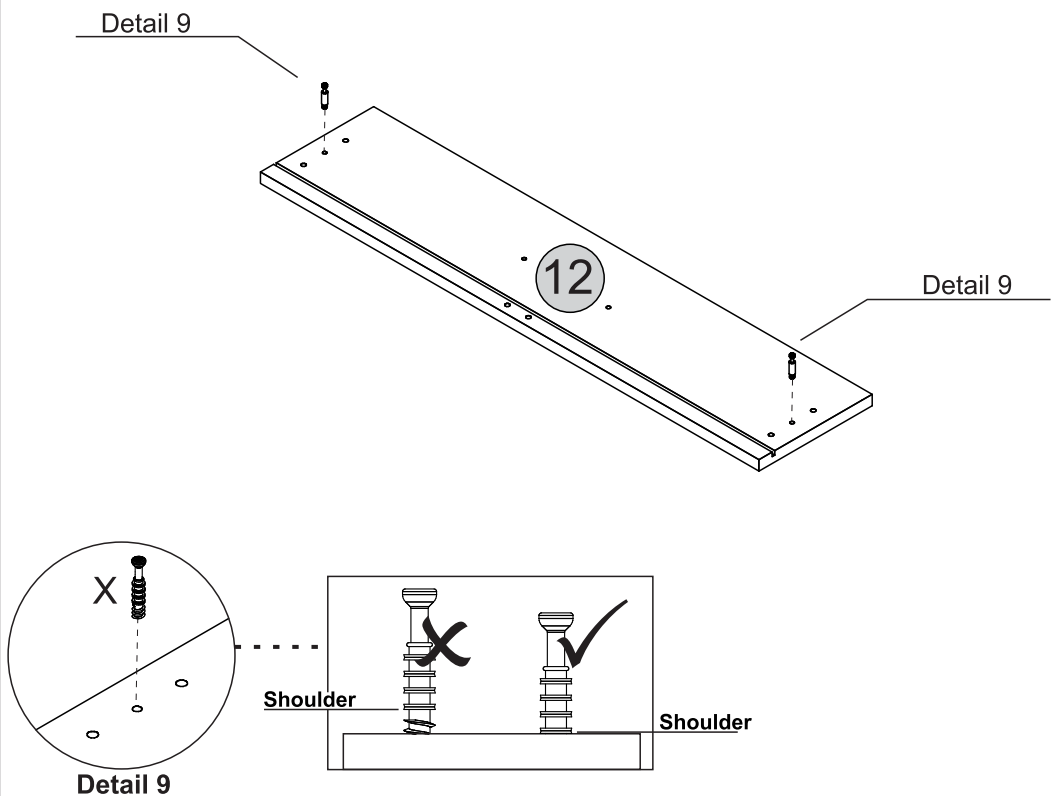
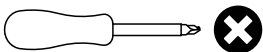

STEP 15

PARTS REQUIRED

10 - DRAWER SIDE x2

11 - DRAWER BACK PANEL x1

HARDWARE REQUIRED

F  02
Ø4,0 x 50mm

TOOLS REQUIRED

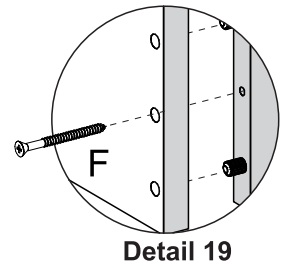
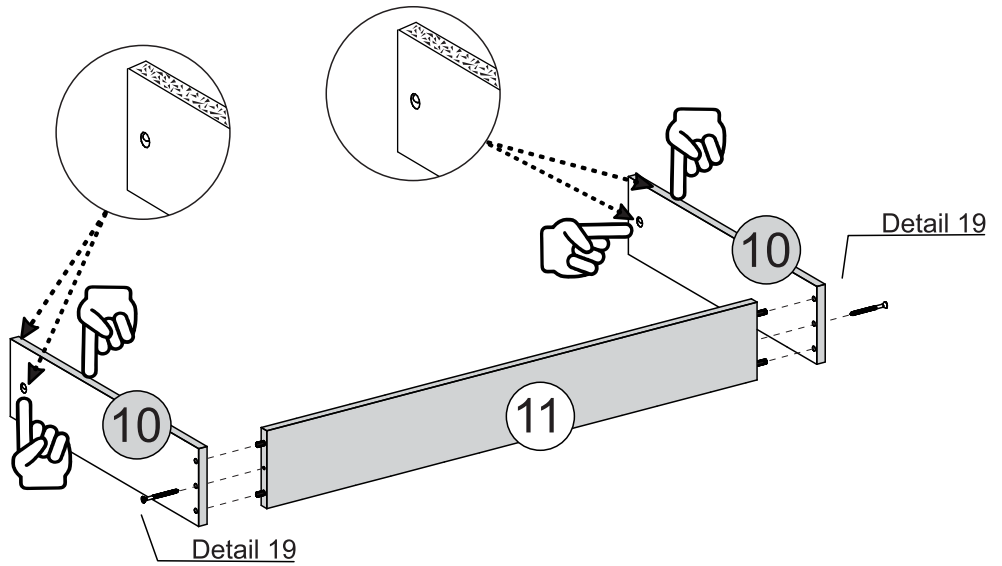
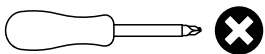

STEP 16

PARTS REQUIRED

12 - DRAWER FRONT x1

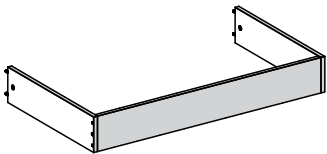

HARDWARE REQUIRED

A1  02

V  01

W  02

TOOLS REQUIRED

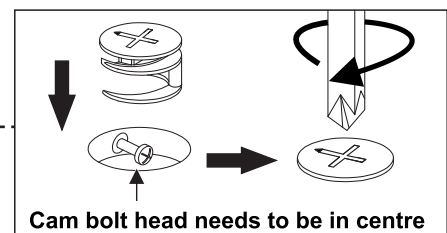
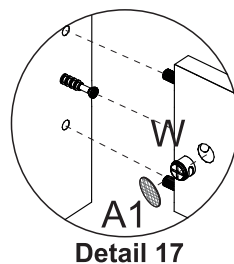
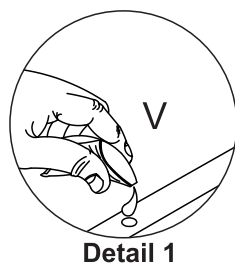
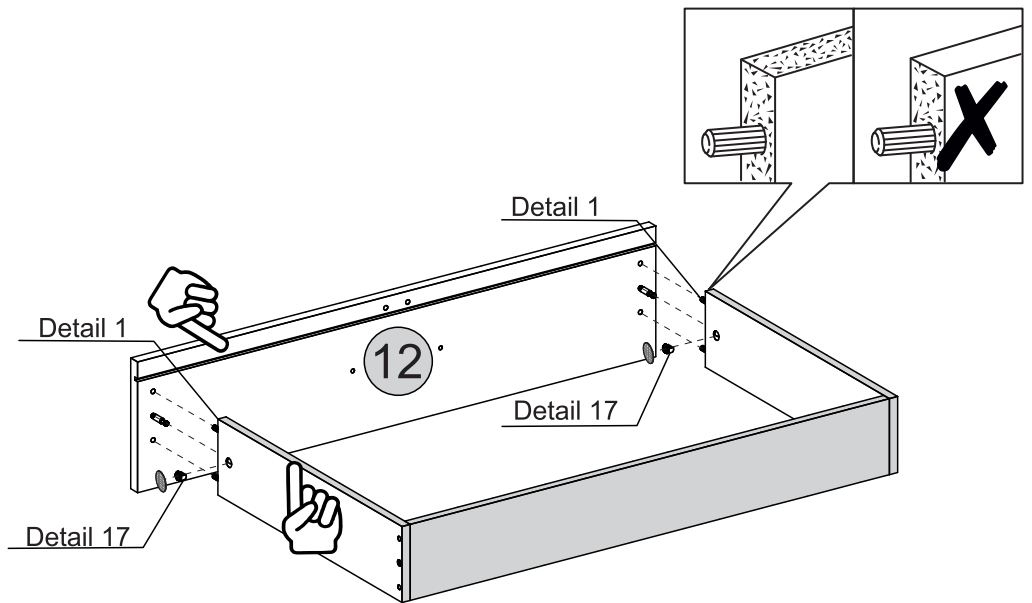
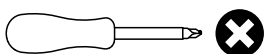

STEP 17

PARTS REQUIRED

13 - DRAWER BOTTOM x1

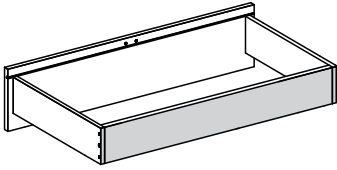

HARDWARE REQUIRED

H  04
10 x 10

TOOLS REQUIRED

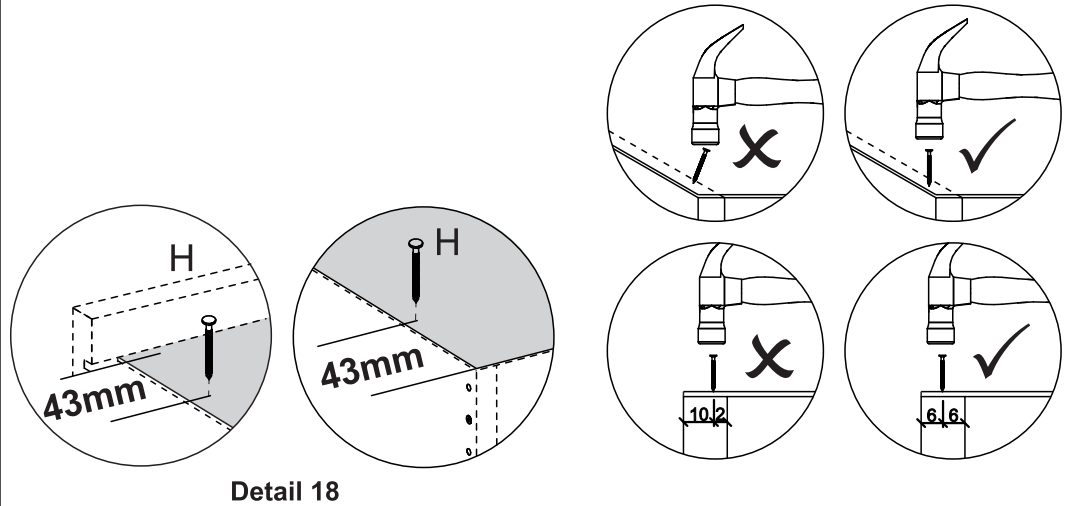
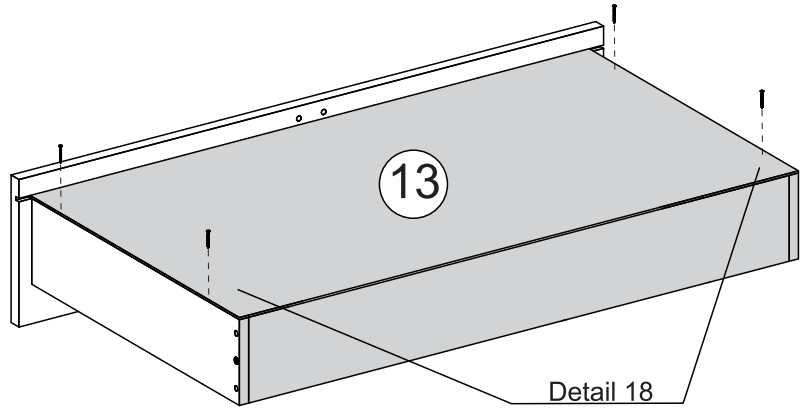
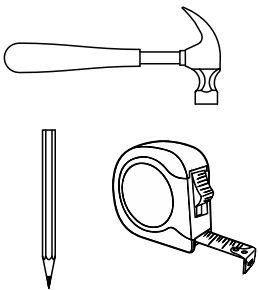

STEP 18

PARTS REQUIRED

14 - DRAWER BOTTOM SUPPORT BAR x1

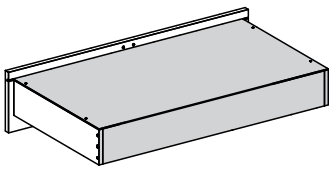

HARDWARE REQUIRED

H  06
10 x 10

TOOLS REQUIRED

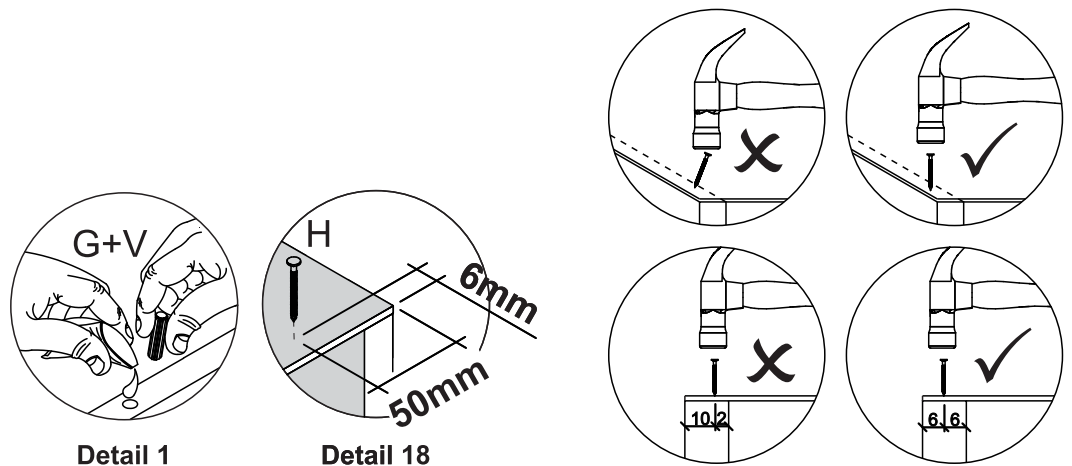
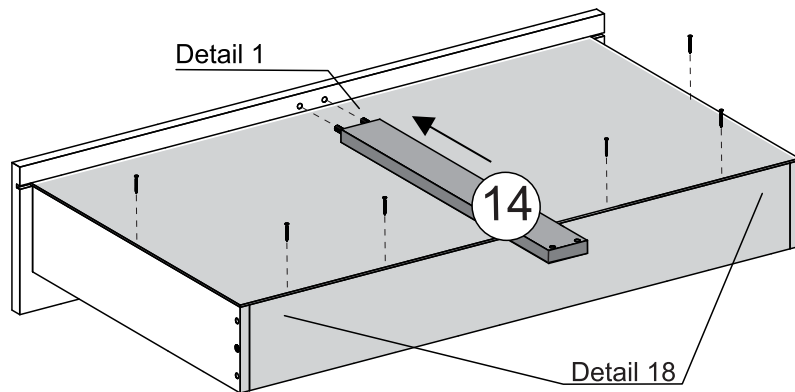
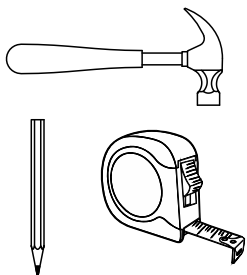

STEP 19

PARTS REQUIRED

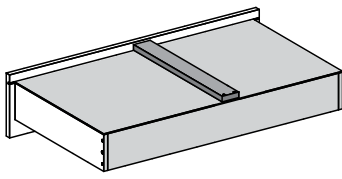

HARDWARE REQUIRED

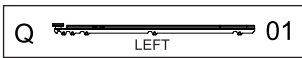
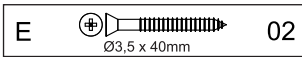

TOOLS REQUIRED

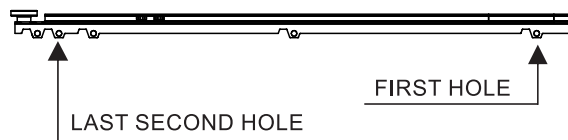
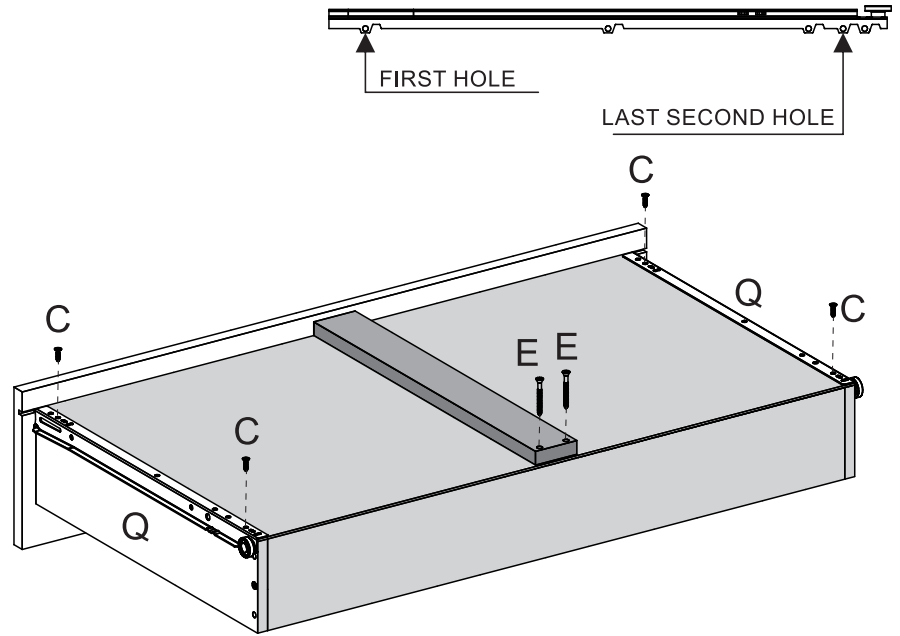
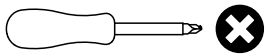

STEP 20

PARTS REQUIRED



HARDWARE REQUIRED

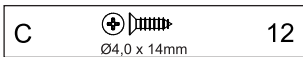

TOOLS REQUIRED

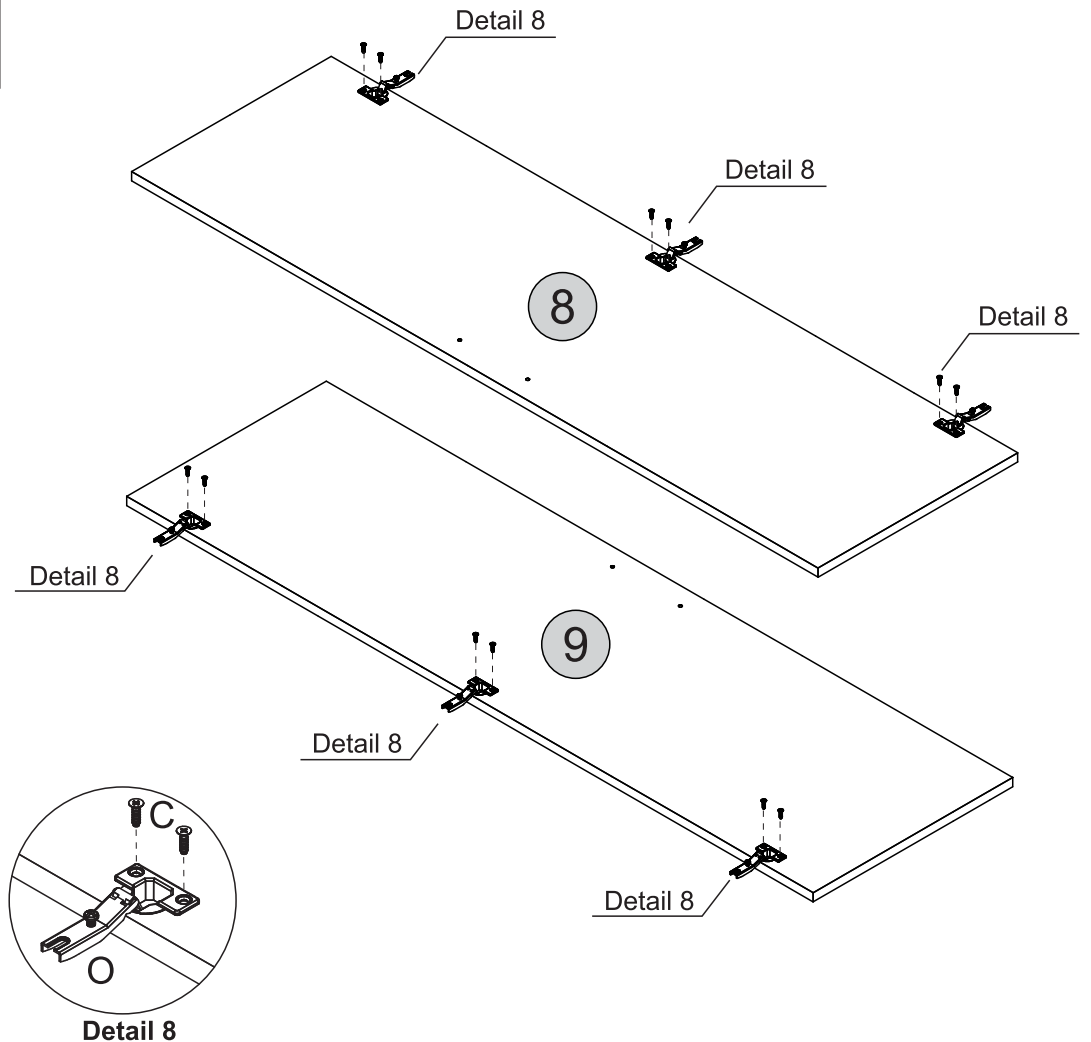
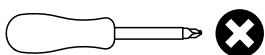

STEP 21

PARTS REQUIRED

8 - DOOR x1

9 - MIRRORED DOOR x1

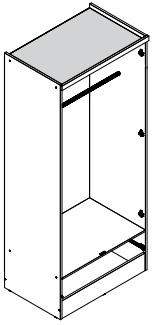

HARDWARE REQUIRED

U  12

TOOLS REQUIRED

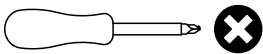

!
Please note the top or bottom edges of the doors are labelled LEFT or RIGHT to make them easier to identify when assembling.

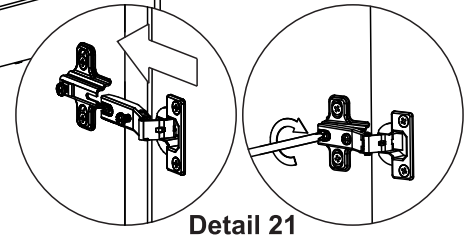
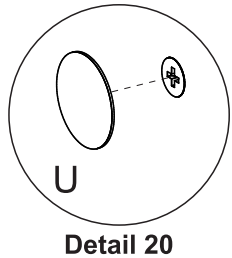
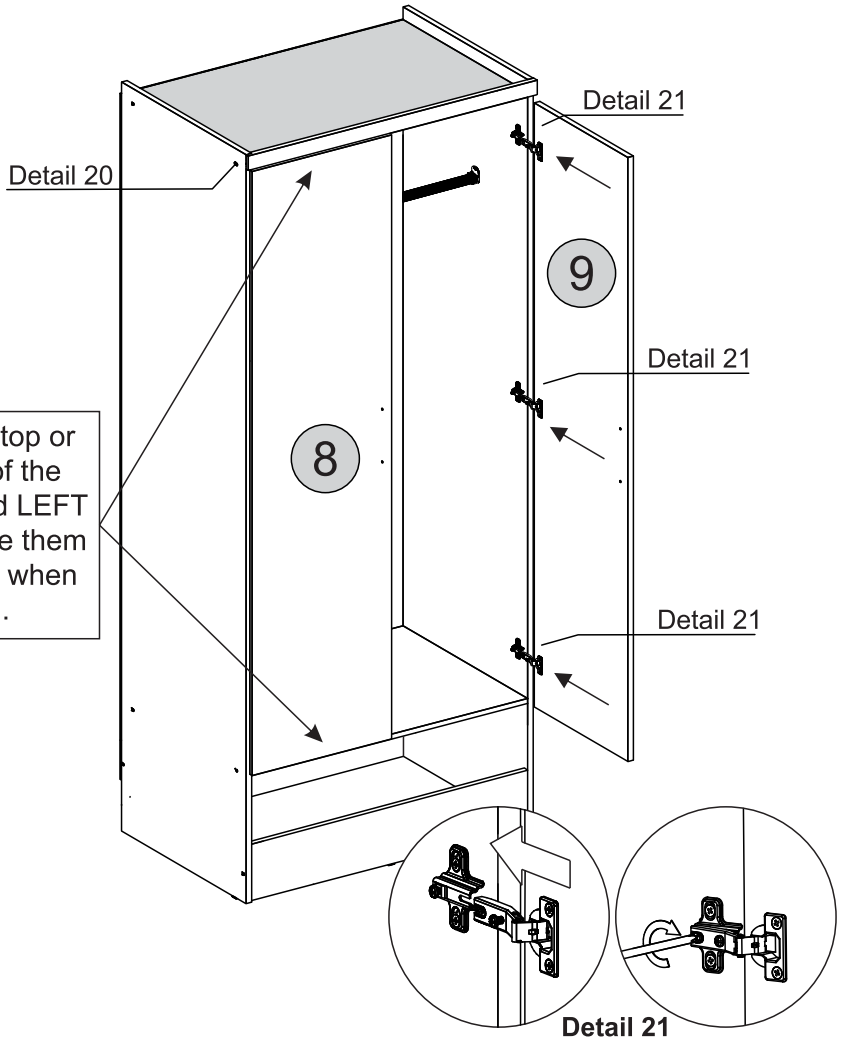

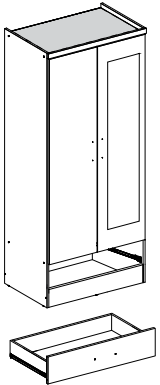

STEP 22

PARTS REQUIRED



HARDWARE REQUIRED

D  Ø4,0 x 20mm 06

T  03

TOOLS REQUIRED

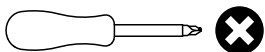

!
See the last page

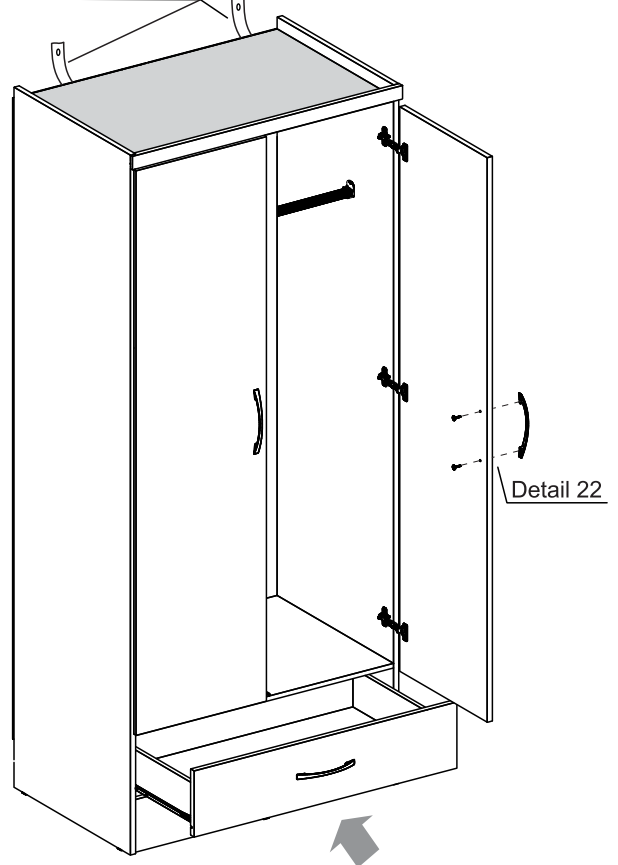
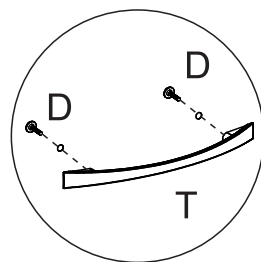
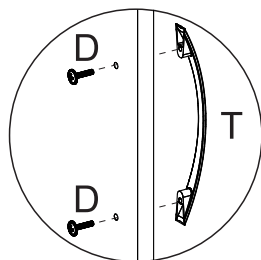

Detail 22

STEP 23

TIP
If desired, after assembly use an alcohol cleaner to erase the number printed on the parts.

PARTS REQUIRED

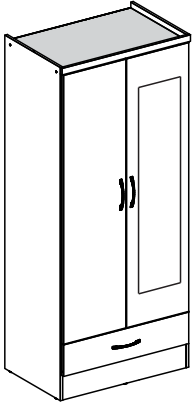

HARDWARE REQUIRED

C 02
Ø4.0 x 14mm

TOOLS REQUIRED

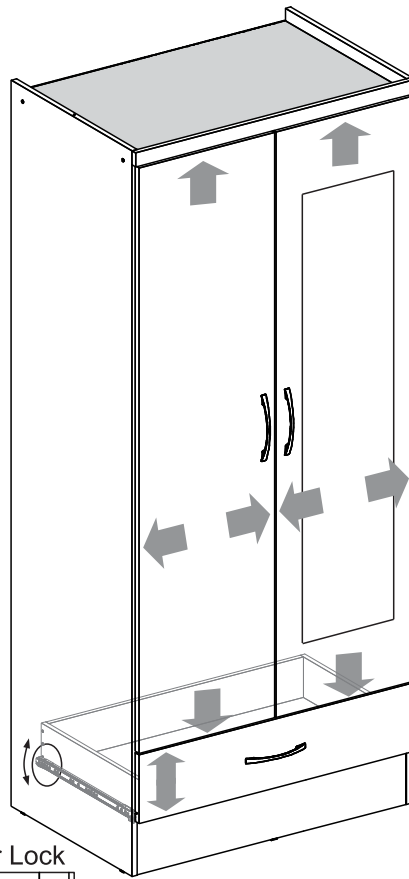
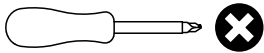

Height Adjustment

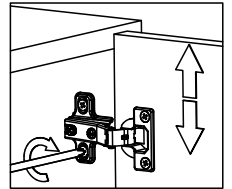

Internal Adjustment

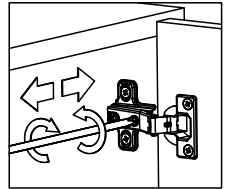

Depth Adjustment

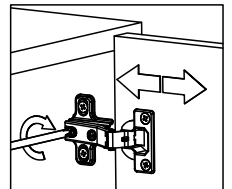
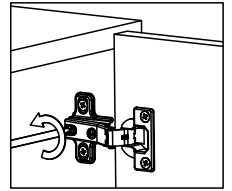

Drawer Adjustment **Drawer Lock**

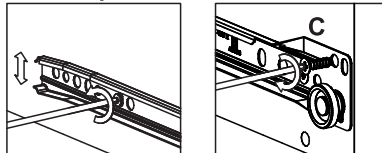

Detail 23

WARNING

Serious or fatal injuries can occur from furniture tipping over. To prevent the furniture from tipping over we recommend that it is permanently fixed to the wall.

Wall fixings are not supplied with this product as different wall materials require different types of fixing devices.

Please make sure you use fixings suitable for the walls in your home.

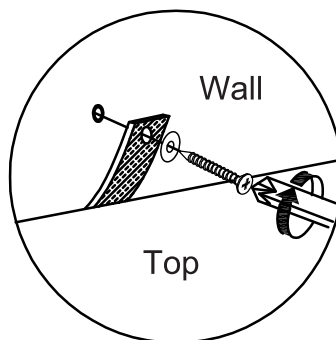
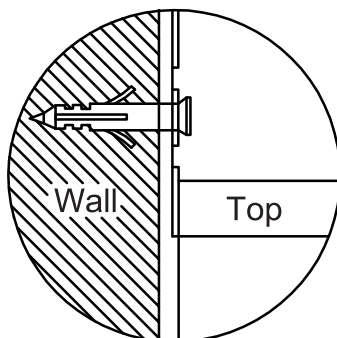
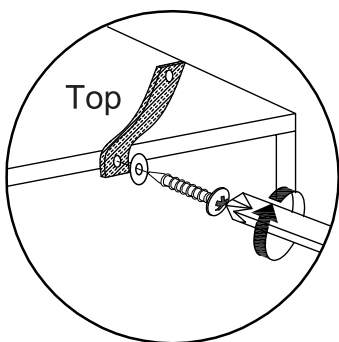

	I Flan Head Screw Ø3.5 x 30mm (2x)
	K Washer (4x)
	S Strap (2x)